

GAS INSULATED RING MAIN UNIT

alfa-R up to 36kV



safety...
durability



Contents

1 - Introduction to SF6 Free RMU Up to 24kV	7
A. SF6 Free RMU Solution	7
B. Environmental Impact of SF6	7
C. Dry Air Pressure	7
2- Operating Conditions and Standards	8
3 - SF6 Free RMU Drawing	9
4 - Technical Data Sheet	10
Technical Data Sheet LBS	11
Technical Data Sheet VCB	12
5 - Product Construction	13
SF6 Free RMU Drawing	13
Key Features	13
Safety	14
Standard Equipment	14
Optional Equipment	14
6 - alfa-R SF6 Free in Power Grid	15
7 - Applications	16

Conventional alfa-R 17.5kV

1 - Introduction to alfa-R 17.5kV	18
A. alfa-R Solution	18
B. Key Features	18
2 - Operating Conditions and Standards	19
3 - alfa-R Ranges and Dimensions	20
3.1 alfa-R -SBS -21kA Non Extensible Indoor	20
3.2 alfa-R -SBS -21kA Extensible Outdoor	20
3.3 alfa-R-SBBS-21kA Non-Extensible Outdoor	21
3.4 alfa-R-SBBS-21kA Non-Extensible Indoor	21
3.5 alfa-R -SSBS -21kA Non Extensible Indoor	22
3.6 alfa-R -SSBS -21kA Non Extensible Outdoor	22
3.7 alfa-R -B-21kA Extensible Outdoor Modular	23
3.8 alfa-R -S-21kA Extensible Outdoor Modular	23
4- Technical Data Sheet	24
Technical Data Sheet LBS	25
Technical Data Sheet VCB	26
5- Product Construction	27
Standard Equipment	27
Optional Equipment	27
For Extensible Type Compacts RMU's	27

6- Control Panels	28
7- MV Cables Connections	29
Conventional alfa-R 36kV	
1- Introduction to alfa-R 36kV	32
A. alfa-R Solution	32
B. Key Features	32
C. Safety	32
2- Operating Conditions and Standards	33
3- alfa-R Ranges and Dimensions	34
3.1 alfa-R -SBS -25kA Non Extensible Outdoor	34
3.2 alfa-R -SSBS -25kA Non Extensible Outdoor	35
3.3 alfa-R-SBBS -25kA Non Extensible Outdoor	36
3.4 alfa-R -B-25kA Extensible Outdoor Modular	37
3.5 alfa-R -S-25kA Extensible Outdoor Modular	37
4- Technical Data Sheet	38
Technical Data Sheet LBS	39
Technical Data Sheet VCB	40
5- Main Components	41
Standard Equipment	41
Optional Equipment	41
For Extensible Type Compacts RMU's	41
6- Control Panels	42
15.1 For Cubicle with Switch-Disconnecter	42
15.2 For Cubicle with Vacuum Circuit Breaker	42
7- MV Cables Connections	43
Smart RMU up to 36 kV	
1- Introduction to Smart RMU	45
A. Smart RMU	45
B. Key Features	45
2- Product Breakdown	46
3- Dimensional Drawings	47
3.1 Smart RMU 17.5 kV	47
SBS 3-Way Outdoor Type RMU	47
SBBS and SSBS 4-Way Outdoor Type RMU	47
3.2 Smart RMU 36 kV	48
SBS 3-Way Outdoor Type RMU	48
SBBS 4-Way Outdoor Type RMU	48
3.3 Smart RMU 36 kV	49
SSBS 4-Way Outdoor Type RMU	49
SSS 3-Way Outdoor Type RMU	49
3.4 Smart RMU 36 kV	50
SSSS 4-Way Outdoor Type RMU	50

4- Technical Data Sheet	51
4.1 Smart RMU 17.5kV.....	51
4.2 Smart RM 36kV.....	52
Compact RMU up to17.5 kV	
1- Introduction to Smart RMU	54
A. Smart RMU	54
B. Key Features	54
2- Dimensional Drawings	55
Compact RMU 17.5kV.....	55
3- Technical Data Sheet	56
4- Installation / Foundation View	57
5- Main Components	58
5.1 Switch-Disconnecter (with Earthing Switch).....	58
5.2 Vacuum Circuit Breaker + Disconnecter with Earthing Switch Unit.....	59
5.3 Gas Pressure Indicator.....	60
5.4 Voltage Presence Indication System.....	60
5.5 Protection Relay.....	61
6- Accessories	62
6.1 Operating Handles	62
6.2 IR / PD Windows.....	62
6.3 Motorization Kit.....	62
6.4 Earth Fault Indicator.....	63
6.5 Operation Counter for Load Breaker Switch Mechanism.....	63
6.6 CVI Auxiliary Contacts.....	63
6.7 Gas Pressure Indicator with Contacts.....	63
7- Control and Measuring Function	64
8- Smart alfa-R, Main Component	65
Notes	66

SF6-Free RMU Up to 24kV

1- Introduction to SF6 Free RMU Up to 24kV

A - SF6-Free RMU Solutions

Welcome to the future of medium voltage distribution with our environmentally-friendly and SF6-free Ring Main Unit (RMU). In a world increasingly focused on sustainability and reducing greenhouse gas emissions, our innovative RMU technology offers a solution that not only meets but exceeds environmental standards.

Say goodbye to the use of sulfur hexafluoride (SF6) gas, notorious for its high global warming potential, and embrace a cleaner, greener alternative without compromising on performance or reliability. Join us as we revolutionize medium voltage distribution, paving the way for a more sustainable and responsible energy future.

B- Environmental Impact of SF6

The environmental ramifications of sulfur hexafluoride (SF6) loom large on the horizon, primarily due to its exceptionally high Global Warming Potential (GWP) and its remarkable persistence in the atmosphere. SF6, though unparalleled in its effectiveness for energy transmission and distribution, possesses a GWP over 23,000 times greater than carbon dioxide over a 100-year period. This staggering metric underscores the potent contribution of SF6 to the greenhouse effect, amplifying the impact of anthropogenic activities on climate change.

Moreover, SF6 has a lengthy atmospheric lifespan, lasting for centuries once released. The traditional reliance on SF6 in energy infrastructure, while ensuring efficient electricity delivery, has consequently become a source of environmental apprehension. The release of SF6 during maintenance, accidents, or at the end of a product's life cycle contributes significantly to the accumulation of greenhouse gases in the atmosphere. This poses a dual challenge—ensuring reliable energy transmission while mitigating the environmental toll of SF6.

Urgency permeates this discourse, prompting a critical reevaluation of our energy infrastructure practices and the imperative to find viable alternatives. As the environmental clock ticks, the quest for SF6-free technologies gains significance, offering a pathway to align the energy sector with sustainable practices and mitigate the pressing environmental concerns associated with SF6 usage.

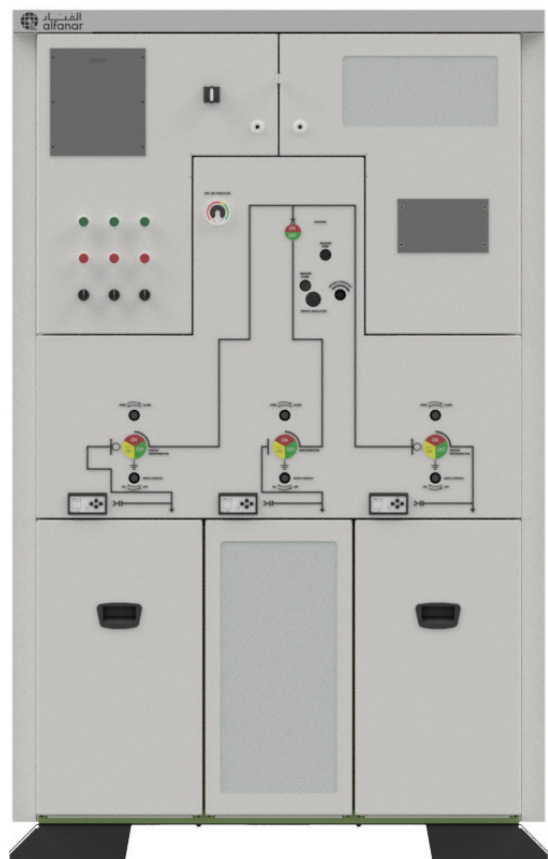

C- Dry Air Pressure

Due to the state-of-the-art technology by alfanar R&D teams, it was possible to achieve the design without changing the pressure comparing to the standard SF6 product.

Therefore, alfanar can proudly confirm that dry air pressure inside the tank is no more than 1.3 bar absolute, which puts alfanar in a leading position among all similar technology owners.

Keeping the pressure at such a lower limit improves and ensures the safety of equipment during transportation and installation as well as minimizing the risk of leakage.

2- Operating Conditions and Standards

- alfa-R has an embedded hermetically sealed gas tank filled with dry air having a rated pressure of 1.3 bar, abs. and a minimum operating pressure of 1.05 bar, abs.
- The expected lifetime of the product is more than 40 years with a leakage rate of less than 0.1 % per year.
- No maintenance or gas refilling is required during the lifetime of the alfa-R.
- The main busbar and switching compartment has an IP 67 protection degree rating whereas the other sections of indoor products are rated at IP 41 and the outdoor products are rated IP 54.

Operating conditions:

- Ambient temperature range from -25 °C to 55 °C
- Altitude range of (0-2500 m)*
- Maximum relative humidity of 100%



alfa-R fully complies with the following IEC Standards used under general operating conditions.

	STANDARDS	CLASSIFICATION	
		Partition	PM
alfa-R	IEC 62271-200	Loss of Service Contuinity	LSC 2
		Internal arc	A (FLR) 21 kA-1 s
		General purpose, M2, E3	
SWITCH-DISCONNECTOR	IEC 62271-103	General purpose, M2, E3	
CIRCUIT BREAKER	IEC 62271-100	M2, E2 (for cable network)	
DISCONNECTOR	IEC 62271-102	M1, E0	
EARTHING SWITCH	IEC 62271-102	E2	
VOLTAGE DETECTION SYSTEM	IEC 61243-5	Voltage Presence Indicating System (VPIS)	
CABLE BUSHING	IEC 50181	Outer cone plug-in bushing with interface type C	

3- SF6 Free RMU Drawing

Indoor

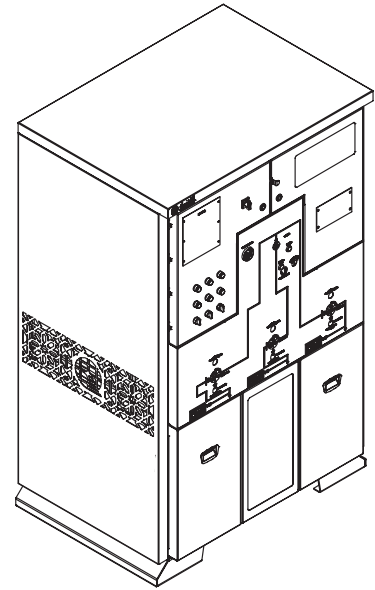
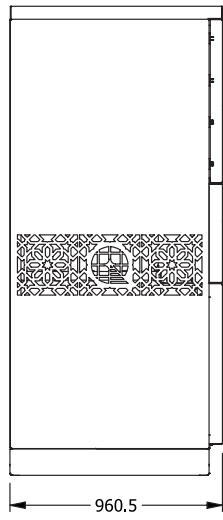
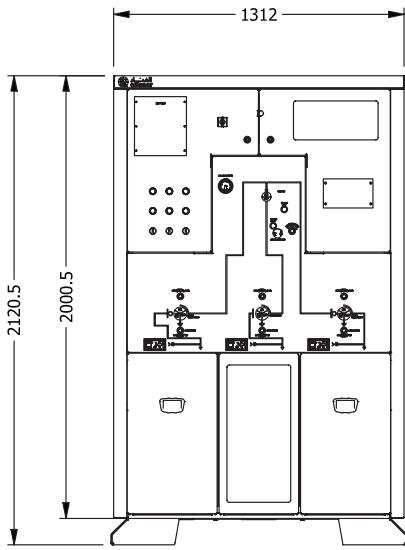

Outdoor

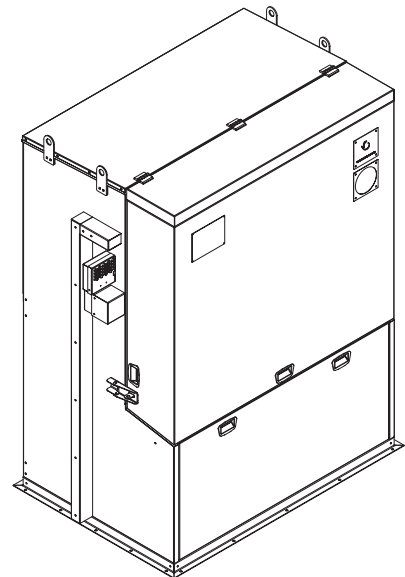
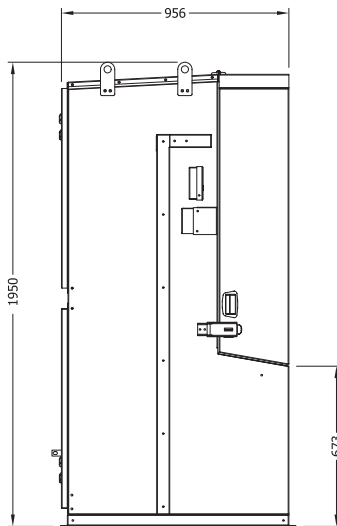
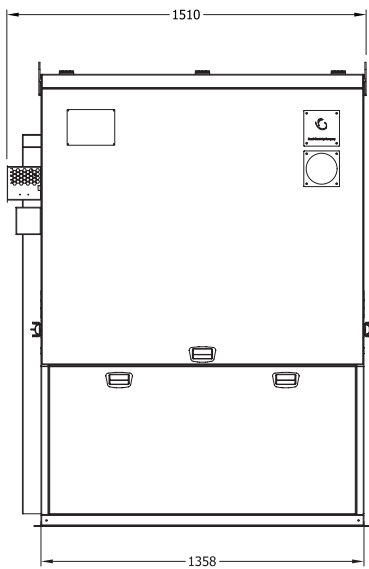

4- Technical Data Sheet

Electrical Characteristics	
Manufacturer	alfanar Electrical Systems
Type	alfa-R
Voltage (Ur)	24 kV
Insulation level	
- power frequency withstand voltage (Ud) – common value	50 kVrms
- power frequency withstand voltage (Ud) – across the isolating distance	60 kVrms
- lightning impulse withstand voltage (Up) – common value	125 kVpeak
- lightning impulse withstand voltage (Up) – across the isolating distance	145 kVpeak
Frequency (fr)	50/60 Hz
Normal current (Ir)	630 A
Short-time withstand current for main (Ik) and earthing circuits (Ike)	21 kA
Peak withstand current for main (Ip) and earthing circuits (Ipe)	54.6 kA
Duration of short circuit (tk – tke)	1 s
Internal arc classification (IAC) (type of accessibility and classified sides)	AFLR
Arc fault current (IA)	21 kA
Arc fault duration (tA)	1 s
Partition class	PM
Loss of service continuity category	LSC 2
Degree of protection	IP54 / IP41
Type of application	indoor/outdoor
Rated supply voltage of auxiliary and control circuits (Ua)	DC 24 V
Type of neutral earthing	Solidly earthed neutral

Technical Data Sheet

Load Break Switch

Electrical Characteristics	
Manufacturer	alfanar Electrical Systems
Type	alfa-L
Voltage (Ur)	24 kV
Insulation level	
- power frequency withstand voltage (Ud) – common value	50 kVrms
- rated impulse withstand voltage	125 kVrms
Main active load breaking current	630A
Closed loop breaking current	630A
Cable charging breaking current	16.7A
Short-time withstand current for main (Ik) and earthing circuits (Ike)	21 kA
Peak withstand current for main (Ip) and earthing circuits (Ipe)	54.6 kA
Duration of short circuit (tk – tke)	1 s
Mechanical endurance	M2
Electrical endurance	E3
Weight	70 Kg
Short circuit duration	1 s
Earth fault breaking current	50.6A
Operating mechanism	alfa-L
Closing device	24 VDC
Opening device	24 VDC
Motor	24 VDC

Technical Data Sheet

Vacuum Circuit Breaker

Electrical Characteristics	
Manufacturer	alfanar Electrical Systems
Type	alfa-V
Voltage (Ur)	24 kV
Insulation level	
- power frequency withstand voltage (Ud) – common value	50 kVrms
- rated impulse withstand voltage	125 kVrms
DC component (referred to time constant = 45 ms)	55%
Minimum opening time	20 ms
Frequency (fr)	50/60 Hz
Normal current (Ir)	630 A
Short-time withstand current for main (Ik) and earthing circuits (Ike)	21 kA
Peak withstand current for main (Ip) and earthing circuits (Ipe)	54.6 kA
Duration of short circuit (tk – tke)	1 s
Mechanical endurance	M2
Electrical endurance	E2
Weight	90 kg
Rated operating sequence	O 0.3s - CO - 3min - CO
Applied standard	IEC 62271-100
Operating mechanism	alfa-V
Closing device	24 VDC
Opening device	24 VDC
Motor	24 VDC

5- Product Construction

SF6 Free RMU Drawing

Indoor

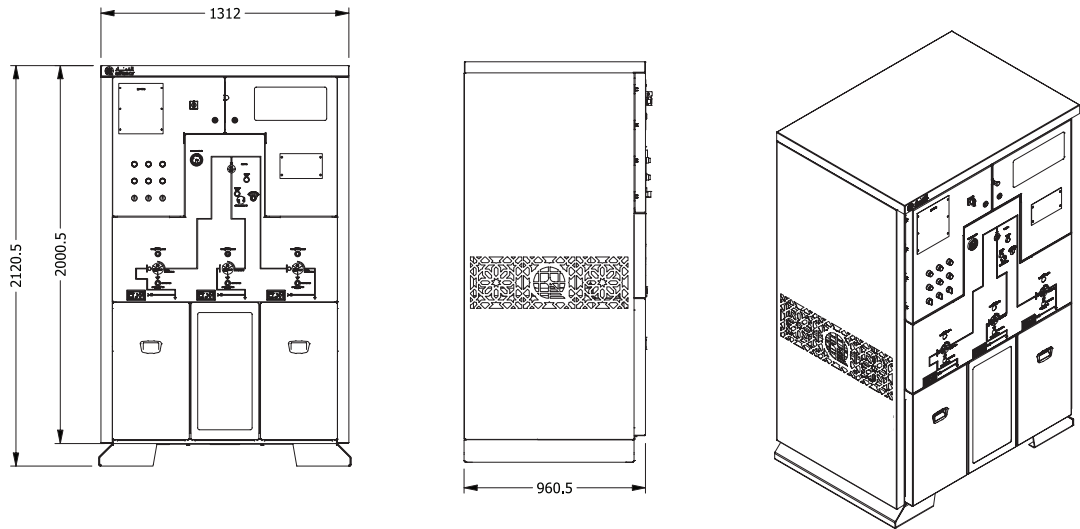

Outdoor

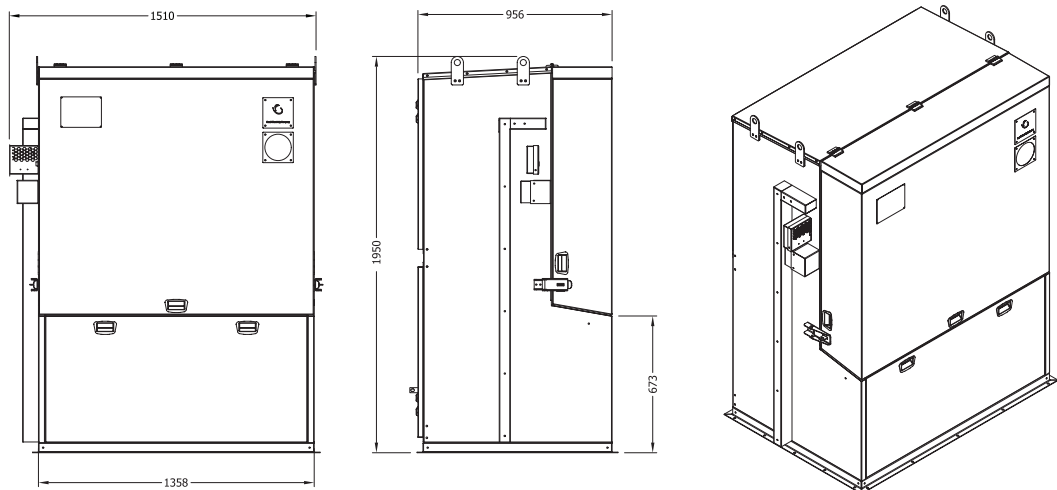

Key features

- Identical size to SF6 insulated RMUs.
- High-level operator safety, high-level operational reliability (The RMU can be fully operated without a single drop of dry air inside).
- Identical dry-air filling pressure to SF6 gas pressure.
- Hermetically sealed pressure system, leakage rate less than % 0.1 per year.
- Resistant to pollution, insensitive to humidity and altitude.
- Modular and compact type (extensible and non-extensible).
- Lower maintenance cost.
- Suitable for remote control and monitoring.
- Comply with relevant IEC and EN standards.
- RMU's can be manufactured to be extensible for either both sides or for only the left/right side.

Safety

- The durable design withstands internal arc, providing protection against thermal and dynamic effects
- Consecutive interlocking systems prevent incorrect operation
- Access to the cable compartment is only possible if the related Earthing Switch/Switches are in the earthed position
- Considering the lack of SF6 gas, the product is environmentally friendly and there is no harm in case of the occurrence of short circuit

Standard Equipment

1. Feeders with Switch-disconnector

- Switch-disconnector (three-positioned, open-closed-earthed)
- Integrated capacitive Voltage Presence Indicator System
- Operating mechanism
- Interface C bushings

2. PC Feeder with Vacuum Circuit Breaker

- Vacuum circuit breaker
- Disconnecter with earthing switch
- Over current and earth fault relay
- Current transformer
- Integrated capacitive Voltage Presence Indicator System
- Operating mechanism
- Interface C bushings

3. Dry Air Pressure Manometer

4. Main Busbar, Earthing Bar

5. Operating Handle

6. Pad-locking facility

Optional Equipment

- Dry Air Pressure Manometer (hermetic and double contact)
- Remote OPENING and CLOSING operation with cable
- Motor + Gear Box

6- alfa-R SF6 Free in Power Grid

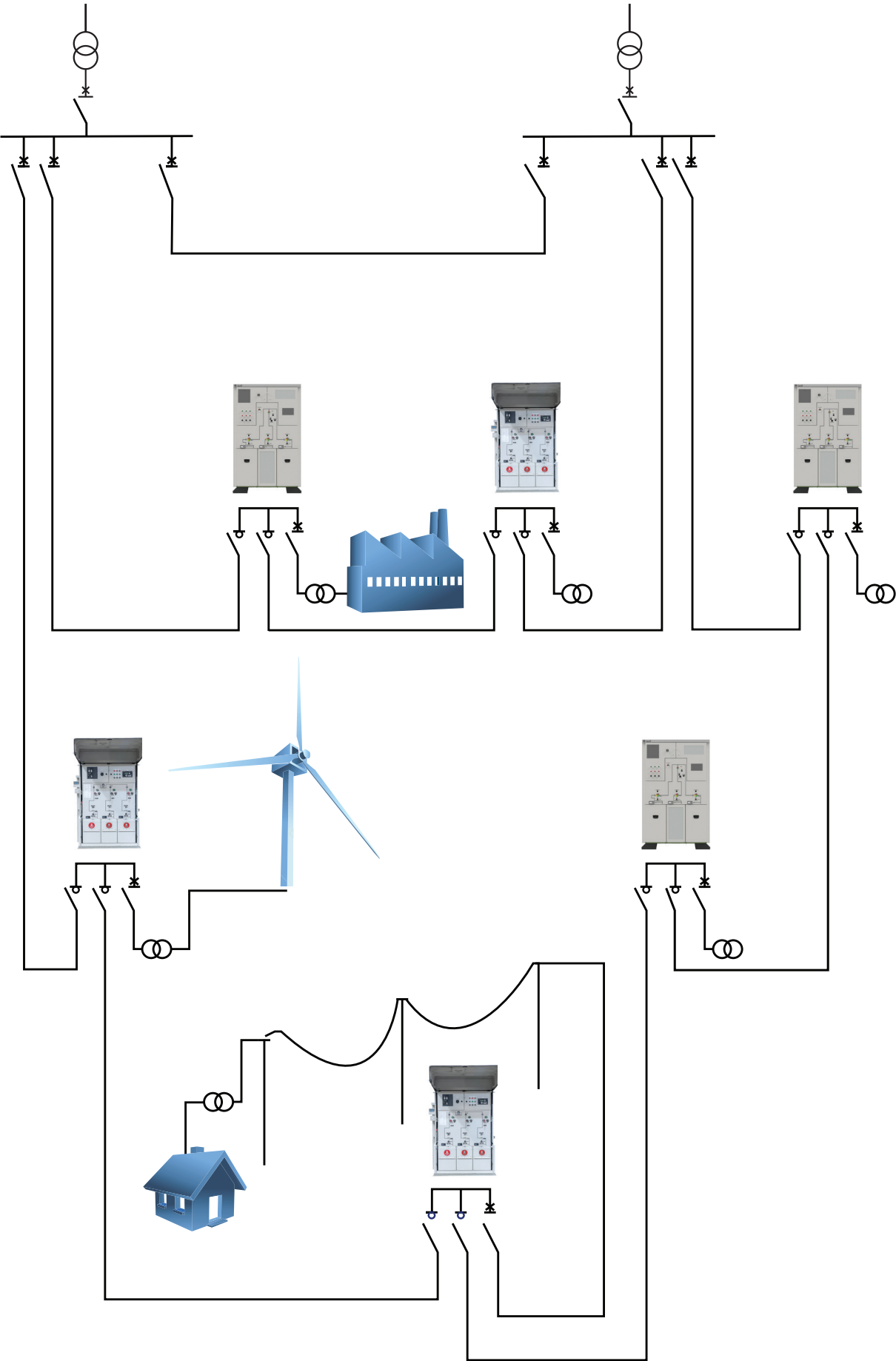

7- Applications

alfa-R units are widely used in the following applications:



A - Infrastructure and buildings: ports, railway stations, airports, hospitals, schools, hotels, malls, commercial centers, holiday resorts, etc.



B - Industries: water, iron and steel, automotive, oil and gas, etc.

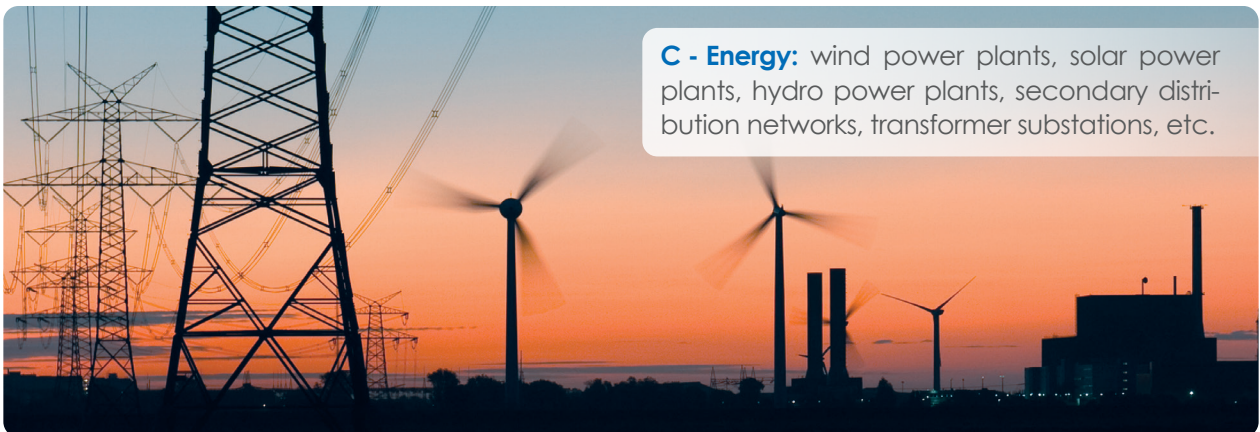

C - Energy: wind power plants, solar power plants, hydro power plants, secondary distribution networks, transformer substations, etc.



D - Special applications: high air pollution areas, high humidity areas, etc.

CONVENTIONAL alfa-R 17.5 kV

1- Introduction to alfa-R 17.5 kV

A - alfa-R Solution

alfa-R units are designed to supply reliable energy and protect electrical equipment in secondary distribution networks up to 36 kV. alfa-R units are the best solution for indoor/outdoor distribution substations as their compact design makes them suitable for various network applications such as transformer substations, wind power plants, industrial zones, etc.

B. Key Features

- Compact design and type tested.
- High-level operator safety, high-level operational reliability.
- Lower filling SF6 gas pressure and lower minimum operating SF6 gas pressure.
- Hermetically sealed pressure system, leakage rate less than % 0.1 per year.
- Resistant to pollution, insensitive to humidity and altitude.
- Modular and compact type (extensible and non-extensible).
- Lower maintenance cost.
- Suitable for remote control and monitoring.
- Comply with relevant IEC and EN standards.
- Compact type RMU's can be manufactured to be extensible for either both sides or for only the left/right side.



2- Operating Conditions and Standards

- alfa-R has an embedded hermetically-sealed gas tank filled with SF6 gas having a lower filling SF6 gas pressure (1,1 bar, abs.) and lower minimum operating SF6 gas pressure (1,05 bar, abs.).
- The expected lifetime of the product is more than 30 years with a leakage rate of less than 0.1 % per year.
- No maintenance or gas refilling is required during the lifetime of the alfa-R.
- The main busbar and switching compartment has an IP 67 protection degree rating whereas the other sections of indoor products are rated at IP 41 and the outdoor products are rated IP 54.

Operating conditions:

- Ambient temperature range from -25 °C to 55 °C
- Altitude range of (0-1000 m)*
- Maximum relative humidity of 100%



alfa-R fully complies with the following IEC Standards used under general operating conditions.

	STANDARDS	CLASSIFICATION	
		Partition	PM
alfa-R 36	IEC 62271-200	Loss of Service Contuinity	LSC 2
		Internal arc	A (FLR) 21 kA-1 s
		General purpose, M2, E3	
SWITCH-DISCONNECTOR	IEC 62271-103	General purpose, M2, E3	
CIRCUIT BREAKER	IEC 62271-100	M2, E2 (for cable network)	
DISCONNECTOR	IEC 62271-102	M1, E0	
EARTHING SWITCH	IEC 62271-102	E2	
VOLTAGE DETECTION SYSTEM	IEC 61243-5	Voltage Presence Indicating System (VPIS)	
PLUG-IN BUSHINGS	IEC 50181	Outer cone plug-in bushing	

*: For 1000+ m please contact [alfanar](#)

3- alfa-R Ranges and Dimensions

3.1 alfa-R-SBS-21KA(NON-EXTENSIBLE INDOOR)

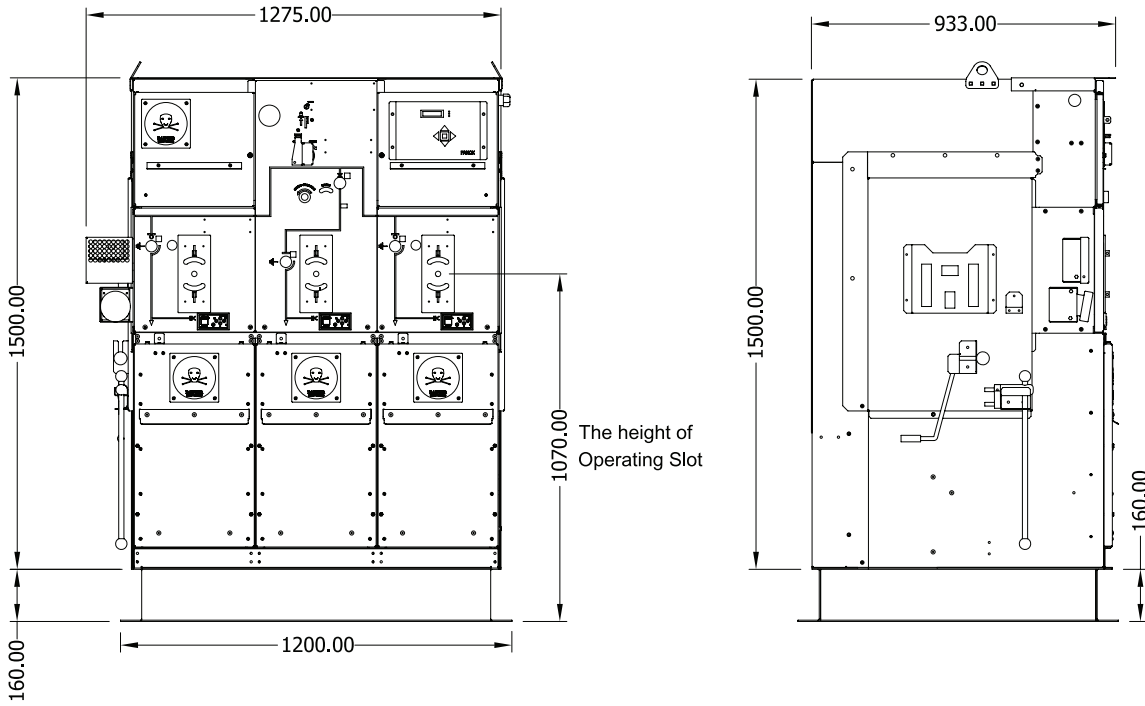

3.2 alfa-R-SBS-21KA (NON-EXTENSIBLE OUTDOOR)

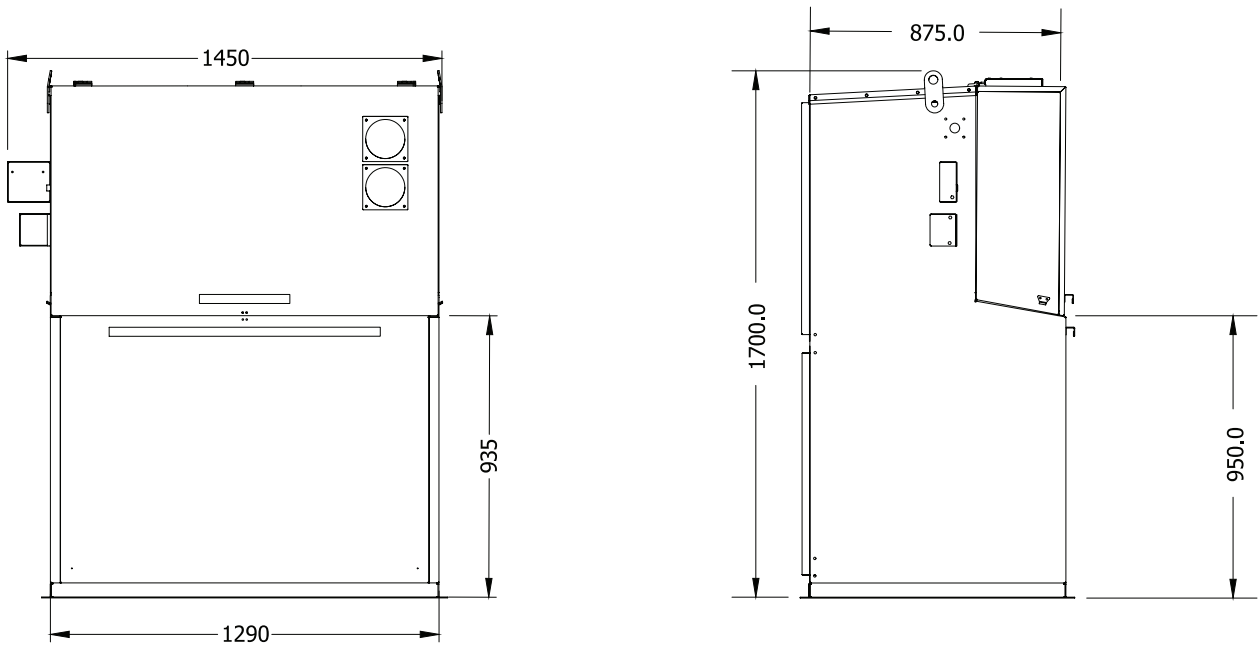

3.3 alfa-R-SBBS-21kA Non-Extendible Outdoor

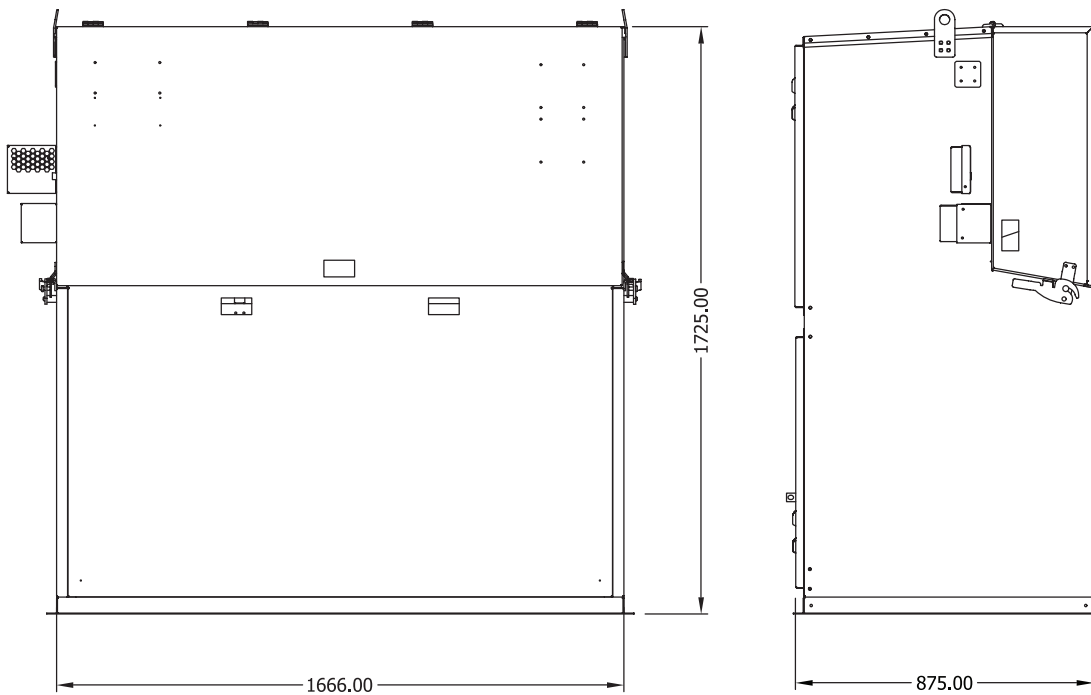

3.4 alfa-R-SBBS-21kA Non-Extendible indoor

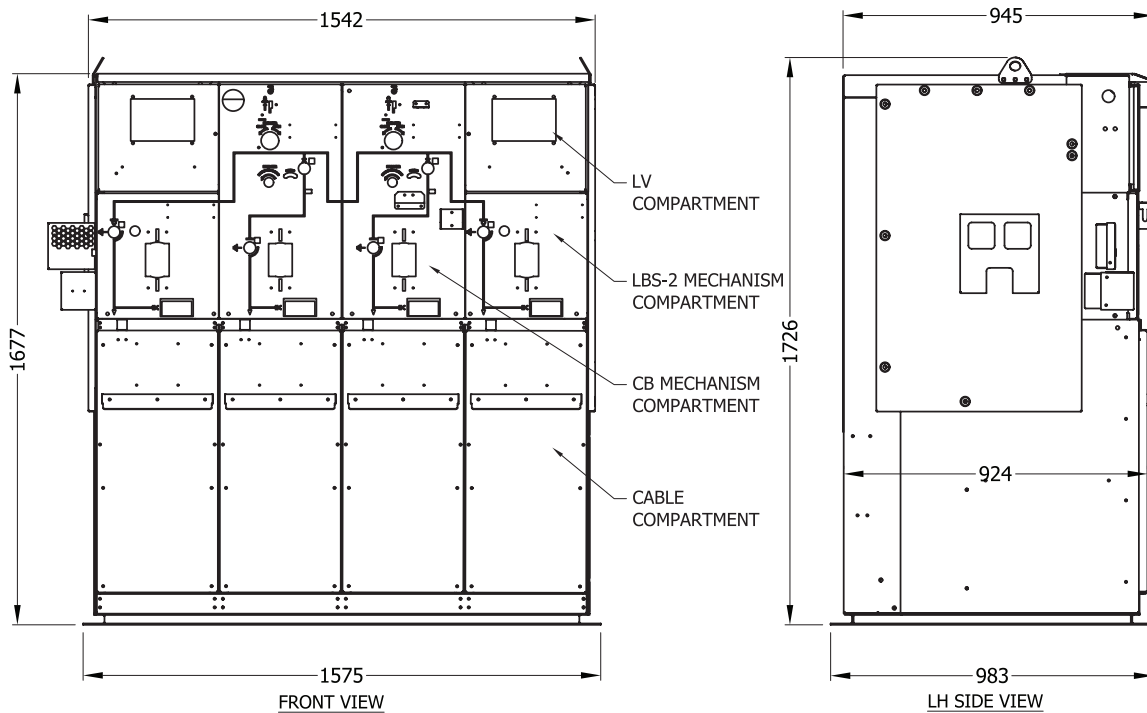

3.5 alfa-R-SSBS-21kA (NON-EXTENSIBLE INDOOR)

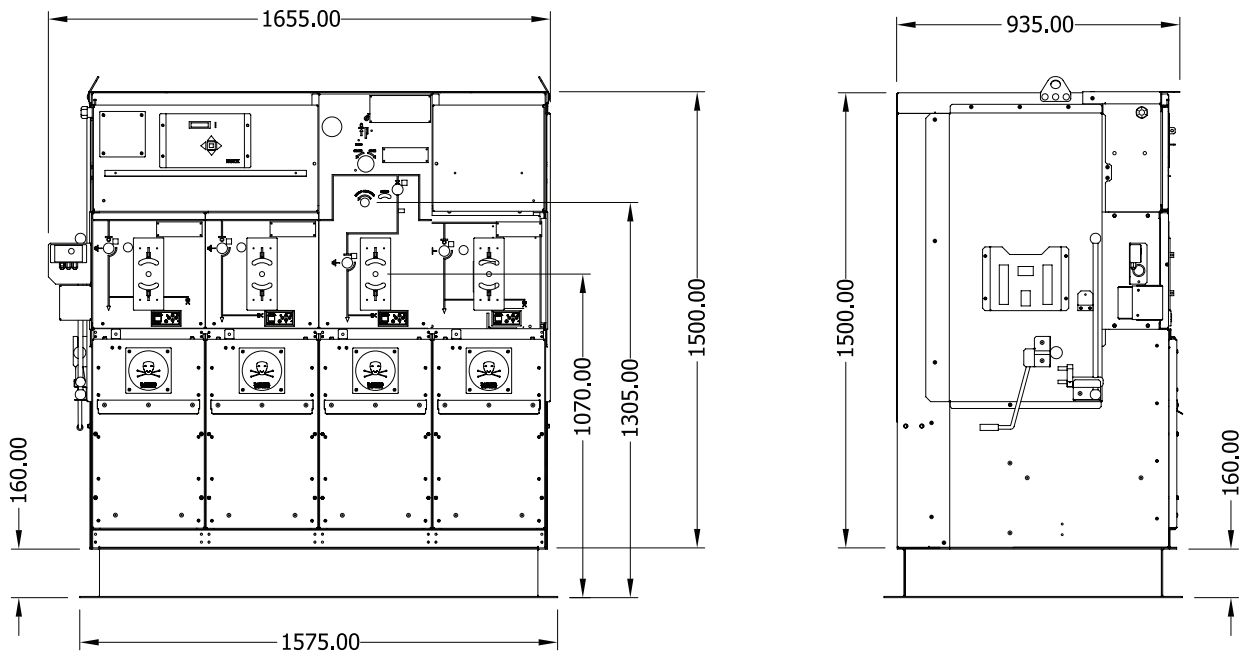

3.6 alfa-R-SSBS-21kA (NON-EXTENSIBLE OUTDOOR)

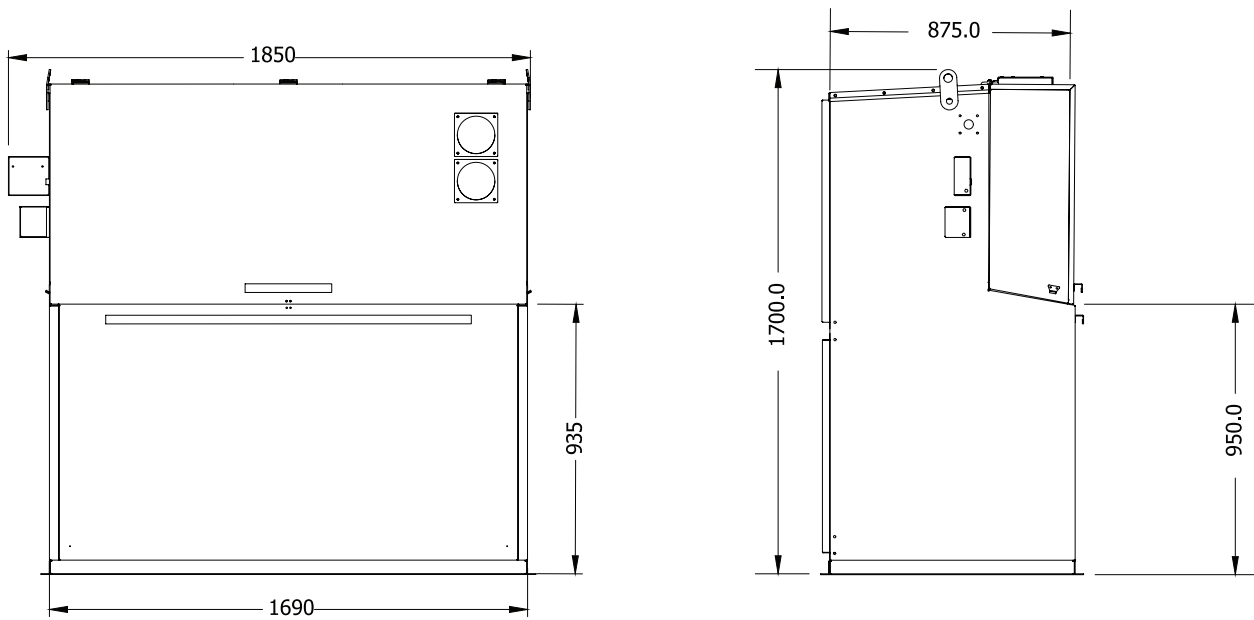

3.7 alfa-R-B-21KA (EXTENSIBLE OUTDOOR) - Modular

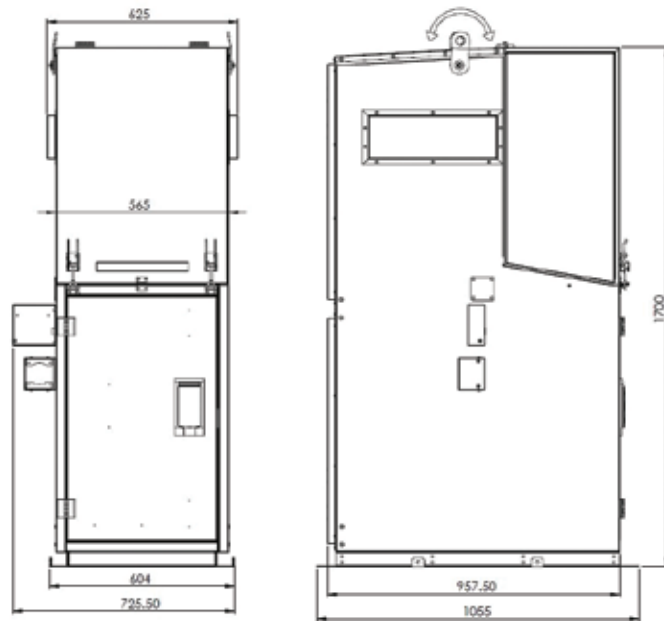

3.8 alfa-R-S-21KA (EXTENSIBLE OUTDOOR) - Modular

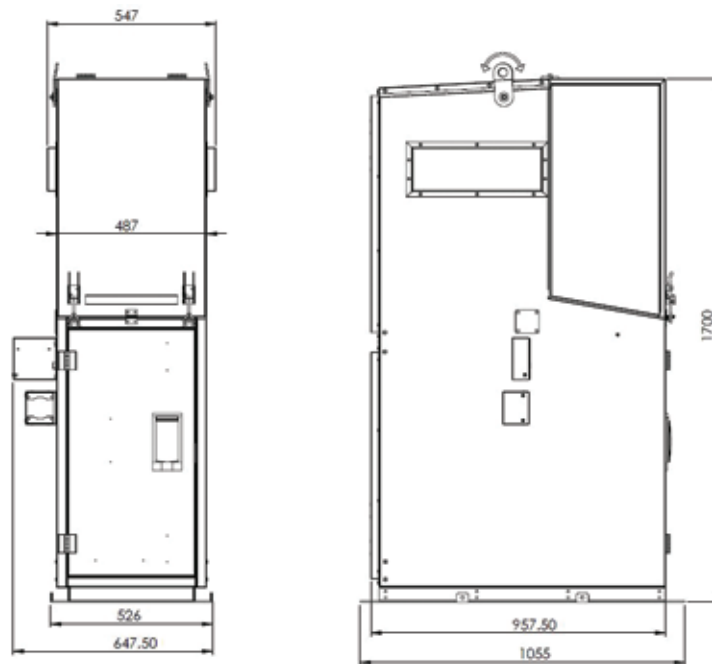

4- Technical Data Sheet

Electrical Characteristics	
Manufacturer	alfanar Electrical Systems
Type	alfa-R
Voltage (Ur)	17.5 kV
Insulation level	
- power frequency withstand voltage (Ud) – common value	38 kVrms
- power frequency withstand voltage (Ud) – across the isolating distance	45 kVrms
- lightning impulse withstand voltage (Up) – common value	95 kVpeak
- lightning impulse withstand voltage (Up) – across the isolating distance	110 kVpeak
Frequency (fr)	50/60 Hz
Normal current (Ir)	630 A
Short-time withstand current for main (Ik) and earthing circuits (Ike)	21 kA
Peak withstand current for main (Ip) and earthing circuits (Ipe)	54.6 kA
Duration of short circuit (tk – tke)	1 s
Internal arc classification (IAC) (type of accessibility and classified sides)	AFLR
Arc fault current (IA)	21 kA
Arc fault duration (tA)	1 s
Partition class	PM
Loss of service continuity category	LSC 2
Degree of protection	IP54 / IP41
Type of application	indoor/outdoor
Rated supply voltage of auxiliary and control circuits (Ua)	DC 24 V
Type of neutral earthing	Solidly earthed neutral

Technical Data Sheet

Load Break Switch

Electrical Characteristics	
Manufacturer	alfanar Electrical Systems
Type	alfa-L
Voltage (Ur)	17.5 kV
Insulation level	
- power frequency withstand voltage (Ud) – common value	38 kVrms
- rated impulse withstand voltage	95 kVrms
Main active load breaking current	630A
Closed loop breaking current	630A
Cable charging breaking current	10A
Short-time withstand current for main (Ik) and earthing circuits (Ike)	21 kA
Peak withstand current for main (Ip) and earthing circuits (Ipe)	54.6 kA
Duration of short circuit (tk – tke)	1 s
Mechanical endurance	M2
Electrical endurance	E3
Weight	70 Kg
Short circuit duration	1 s
Earth fault breaking current	30A
Operating mechanism	alfa-L
Closing device	24 VDC
Opening device	24 VDC
Motor	24 VDC

Technical Data Sheet

Vacuum Circuit Breaker

Electrical Characteristics	
Manufacturer	alfanar Electrical Systems
Type	alfa-V
Voltage (Ur)	17.5 kV
Insulation level	
- power frequency withstand voltage (Ud) – common value	38 kVrms
- rated impulse withstand voltage	95 kVrms
DC component (referred to time constant = 45 ms)	55%
Minimum opening time	33 ms
Frequency (fr)	50/60 Hz
Normal current (Ir)	630 A
Short-time withstand current for main (Ik) and earthing circuits (Ike)	21 kA
Peak withstand current for main (Ip) and earthing circuits (Ipe)	65 kA
Duration of short-circuit (tk – tke)	1 s
Mechanical endurance	M1
Electrical endurance	E2
Weight	90 kg
Rated operating sequence	O-0.3-CO3min-Co
Applied standard	IEC 62271-100
Operating mechanism	alfa-V
Closing device	24 VDC
Opening device	24 VDC
Motor	24 VDC

5- Product Construction

Compact alfa-R units are an excellent solution for secondary distribution networks. The units cover all medium voltage functions such as connection, supply and protection of MV equipment for different applications.

Standard Equipment

- **Two Feeders with Switch-Disconnecter:**
 - Switch-disconnector (three-positioned, open-closed-earthed)
 - Integrated capacitive Voltage Presence Indicator System.
 - Operating mechanism
 - Interface C bushings
- **One / Two pc Feeder with Vacuum Circuit Breaker:**
 - Vacuum circuit breaker
 - Disconnector with earthing switch
 - Over current and earth fault relay
 - Current transformer
 - Integrated capacitive Voltage Presence Indicator System
 - Operating mechanism
 - Interface C bushings
- **SF6 Gas Pressure Manometer**
- **Main Busbar, Earthing Bar**
- **Operating Handle**
- **Pad-locking facility**



Optional Equipment

- SF6 Gas Pressure Manometer (hermetic and double contact)
- Remote OPENING and CLOSING operation with cable
- Motor + Gear Box

For Extensible Type Compacts RMU's

- Extension Boots
- Extension Bar
- Screened Plug

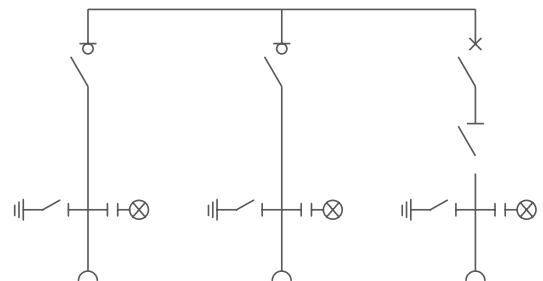

6- Control Panels



1. Self powered protection relay
2. Gas level indicator
3. Pad-lock
4. Circuit breaker operation (motor optional)
5. Position indicator for circuit breaker
6. Operation counter
7. Position indicator for switch disconnector
8. Cable test facility lock
9. Switch-disconnector operation (motor optional)
10. Shutter padlock facility
11. Voltage presence indicator

7- MV Cables Connections

The floor must be well leveled and the unit must be fixed with anchor bolts in accordance with the dimensional drawing for the number of modules or units as appropriate.

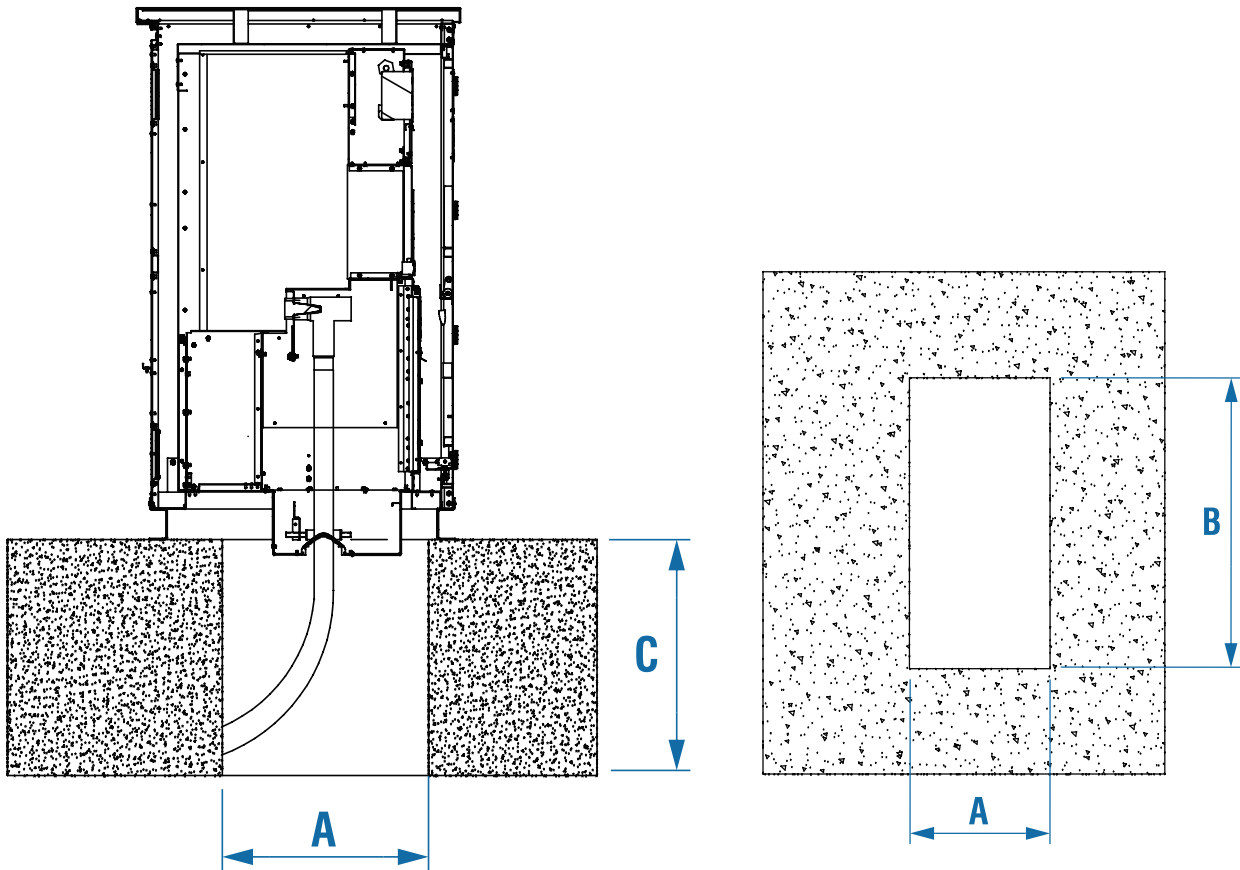

RMU Type	A mm	B mm	C mm
SBS 3-way Indoor	700	1060	1200
SBS 3-way Outdoor	630	1140	1200
SBBS / SSBS 4-way Indoor	700	1435	1200
SBBS / SSBS 4-way Outdoor	630	1510	1200

The ground where the equipment will be fixed should be prepared in the following manner:

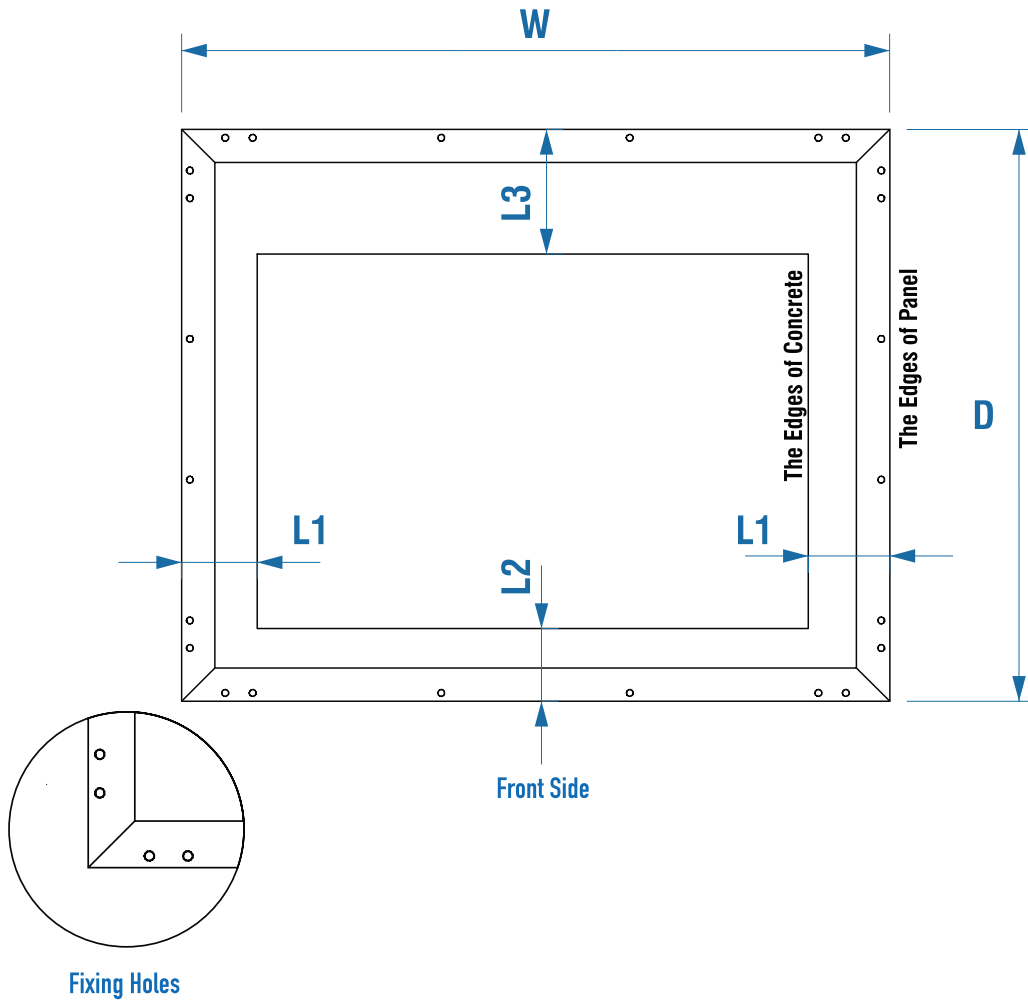

RMU Type	Width (W) mm	Depth (D) mm	L1 mm	L2 mm	L3 mm
3-way Indoor	1200	9	70	75	205
3-way Outdoor	1350	9	105	150	9
4-way Indoor	1575	9	70	75	205
4-way Outdoor	1660	9	105	150	9

alfa-R 36kV

1- Introduction to alfa-R 36kV

A - alfa-R Solution

alfa-R units are designed to supply reliable energy and protect electrical equipment in secondary distribution networks up to 36 kV. alfa-R units are the best solution for indoor/outdoor distribution substations as their compact design makes them suitable for various network applications such as transformer substations, wind power plants, industrial zones, etc.

B. Key Features

- Compact design and type tested.
- High-level operator safety, high-level operation reliability.
- Lower filling SF₆ gas pressure and lower minimum operating SF₆ gas pressure.
- Hermetically sealed pressure system, leakage rate less than % 0.1 per year.
- Resistant to pollution, insensitive to humidity and altitude.
- Modular and compact type (extensible and non-extensible).
- Lower maintenance cost.
- Suitable for remote control and monitoring.
- Comply with relevant IEC and EN standards.
- Compact type RMU's can be manufactured to be extensible for either both sides or for only the left/right side.



C. Safety

- The durable design withstands internal arc, providing protection against thermal and dynamic effects.
- Ability to visually check the position of the Earthing Switch (Close or Open) through the front pane surveillance window.
- Consecutive interlocking systems prevent incorrect operation.
- Access to the cable compartment and fuse compartment is only possible if the related Earthing Switch/Switches are in the earthed position.

2- Operating Conditions and Standards

- alfa-R has an embedded hermetically-sealed gas tank filled with SF6 gas having a lower filling SF6 gas pressure (1,1 bar, abs.) and lower minimum operating SF6 gas pressure (1,05 bar, abs.).
- The expected lifetime of the product is more than 30 years with a leakage rate of less than 0.1 % per year.
- No maintenance or gas refilling is required during the lifetime of the alfa-R.
- The main busbar and switching compartment has an IP 67 protection degree rating whereas the other sections of indoor products are rated at IP 41 and the outdoor products are rated IP 54.

Operating conditions:

- Ambient temperature range from -25 °C to 55 °C
- Altitude range of (0-1000 m)*
- Maximum relative humidity of 100%



alfa-R fully complies with the following IEC Standards used under general operating conditions.

	STANDARDS	CLASSIFICATION	
		Partition	PM
alfa-R 36	IEC 62271-200	Loss of Service Contuinity	LSC 2
		Internal arc	A (FLR) 25 kA-1 s
SWITCH-DISCONNECTOR	IEC 62271-103	General purpose, M2, E3	
CIRCUIT BREAKER	IEC 62271-100	M2, E2 (for cable network)	
DISCONNECTOR	IEC 62271-102	M1, E0	
EARTHING SWITCH	IEC 62271-102	E2	
VOLTAGE DETECTION SYSTEM	IEC 61243-5	Voltage Presence Indicating System (VPIS)	
PLUG-IN BUSHINGS	IEC 50181	Outer cone plug-in bushing	

3- alfa-R Ranges and Dimensions

3.1 alfa-R-SBS-25kA (NON EXTENSIBLE OUTDOOR)

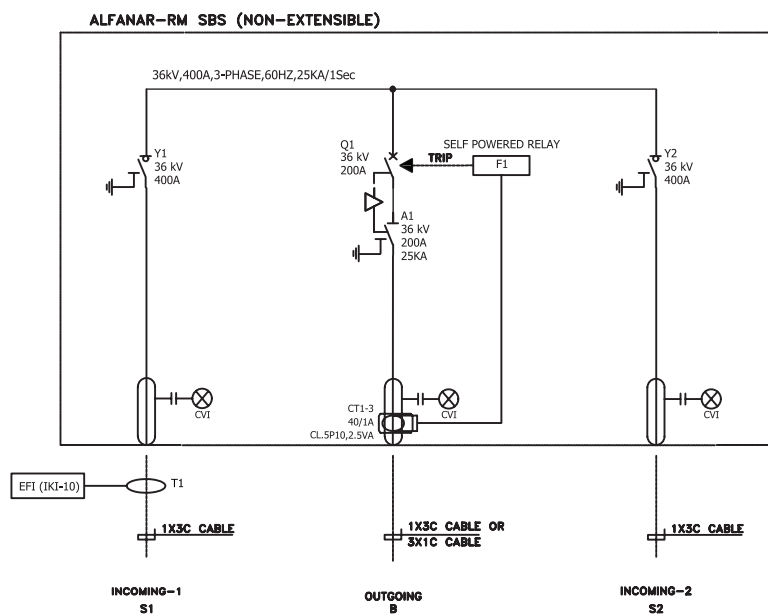
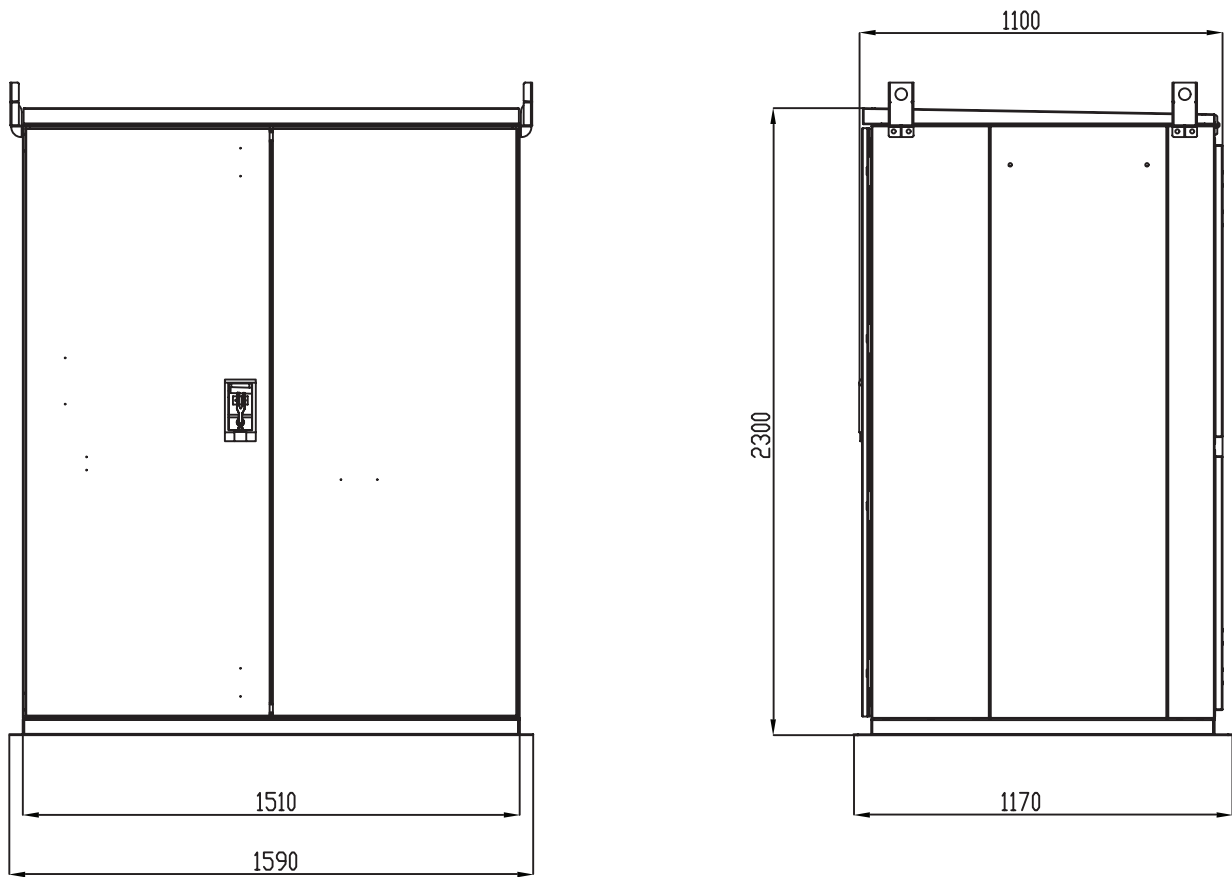

3.2 alfa-R-SSBS-25kA (NON EXTENSIBLE OUTDOOR)

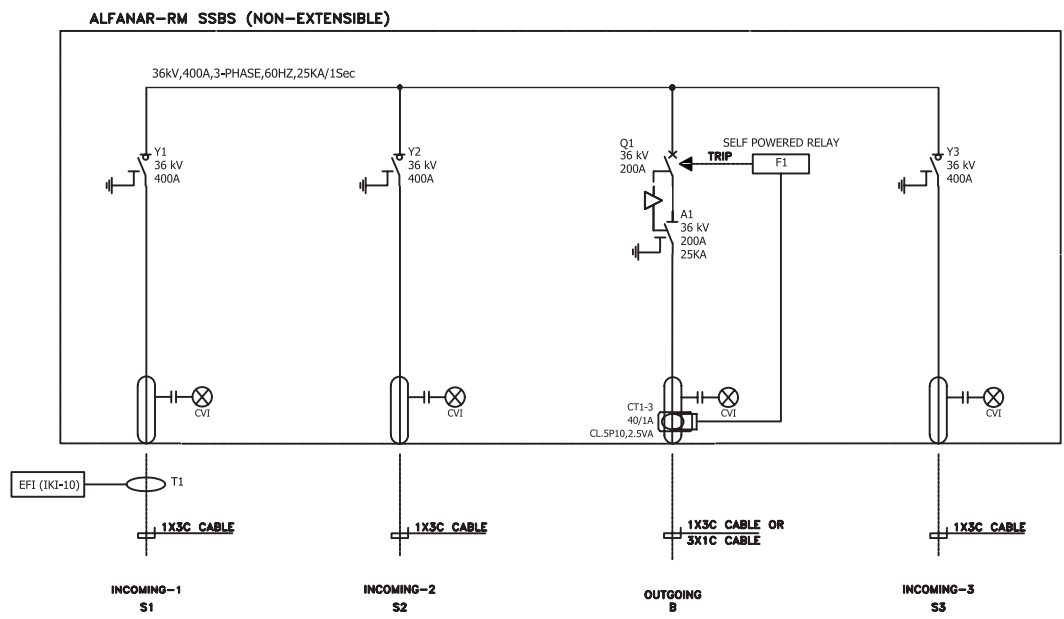
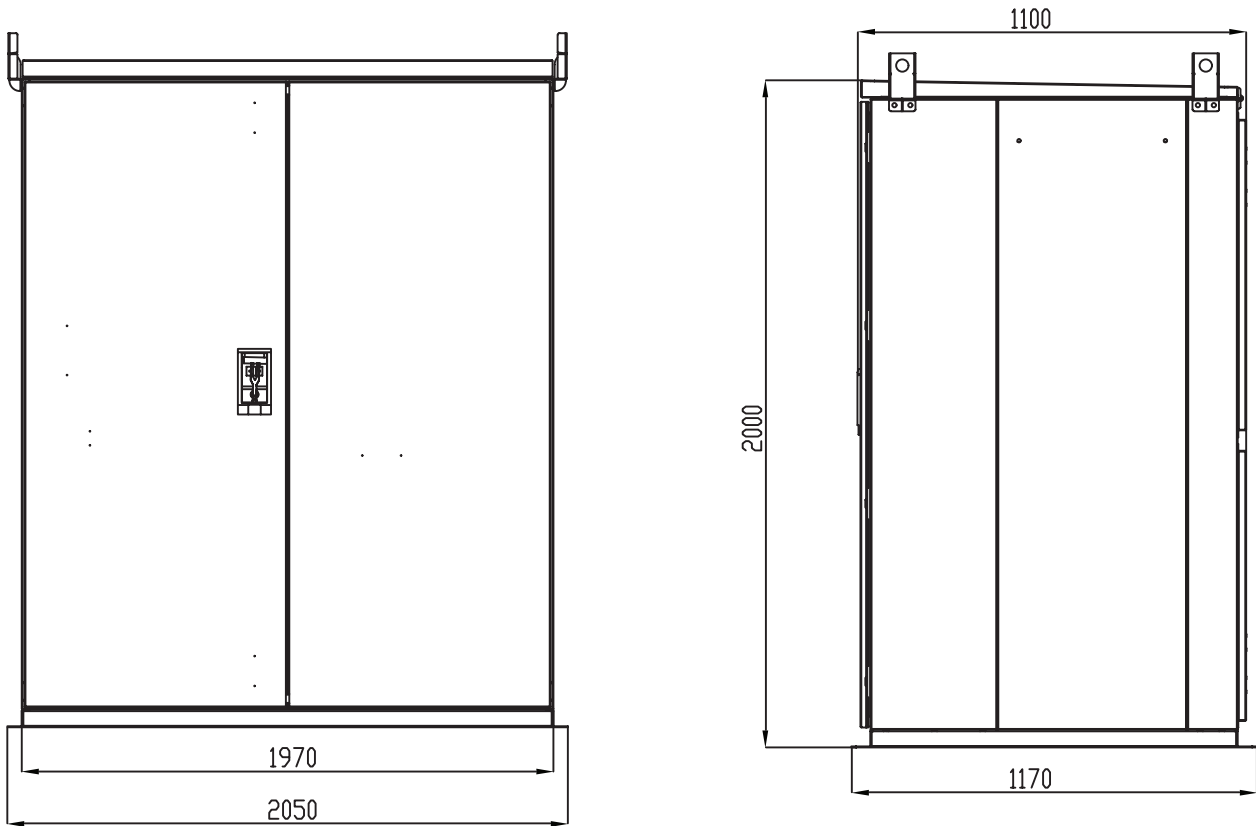

3.3 alfa-R-SBBS-25kA (NON EXTENSIBLE OUTDOOR)

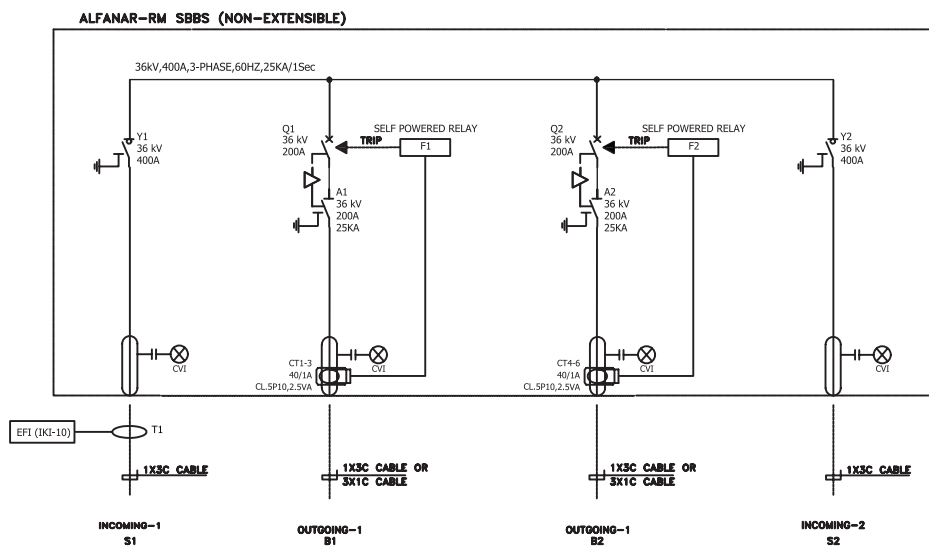
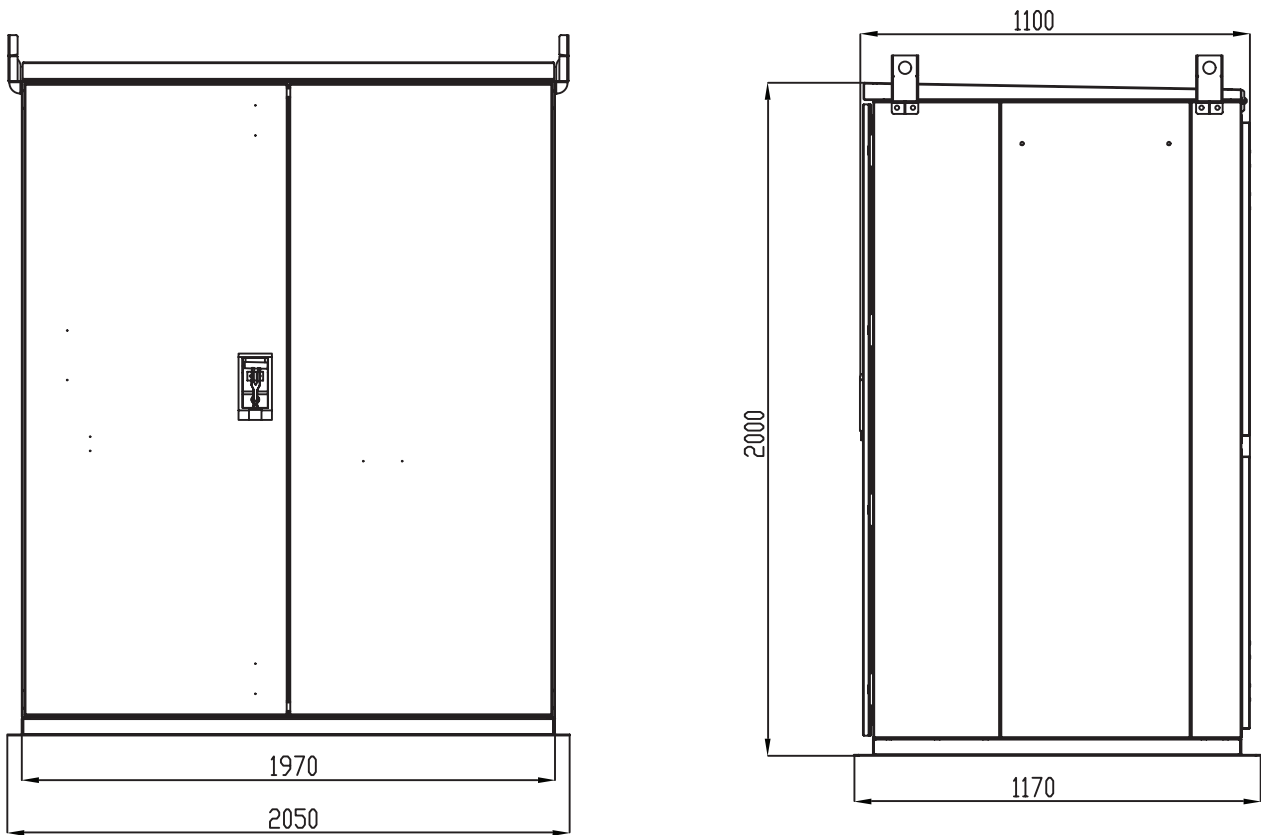

3.4 alfa-R-B-25kA (EXTENSIBLE OUTDOOR) - Modular

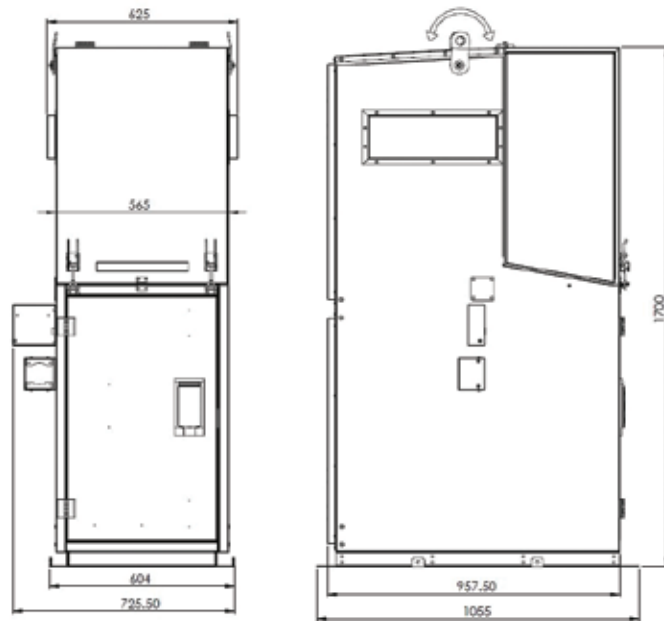

12.5 alfa-R-S-25kA (EXTENSIBLE OUTDOOR) - Modular

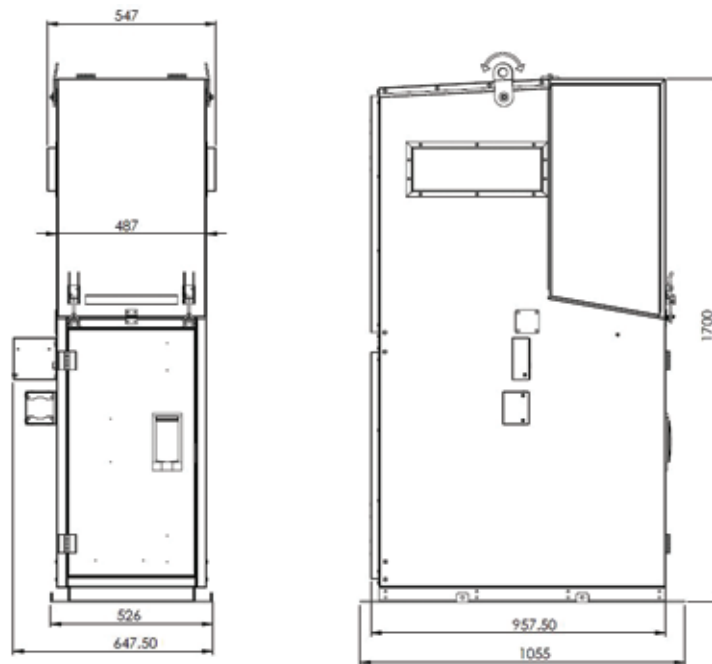

4- Technical Data Sheet

Electrical Characteristics	
Manufacturer	alfanar Electrical Systems
Type	alfa-R
Voltage (Ur)	36 kV
Insulation level	
- power frequency withstand voltage (Ud) – common value	70 kVrms
- power frequency withstand voltage (Ud) – across the isolating distance	80 kVrms
- lightning impulse withstand voltage (Up) – common value	170 kVpeak
- lightning impulse withstand voltage (Up) – across the isolating distance	200 kVpeak
Frequency (fr)	50/60 Hz
Normal current (Ir)	630 A
Short-time withstand current for main (Ik) and earthing circuits (Ike)	25 kA
Peak withstand current for main (Ip) and earthing circuits (Ipe)	65 kA
Duration of short circuit (tk – tke)	1 s
Internal arc classification (IAC) (type of accessibility and classified sides)	AFLR
Arc fault current (IA)	25 kA
Arc fault duration (tA)	1 s
Partition class	PM
Loss of service continuity category	LSC 2
Degree of protection	IP54/IP41
Type of application	indoor/outdoor
Rated supply voltage of auxiliary and control circuits (Ua)	DC 24 V
Type of neutral earthing	Solidly earthed neutral

Technical Data Sheet

Load Break Switch

Electrical Characteristics

Manufacturer	alfanar Electrical Systems
Type	alfa-L
Voltage (Ur)	36kV
Insulation level	
- power frequency withstand voltage (Ud) – common value	70 kVrms
- rated impulse withstand voltage	170 kVrms
Main active load breaking current	630A
Closed loop breaking current	630A
Cable charging breaking current	20A
Short-time withstand current for main (Ik) and earthing circuits (Ike)	25 kA
Peak withstand current for main (I _p) and earthing circuits (I _{pe})	65 kA
Duration of short circuit (tk – tke)	1 s
Mechanical endurance	M1
Electrical endurance	E3
Weight	70 Kg
Short circuit duration	1 s
Earth fault breaking current	60A
Operating mechanism	alfa-L
Closing device	24 VDC
Opening device	24 VDC
Motor	24 VDC

Technical Data Sheet

Vacuum Circuit Breaker

Electrical Characteristics	
Manufacturer	alfanar Electrical Systems
Type	alfa-V
Voltage (Ur)	36kV
Insulation level	
- power frequency withstand voltage (Ud) – common value	70 kVrms
- rated impulse withstand voltage	170 kVrms
DC component (referred to time constant = 45 ms)	25%
Minimum opening time	33 ms
Frequency (fr)	50/60 Hz
Normal current (Ir)	630 A
Short-time withstand current for main (Ik) and earthing circuits (Ike)	25 kA
Peak withstand current for main (I _p) and earthing circuits (I _{pe})	65 kA
Duration of short-circuit (tk – tke)	1 s
Mechanical endurance	M2
Electrical endurance	E2
Weight	90 kg
Rated operating sequence	O-0.3-CO3min-Co
Applied standard	IEC 62271-100
Operating mechanism	alfa-V
Closing device	24 VDC
Opening device	24 VDC
Motor	24 VDC

5- Main Components

Compact alfa-R units are an excellent solution for secondary distribution networks. The units cover all medium voltage functions such as connection, supply and protection of MV equipment for different applications.

Standard Equipment

- (two) feeders with Switch-disconnector:

- Switch-disconnector (three-positioned, open-closed-earthed)
- Integrated capacitive Voltage Presence Indicator System.
- Operating mechanism
- Interface C bushings

- (one) pc feeder with Vacuum Circuit Breaker:

- Vacuum circuit breaker
- Disconnecter with earthing switch
- Over current and earth fault relay
- Current transformer
- Integrated capacitive Voltage Presence Indicator System
- Operating mechanism
- Interface C bushings

- SF6 Gas Pressure Manometer

- Main Busbar, Earthing Bar

- Operating Handle

- Pad-locking facility



Optional Equipment

- SF6 Gas Pressure Manometer (hermetic and double contact)
- Remote OPENING and CLOSING operation with cable
- Motor + Gear Box

For Extensible Type Compacts RMU's

- Extension Boots
- Extension Bar
- Screened Plug

SLD

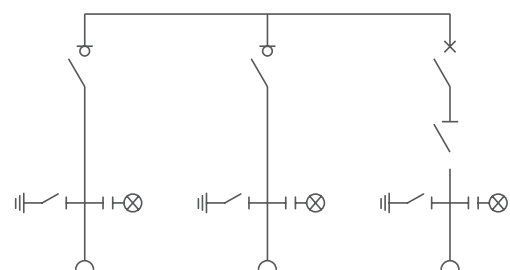

6- Control Panels

15.1 For Cubicle with Switch-Disconnecter

1. Position indicator for switch-disconnector
2. Operating handle slot for switch-disconnector
3. Operating handle slot for earthing switch
4. Pad-locking
5. Position indicator for earthing switch

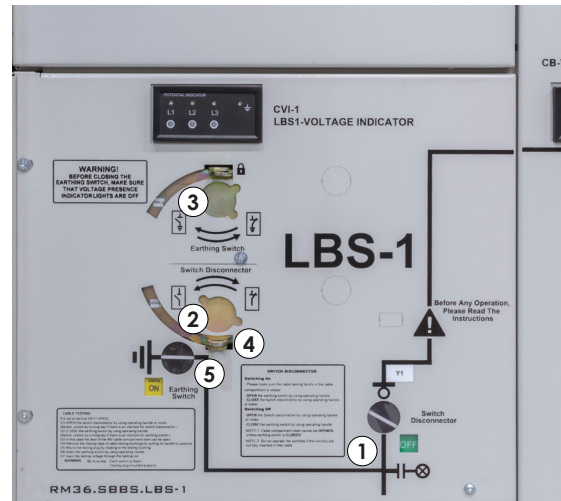

15.2 For Cubicle with Vacuum Circuit Breaker

1. Position indicator for circuit breaker
2. Operating handle shaft for charging spring
3. Operating handle shaft for disconnecter
4. Operating handle shaft for earthing switch
5. Thump knot for OPENING and CLOSING
6. "Spring Charged" or "Spring Discharged" indicator for switch disconnector
7. SF6 Gas manometer
8. Padlocking
9. Position indicator for earthing switch
10. Voltage presence indicator
11. Position indicator for disconnecter

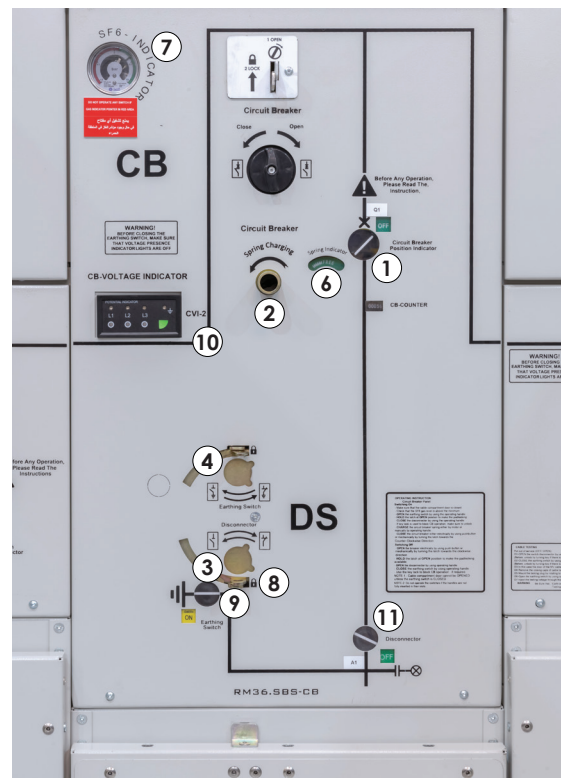

7- MV Cables Connections

Cables connections of the alfa-R.36 is done in the Cables Connections Compartment which is located at the front of the cubicle using Separable Cable Connectors.

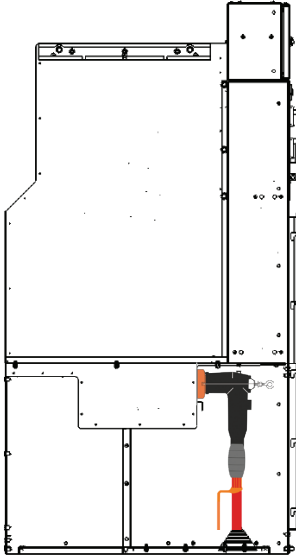

Separable Connector Type “L”

Contact Type: Bolted
Rated Current: 630 A
Interface: C

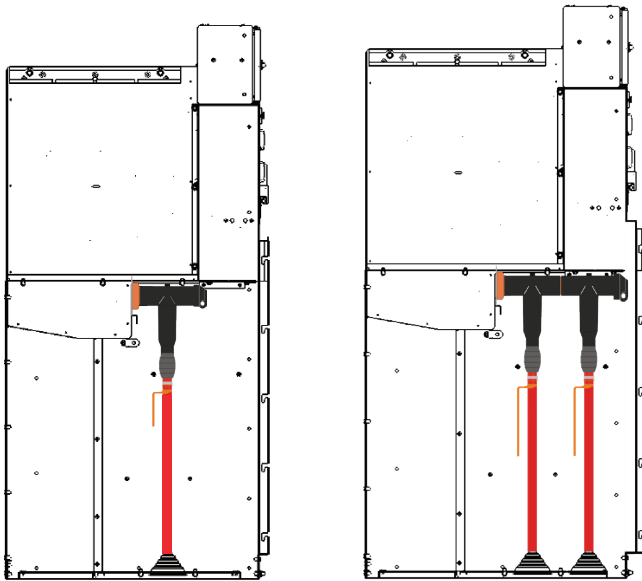

Separable Connector Type “T”

Contact Type: Bolted
Rated Current: 630 A
Interface: C



WARNING!

1. Separable connectors should have type test reports/certificates according to the related standards.
2. Manufacturer's installation instructions must be followed.
3. Metal screen of the HV cable should be connected to the earthing bar of the cubicle.

Smart RMU up to 36 kV

1- Introduction to Smart RMU

A - Smart RMU

alfa-R - Smart has an integrated (RTU) to provide remote monitoring and control capability via the control center.

Connection between the local RTU and control center is established over a secured Virtual Private Network connection (VPN) or through an access point named "APN"

B. Key Features

The exchanged data

- Status information from RTU to data center
- Control signal from control center to RTU
- Analog measurements

Status information from RTU to data center

- Close/Open for each CB/LBS
- Earth status for each circuit
- Lock /Unlock for each circuit
- Selector switch status local/remote
- SF6 Gas pressure low/normal
- Power supply status
- Door Open/Close

Control command from control center to RTU

- Close/Open for each circuit
- Lock/Unlock for each circuit

Analog measurements

- V_ phase (A,B,C)
- I_ phase (A,B,C)
- Frequency
- Total active power [kW]
- Total reactive power [kVAR]
- Total apparent power [kVA]



2- Product Breakdown

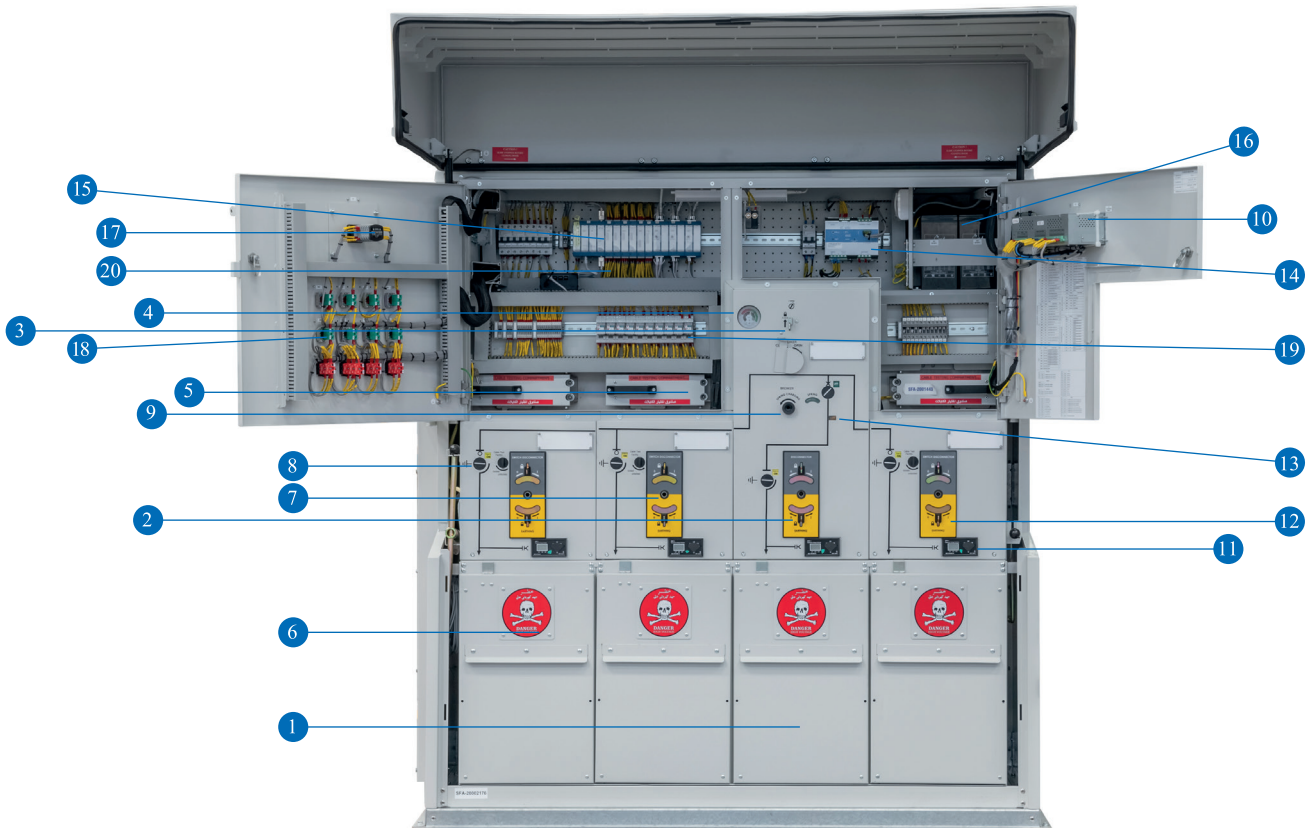

- | | |
|--|------------------------------------|
| 1. Tee-Off Switch Cable Compartment | 11. Voltage Presence Indicator |
| 2. Disconnecter Switch | 12. Shutter Padlock Facility |
| 3. Vacuum Circuit Breaker | 13. Operating Counter |
| 4. Gas Pressure Indicator | 14. Battery Charger |
| 5. Cable Test Compartment | 15. RTU |
| 6. Ring Switch Cable Compartment | 16. Batteries |
| 7. Switch-disconnector Operation (Motor Optional*) | 17. Local / Remote Selector Switch |
| 8. Interlocking Knob for Cable Test Compartment | 18. Indication Lamps |
| 9. Circuit Breaker Operation (Motor Optional*) | 19. Interposing Relays |
| 10. Protection Relay | |

3- Dimensional Drawings

3.1 Smart RMU 17.5 kV

SBS 3-Way Outdoor Type RMU

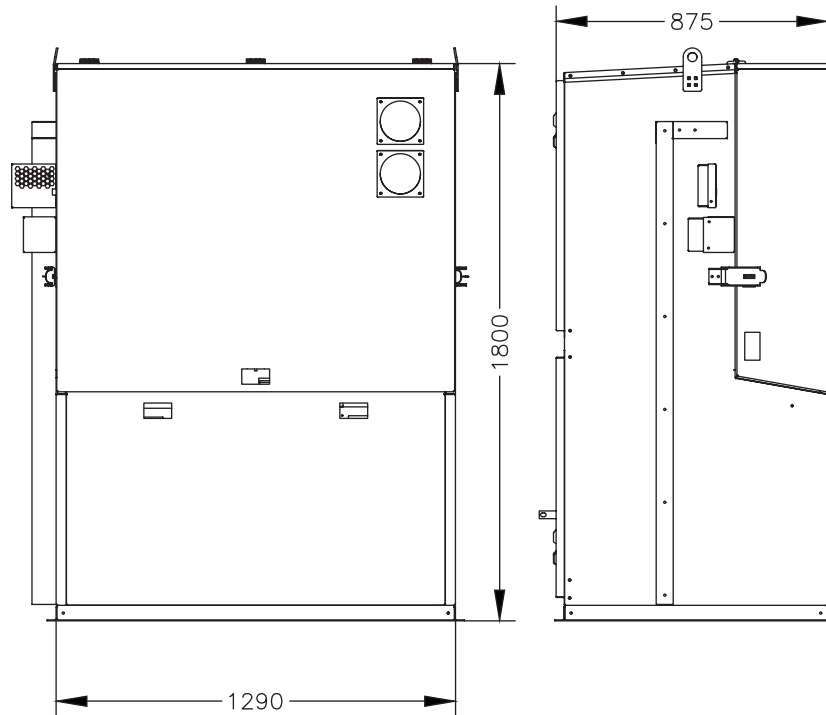

17.5 kV, 2 ring switches up to 630A + 1 vacuum circuit breaker up to 630A

SBBS and SSBS 4-Way Outdoor Type RMU

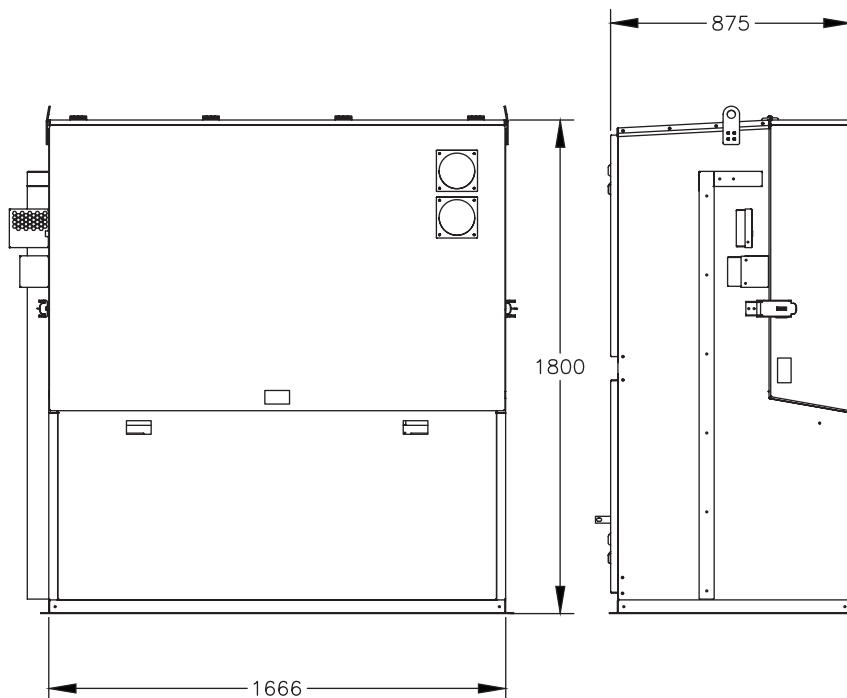

17.5 kV, 2 ring switches up to 630A + 2 vacuum circuit breakers up to 630A

17.5 kV, 3 ring switches up to 630A + 1 vacuum circuit breaker up to 630A

3.2 Smart RMU 36 kV SBS 3-Way Outdoor Type RMU

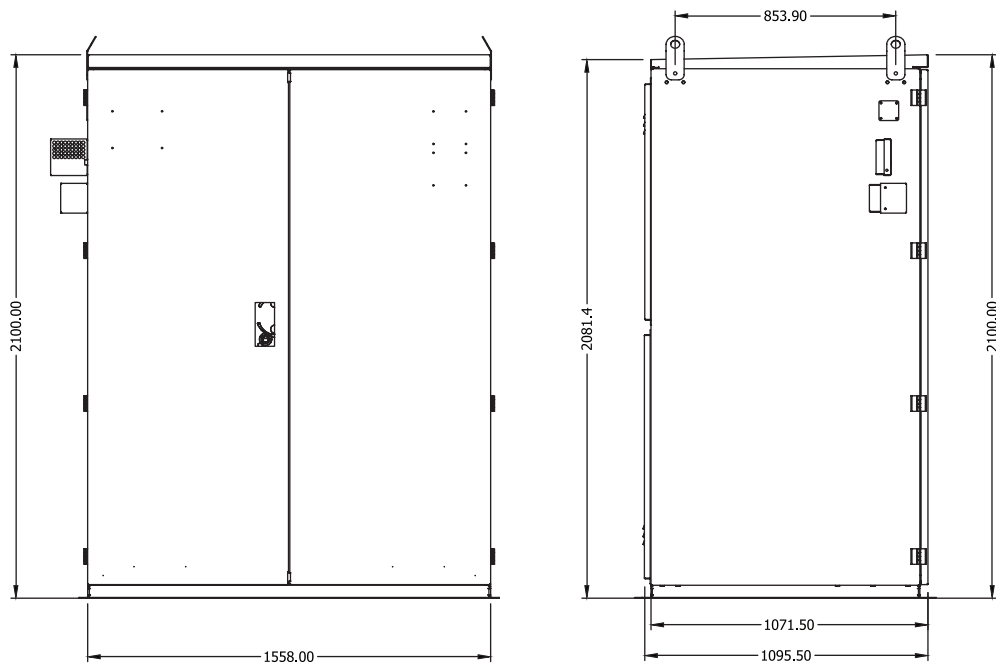

36 kV, 2 ring switches up to 630A + 1 vacuum circuit breakers up to 630A

SBBS 4-Way Outdoor Type RMU

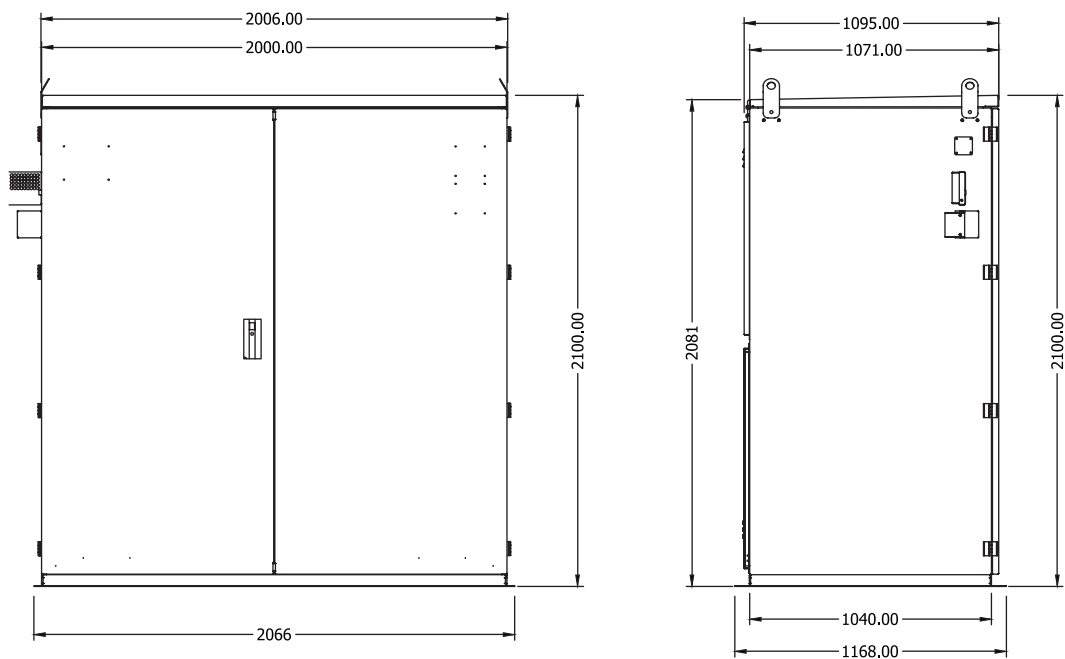

36 kV, 2 ring switches up to 630A + 2 vacuum circuit breakers up to 630A

3.3 Smart RMU 36 kV SSBS 4-Way Outdoor Type RMU

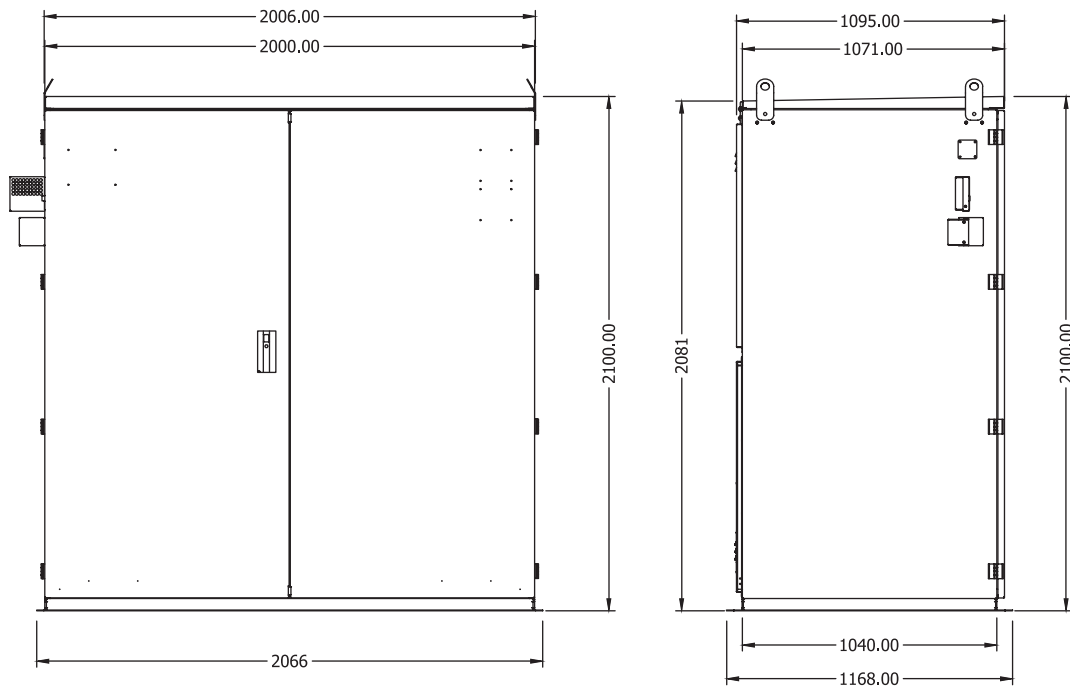

36 kV, 3 ring switches up to 630A + 1 vacuum circuit breakers up to 630A

SSS 3-Way Outdoor Type RMU

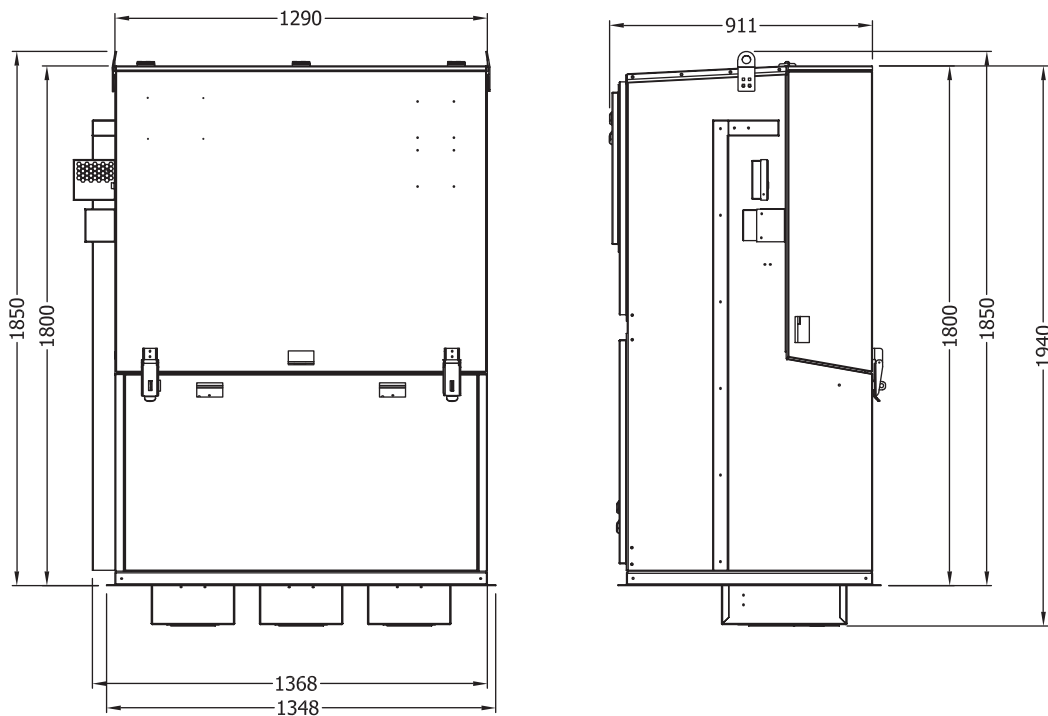

36 kV, 3 ring switches up to 630A

**3.4 Smart RMU 36 kV
SSSS 4-Way Outdoor Type RMU**

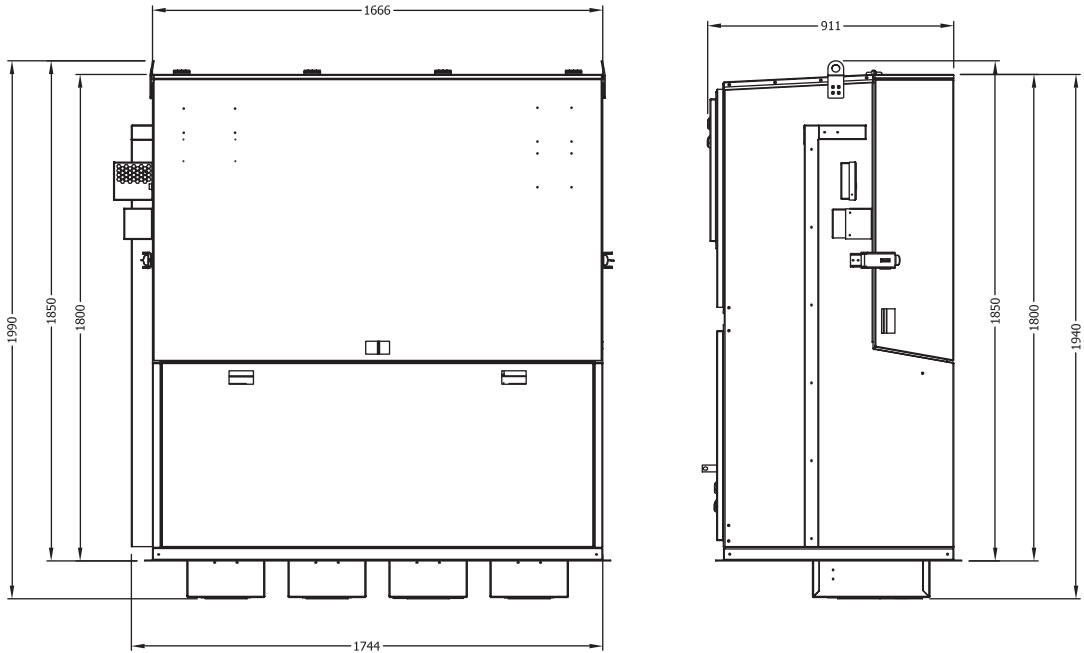

36 kV, 4 ring switches up to 630A

4- Technical Data Sheet

4.1: Smart RMU 17.5 kV

Rated Voltage	17.5 kV	
Busbar Rating	400 / 630 A	
Rated Frequency	50 / 60 Hz	
Rated Nominal Current For Ring Switch	400 / 630 A	
Rated Nominal Current For Tee-off Feeder	200 / 400 / 630 A	
Rated Short Time Withstand Current	21 kA / 1s	
Internal Arc Calcification	A (FL) 21kA / 1s indoor A (FLR) 21kA / 1s outdoor	
Rated Filling SF6 Gas Level For Insulation	1.3 bar (absolute)	
Minimum Functional SF6 Gas Level	1.1 bar (absolute)	
Relative Humidity	100 %	
IP Class (Gas Tank / Indoor / outdoor)	IP 67 / IP41 / IP54	
Rated Lightning Impulse Withstand Voltage	95 kV-peak	
Rated Power Frequency Withstand Voltage	38 kV-rms	
Applied Standard	IEC 62271-200	
Load Break Switch	Type of Switch-Disconnecter (OPEN-CLOSED-EARTHED)	General purpose, three-positioned (OPEN-CLOSED-EARTHED) E3 / E0
	Mechanical Endurance	M2
	Nominal Current	400 / 630 A
	Short Circuit Making Current	21 kA (also valid for earthing switch) 54.6kA Peak
	Applied Standard	IEC 62271-103/102
	Circuit Breaker	Type of Breaker
Electrical Endurance		E2
Mechanical Endurance		M1
Nominal Current		200 / 400 / 630 A
Short Circuit Breaking Current		21 kA
Applied Standard		IEC 62271-100

4.2: Smart RMU 36 kV

Rated Voltage	36 kV	
Busbar Rating	400 / 630 A	
Rated Frequency	50 / 60 Hz	
Rated Nominal Current For Ring Switch	400 / 630 A	
Rated Nominal Current For Tee-off Feeder	200 / 400 / 630 A	
Rated Short Time Withstand Current	25 kA / 1s	
Internal Arc Calcification	A (FL) 25kA / 1s indoor A (FLR) 25kA / 1s outdoor	
Rated Filling SF6 Gas Level For Insulation	1.3 bar (absolute)	
Minimum Functional SF6 Gas Level	1.1 bar (absolute)	
Relative Humidity	100 %	
IP Class (Gas Tank / Indoor / outdoor)	IP 67 / IP41 / IP54	
Rated Lightning Impulse Withstand Voltage	170 kV-peak	
Rated Power Frequency Withstand Voltage	70 kV-rms	
Applied Standard	IEC 62271-200	
Load Break Switch	Type of Switch-Disconnecter (OPEN-CLOSED-EARTHED)	General purpose, three-positioned (OPEN-CLOSED-EARTHED) E3 / E0
	Mechanical Endurance	M1
	Nominal Current	400 / 630 A
	Short Circuit Making Current	25 kA (also valid for earthing switch) 65kA Peak
	Applied Standard	IEC 62271-103/102
	Circuit Breaker	Type of Breaker
Electrical Endurance		E2
Mechanical Endurance		M2
Nominal Current		200 / 400 / 630 A
Short Circuit Breaking Current		25kA
Applied Standard		IEC 62271-100

Compact RMU up to 17.5 kV

1- Introduction to Smart RMU

A - Smart RMU

alfa-R is designed and tested as per the new IEC standard 62217-200. This panel is available up to 630A, 21kA/ 1 sec.

alfa-R is GIS Type (SF6) Insulation, complies with the highest quality requirements and are factory-assembled and type-tested in accordance with IEC 62271-1, 62271-200 and 62271-100 and SEC 32-SDMS-01, 32-SDMS-04 and 32-SDMS-11 Standards.

B. Key Features

- Compact design up to 17.5 kV; CESI type tested
- Switching units sealed in SF6 gas filled stainless steel tank
- High level operator safety and operating reliability
- Embedded cable testing compartment, easy and safe cable testing without cable connection removal
- High quality tank welding, leakage rate of less than 0.1% per year
- Maintenance free unit offering a life expectation of over 30 years
- Smart interlocking padlocking system for maximum operator safety
- Different feeder combinations with switch disconnecter and vacuum circuit breaker
- Compatible with SCADA systems for remote control and monitoring
- Motorized options for circuit breakers and switches
- High resistance to pollution and humidity



2- Dimensional Drawings

Compact RMU 17.5 kV
SBS 3-Way Outdoor Type RMU

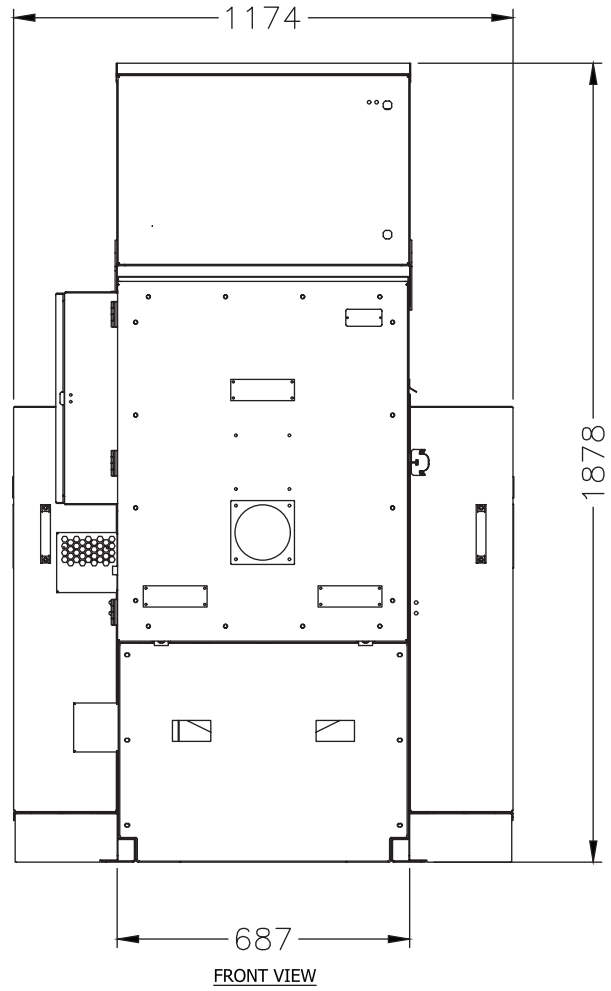
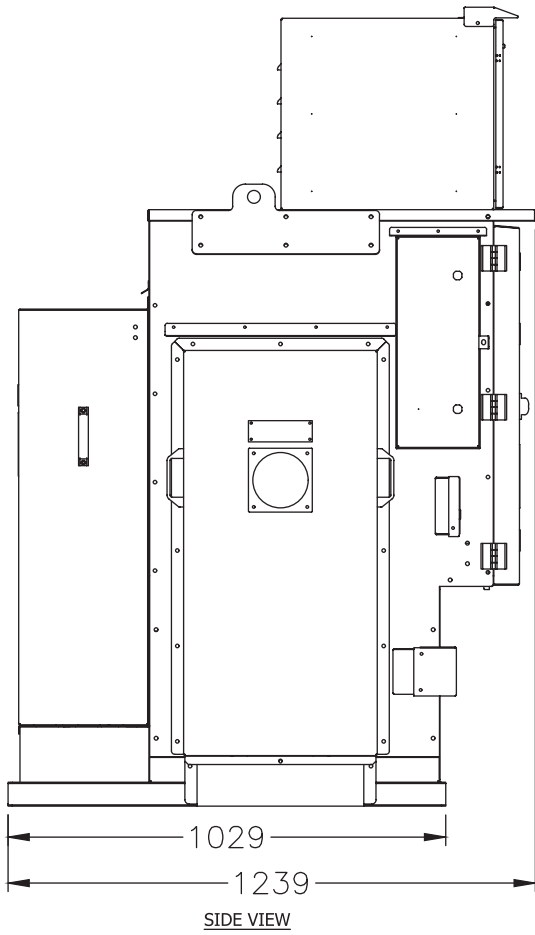

3- Technical Data Sheet

Compact RMU 17.5 kV

Rated Voltage	17.5 kV	
Busbar Rating	400 / 630 A	
Rated Frequency	50 / 60 Hz	
Rated Nominal Current For Ring Switch	400 / 630 A	
Rated Nominal Current For Tee-off Feeder	200 / 400 A	
Rated Short Time Withstand Current	21 kA / 1s	
Internal Arc Calcification	A (FL) 21kA / 1s indoor A (FLR) 21kA / 1s outdoor	
Rated Filling SF6 Gas Level For Insulation	1.3 bar (absolute)	
Minimum Functional SF6 Gas Level	1.1 bar (absolute)	
Relative Humidity	100 %	
IP Class (Gas Tank / Indoor / outdoor)	IP 67 / IP41 / IP54	
Rated Lightning Impulse Withstand Voltage	95 kV-peak	
Rated Power Frequency Withstand Voltage	38 kV-rms	
Applied Standard	IEC 62271-200	
Load Break Switch	Type of Switch-Disconnecter	General purpose, three-positioned (OPEN-CLOSED-EARTHED)
	(OPEN-CLOSED-EARTHED)	E3 / E0
	Mechanical Endurance	M2
	Nominal Current	400 / 630 A
	Short Circuit Making Current	21 kA (also valid for earthing switch) 54.6 kA Peak
	Applied Standard	IEC 62271-103/102
Circuit Breaker	Type of Breaker	Vacuum
	Electrical Endurance	E2
	Mechanical Endurance	M1
	Nominal Current	200 / 400 A
	Short Circuit Breaking Current	21 kA
	Applied Standard	IEC 62271-100

4- Installation / Foundation View

The floor must be well leveled and the unit must be fixed with anchor bolts in accordance with the dimensional drawing for the number of modules or units as appropriate.

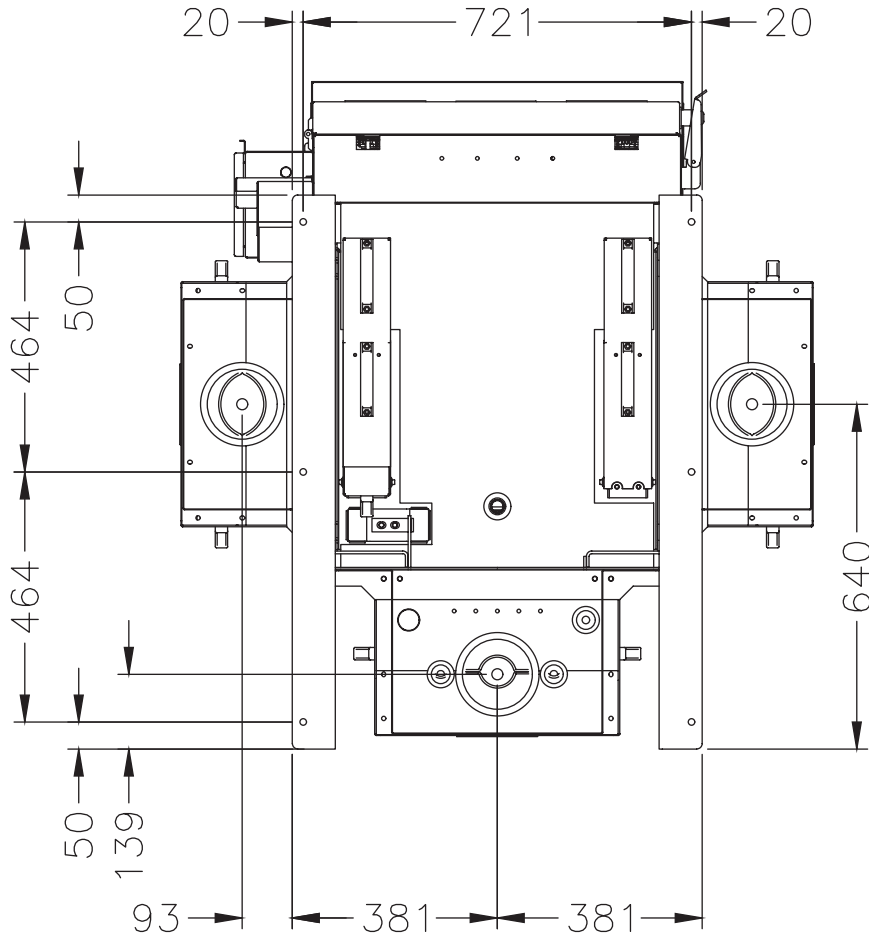

Dimension	W mm	D mm	H mm
LBS cable box	455	245	955
Tee-off cable box	453	306	980

5- Main Components

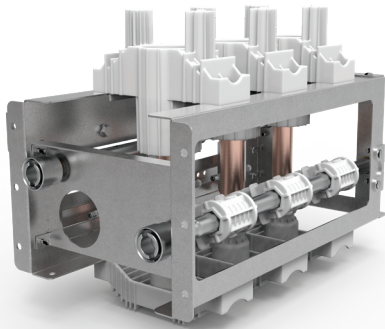

5.1 SWITCH-DISCONNECTOR (with earthing switch)

- Applied Standard: IEC 62271-103
- Three-phase, three positioned (OPEN-CLOSE-EARTHED)
- Load current is quenching in the SF6
- Electrical Endurance Class: E3
- Electrical Endurance Class: E2 (for earthing switch)
- Mechanical Endurance Class: M2

Operating Mechanism of The Switch-Disconnecter

- Stored energy operation
- Standard mechanism: Type M018
- Optional mechanism: Type M019
- Independent of the operator operation
- Comply to motor specifications

M018 Type Mechanism

• Opening and Closing operation takes place at one stage. The position of the switch (closing, opening and earthing operation) is performed manually using the operating handle. For motorized types, mentioned operation is performed via geared motor.

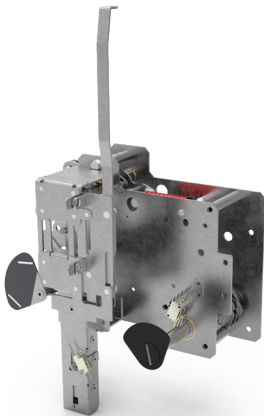

M019 Type Mechanism

• Energy storage is performed by the operator using the operating handle or via geared motor (for motorized mechanism)

Releasing of the energy is performed;

- By operator using push button (mechanically)
- By shunt coils (electrically)

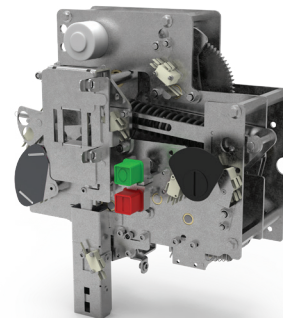

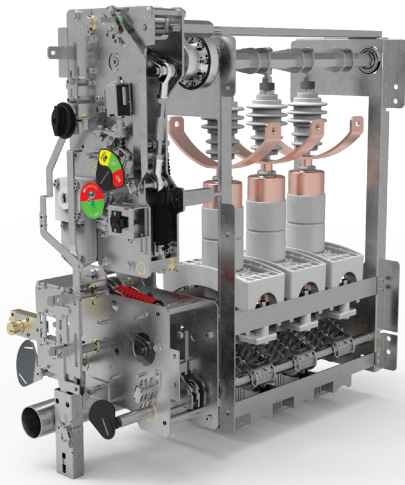

5.2 VACUUM CIRCUIT BREAKER+DISCONNECTOR WITH EARTHING SWITCH UNIT

Vacuum Circuit Breaker

- Applied Standard: IEC 62271-100
- Electrical Endurance Class: E2
- Mechanical Endurance Class: M1

Disconnecter

- Applied Standard: IEC 62271-102
- Three-phase, three positioned (OPEN-CLOSED-EARTHED)
- Mechanical Endurance Class: M2

Earthing Switch

- Applied Standard: IEC 62271-102
- Electrical Endurance Class: E2

OPERATING MECHANISM OF THE VACUUM CIRCUIT BREAKER

- Operating mechanism is based on stored energy within a spring. Storing of energy is provided with either a geared motor (electrically) or with an operating handle (manually). Releasing of energy is conducted using either the push button on the front panel (manually) or using a shunt coil (electrically)
- During the breaker closing operation , the closing spring charges both of the spring of opening and the spring of trip-coil
- Suitable for rapid re-closing
- Suitable for self-powered relay application

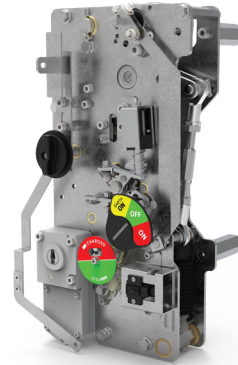

AUXILIARY SERVICE VOLTAGES

	VOLTAGE*
Motor	220 VAC; 220 VDC; 110 VDC; 24 VDC; 48 VDC
Coil	24 VDC; 48 VDC; 110 VDC

*Contact **alfanar** if different service voltage is required.

5.3 - Gas Pressure Indicator

Gas density is an important operating parameter for SF₆ insulated MV equipment. If the required gas density is not sufficient, safe operation cannot be guaranteed. On alfa-R units, a gas pressure indicator is fitted to the tank to provide a reliable warning indication against low gas levels. The gas pressure indicator shows the minimum pressure for safe operation.



5.4 - Voltage Presence Indication System

All alfa-R units are integrated with a voltage presence indication system. A voltage signal comes from the VPIS through the voltage divider positioned in the cable entrance of bushings.

The VPIS can be used to check whether a voltage is present across the cables.



5.5 - Protection Relay

Overcurrent Protection

1- 50P/50N Function: Phase/Neutral Instantaneous Overcurrent

Time of operation is independent from the current of operation flowing through the relay. Hence, if the phase current increases more than its determined value for an equal or greater amount of time than the specified value, then protection function activates (trips) and does not reset itself till the value of the phase drops below the point of current pick-up.

The function activates at 100% of the pre-set input, and deactivates at 95%, where the reset is instantaneous.

The accuracy of the operating time is equal to the present time plus a maximum of 30 ms.

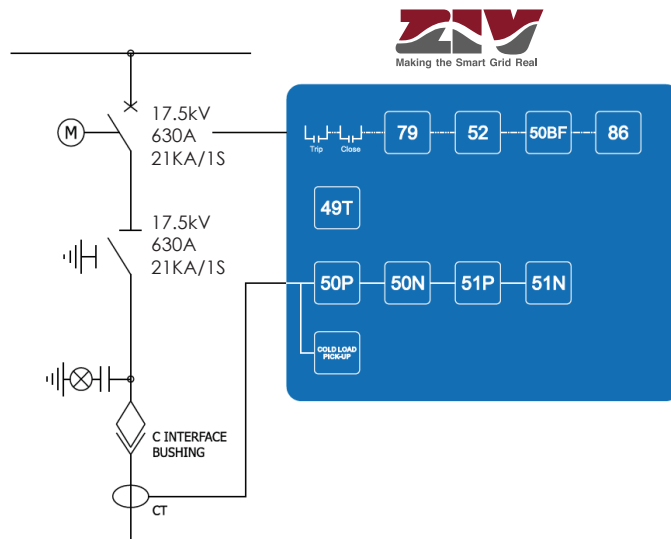

2- 51P/51N Function: Phase/Neutral Time Overcurrent Protection

A - Definite Time O/C Protection



If the option “Definite time” is selected for the curve setting, the unit operating time is set by the parameter “Operating time” to trip the fault after a preset specific time setting.

If the unit operates with defined time, the function is activated at 100% of the set tap value, and it deactivates at 95%. If the unit operates with a curve, the function is activated at 110% of the set pick-up value, and it deactivates at 100%. The reset is instantaneous in both cases. The activation time is accurate to $\pm 5\%$ or $\pm 30\text{ms}$, whichever is greater, of the theoretical activation time. The curves used are IEC 60255-151.

B - Inverse Time O/C Protection (IDMT)

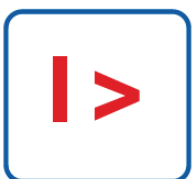

If a curve (e.g. inverse, very inverse or extremely inverse) is selected for the curve setting, the operating time principally depends on the current value which is set through the curve type, and dial and tap settings.

6- Accessories

6.1 - Operating Handles

In alfa-R units, there are two operating handles; the first one is for the operation of the load break switch and the second is for charging the spring of vacuum circuit breaker. The design of the operating handles enables a safe and easy operation for the user.



Switch Disconnector & Disconnector Operating Handle



Circuit Breaker Spring Charging Handle

6.2 - IR / PD Windows

The alfa-RU can be optionally equipped with IR & PD Windows, a new feature that complies with the new requirements of the Saudi Electric Company.

The inclusion of an infrared inspection window is considered a very effective method for maintenance personnel to identify any possible problems with loose electrical terminations without the need to shut down the RMU. The window consists of polymer and mesh optics to allow thermal infrared inspection by employing broadband media.

The inclusion of a partial discharge window is to facilitate the ability to measure partial discharge of a live RMU and estimate the expected life of insulation components.



6.3 - Motorization Kit (LBS / VCB)

Motors with gearboxes can easily be installed to load break switches and circuit breaker mechanisms either in the factory or on-site. A built-in electrical interlocking system prevents any unintentional operations.

When the unit is installed with the motor mechanism, it can be used with intelligent systems such as SCADA, DAS, etc. With the help of a selector switch, alfa-R units can be controlled remotely by choosing the remote control option.



Motor with Gearbox

6.4- Earth Fault Indicator (EFI)

EFI can also be implemented in alfa-R units. EFIs help the operator to easily find the fault location in medium voltage ring networks.

Earth fault is indicated with a LED flashlight and a flag when asymmetrical currents are detected in three phase cables.

EFI is fed via either auxiliary supply with internal batteries or a core balance current transformer.

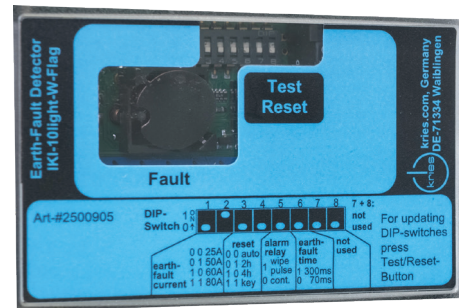

EFI

6.5- Operation Counter for Load Break Switch Mechanism

In alfa-R units, implementation of an operation counter for mechanical operation of load break switches is available as an option.

6.6 - CVI Auxiliary Contacts

To automate voltage indication in alfa-R units, auxiliary contacts could be integrated with CVI units. This feature makes it suitable for alfa-R to accommodate the following:

Absence of voltage applications

- Alarms on voltage loss
- Automatic transfer systems

Presence of voltage applications

- Earth locking on presence on voltage
- Alarms on voltage presence



CVI Auxiliary Contacts

6.7 - Gas Pressure Indicator with Contacts

As an optional feature a gas pressure indicator with electrical switch contacts can be implemented.

The gas pressure indicator warns the operator when the gas density drops below the defined "alarm" level.



Gas Pressure Indicator

7- Control and Measuring Function

alfa-R - Smart has an integrated (RTU) to provide remote monitoring and control capability via the control center.

Connection between the local RTU and control center is established over a secured Virtual Private Network connection (VPN) or through an access point named "APN".



The exchanged data

- Status information from RTU to data center
- Control signal from control center to RTU
- Analog measurements

Status information from RTU to data center

- Close/Open for each CB/LBS
- Earth status for each circuit
- Lock /Unlock for each circuit
- Selector switch status local/remote
- SF6 Gas pressure low/normal
- Power supply status
- Door Open/Close

Control command from control center to RTU

- Close/Open for each circuit
- Lock/Unlock for each circuit

Analog measurements

- V_ phase (A,B,C)
- I_ phase (A,B,C)
- Frequency
- Total active power [kW]
- Total reactive power [kVAR]
- Total apparent power [kVA]

8- Smart alfa-R, Main Component

a) ZIV-TCA/D (RTU with built-in directional Fault Passage Indicator)



Key Features of ZIV-TCA/D

- 1 - Powerful programmable logic engine.
- 2 - 2500 event log and five Fault Registers (TCA-D/E 4000).
- 3 - Oscillography recorder (five COMTRADE files and a sampling rate of 7200 Hz).
- 4 - Diagnosis and Maintenance WebUI.
- 5 - TCA-D/E:
 - Up to 5 FPI functions per IED.
 - Up to 64 digital inputs.
 - 16 configurable digital outputs for alarm signalling or LBS control commands.
 - 24 analogue channels.
 - Voltage measurement supported directly in busbar or installed in feeder bushings.
 - 4000 event logger and oscillography recorder function (sample rate 4800 Hz).
 - Fault Isolation Automatism (FIA).
 - Cybersecurity: authentication and encryption

b) Power supply and batteries

SFA Smart-RMU is equipped with battery charger powered by external AC supply. All the equipment such as aux relays, RTU, modem, and trip close motor coils are operated by a 24VDC which comes from a AC/DC converter capable of providing sufficient power. This unit has a battery system to ensure sustainability of the power supply.



c) ZIV-IRS (Self-Powered Overcurrent Protection)

Where a dependable auxiliary power source is not available, the IRS Relay can be energized either directly from Main Current Transformers, AC/DC Auxiliary Voltage or through the USB Front Port.

Notes

A series of horizontal dotted lines for writing notes.

Notes

A series of horizontal dotted lines for writing notes, spanning the width of the page.

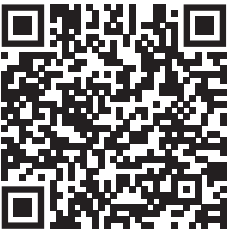

Scan the QR to download the catalogue

228070_alfaR_Oct.2025