

Medium Voltage

Power Cables



Technical Catalogue

Index

1 Introduction

Preface	
General Information	Page 01
Definitions	Page 02
Introduction to XLPE Insulated Cables	Page 03
Design of Medium Voltage Cables	Page 06
Construction of Medium Voltage Cables	Page 08

2 Medium Voltage Cables

3.6/6 kV Single-core & Three-core Cables, Unarmoured With Copper Conductors	Page 13
3.6/6 kV Single-core & Three-core Cables, Tape Armoured With Copper Conductors	Page 17
3.6/6 kV Single-core & Three-core Cables, Wire Armoured With Copper Conductors	Page 21
3.6/6 kV Single-core & Three-core Cables, Unarmoured With Aluminum Conductors	Page 25
3.6/6 kV Single-core & Three-core Cables, Tape Armoured With Aluminum Conductors	Page 29
3.6/6 kV Single-core & Three-core Cables, Wire Armoured With Aluminum Conductors	Page 33
6/10 kV Single-core & Three-core Cables, Unarmoured With Copper Conductors	Page 37
6/10 kV Single-core & Three-core Cables, Tape Armoured With Copper Conductors	Page 41
6/10 kV Single-core & Three-core Cables, Wire Armoured With Copper Conductors	Page 45
6/10 kV Single-core & Three-core Cables, Unarmoured With Aluminum Conductors	Page 49
6/10 kV Single-core & Three-core Cables, Tape Armoured With Aluminum Conductors	Page 53
6/10 kV Single-core & Three-core Cables, Wire Armoured With Aluminum Conductors	Page 57
8.7/15 kV Single-core & Three-core Cables, Unarmoured With Copper Conductors	Page 61
8.7/15 kV Single-core & Three-core Cables, Tape Armoured With Copper Conductors	Page 65
8.7/15 kV Single-core & Three-core Cables, Wire Armoured With Copper Conductors	Page 69
8.7/15 kV Single-core & Three-core Cables, Unarmoured With Aluminum Conductors	Page 73
8.7/15 kV Single-core & Three-core Cables, Tape Armoured With Aluminum Conductors	Page 77
8.7/15 kV Single-core & Three-core Cables, Wire Armoured With Aluminum Conductors	Page 81
12/20 kV Single-core & Three-core Cables, Unarmoured With Copper Conductors	Page 85
12/20 kV Single-core & Three-core Cables, Tape Armoured With Copper Conductors	Page 89
12/20 kV Single-core & Three-core Cables, Wire Armoured With Copper Conductors	Page 93
12/20 kV Single-core & Three-core Cables, Unarmoured With Aluminum Conductors	Page 97
12/20 kV Single-core & Three-core Cables, Tape Armoured With Aluminum Conductors	Page 101
12/20 kV Single-core & Three-core Cables, Wire Armoured With Aluminum Conductors	Page 105

..... Continued

Index

Medium Voltage Cables

18/30 kV Single-core & Three-core Cables, Unarmoured With Copper Conductors	Page 109
18/30 kV Single-core & Three-core Cables, Tape Armoured With Copper Conductors	Page 113
18/30 kV Single-core & Three-core Cables, Wire Armoured With Copper Conductors	Page 117
18/30 kV Single-core & Three-core Cables, Unarmoured With Aluminum Conductors	Page 121
18/30 kV Single-core & Three-core Cables, Tape Armoured With Aluminum Conductors	Page 125
18/30 kV Single-core & Three-core Cables, Wire Armoured With Aluminum Conductors	Page 129

3 Cables For Special Applications

Lead Sheathed Cables	Page 133
Low Smoke Halogen Free Cables	Page 133
Other Types / Characteristics	Page 134

4 Technical Data

Annex A : Continuous Current Ratings	Page 135
Annex B : Recommendations	Page 138
Annex C : Tests	Page 142
Annex D : Formulas	Page 143
Annex E : Derating Factors	Page 145
Annex F : Short Circuit Current	Page 154
Annex G : Materials Properties	Page 156
Annex H : Coding Key	Page 157
Annex I : Information And Agreements	Page 158
Annex J : Conversion Table	Page 159

5 Product Range

6 Contact Us

The **alfanar** Medium Voltage Power and Special Application Cables are used in various indoor and outdoor applications in industries, switchboards and power stations.

Our products conform to various IEC and BS standards. They are tested at leading laboratories and are approved by many utility companies, ministries and major industries.

alfanar brand is the manifestation of **alfanar**'s constant endeavor for providing a comprehensive range of construction materials to satisfy its customers with products of the highest quality standard and safety, coupled with prompt services.

Our cables factory is one of the major industrial units in the ultramodern, fully-integrated **alfanar** Industrial Complex.



Industries

alfanar Industrial Complex – located in Riyadh – houses several industrial units for manufacturing medium/low voltage products, wires and cables, transformers, wooden reels (for coiling cables) and PVC compounds (for insulation and jacketing materials).

Apart from the manufacturing units, the Industrial Complex also houses a commercial zone, a data/communication center and other facilities.

The Industrial Complex is symbolic of **alfanar**'s consistent growth representing its bright future.

Group Overview

From its headquarters in Riyadh, Saudi Arabia, **alfanar** operates a fully-integrated global network of manufacturing facilities, design & development centers, and branches in Dubai (UAE), Doha (Qatar), Cairo (Egypt), Damascus (Syria), Chennai (India) and many other countries.

Our major businesses and services include: Electrical Manufacturing, Electrical Construction, Marketing and Distribution, Building Industry, Real Estate Development, Information Technology and Communication.

General Information

Selecting a Power Cable

The following factors are important when selecting a suitable cable construction which is required to transport electrical energy from the power station to the consumer:

- Maximum operating voltage
- Insulation level
- Frequency
- Load to be carried
- Magnitude and duration of possible load
- Mode of installation, either underground or in air
- Chemical and physical properties of soil
- Maximum and minimum ambient air temperature and soil temperature
- Specification and requirements to be met

Standards

The cables described in this catalogue are all standard types, and their performance has been proved in operation. Construction and tests are in accordance with the recommendations of IEC or BS publications where applicable. Power cables in accordance with other standards (VDE, NEMA or ICEA) can be manufactured upon a customer's request.

Weights and Dimensions

Weights and dimensions characteristics are approximate and any deviations are due to manufacturing tolerance.

Jacket Marking

Standard embossed outer jacket marking consisting of:

1. Name of manufacturer **alfanar**
2. Type designation, size of conductor, rated voltage
3. "ELECTRIC CABLE"
4. Year of manufacture
5. Continuous length marking every meter
6. Any special part number, on request

Definitions

Definitions of Dimensional Values

1. Nominal value

A value by which a quantity is designed and which is often used in tables; usually, in IEC standard, nominal values give rise to values to be checked by measurements taking into consideration the specified tolerances

2. Approximate value

A value which is neither guaranteed nor checked; it is used, for example, for the calculation of other dimensional values

3. Median value

When several test results have been obtained and sorted in an ascending or descending order, the median value is the middle value if the number of available values is odd, and the mean of the two middle values if the number of available values is even

4. Fictitious value

Value calculated according to the “fictitious method” described in Annex A of IEC 60502-2 or Annex E of BS 6622 (where applicable)

Definitions Concerning Tests

1. Routine tests

Tests made by the manufacturer on each manufactured length of cable to check that each length meets the specified requirements

2. Sample tests

Tests made by the manufacturer on samples of completed cable or components taken from a completed cable, at a specified frequency, so as to verify that the finished product meets the specified requirements

3. Type tests

Tests made before supplying on a general commercial basis, a type of cable covered by this standard, in order to demonstrate satisfactory performance characteristics to meet the intended application. These tests are of such a nature that, after they have been made, they need not be repeated, unless changes are made to the cable materials or to the design or manufacturing process, which might change the performance characteristics

4. Electrical tests after installation

Tests made to demonstrate the integrity of the cable and its accessories after installation

Introduction to XLPE Insulated Cables

XLPE Insulated Cables

XLPE Insulated cables have been used for distribution in public supply systems for about 25 years now. Because of their numerous advantages they have steadily displaced the classical Paper-Insulated cables in many countries.

XLPE is an abbreviation of Cross-linked polyethylene. This has been recognized worldwide as an excellent dielectric for wires and cables. It first went into commercial production in 1960. Polyethylene, which is a thermoplastic material, is converted into a thermosetting material by a process similar to vulcanization of rubber. By cross-linking, the linear chain structure of polyethylene is changed into three-dimensional network structure. By this change, polyethylene, which has outstanding dielectric properties, is made resistant to extremes of temperature.

The high resistance to heat deformation and ageing in hot air provide important advantage in cable ratings and is of special significance at locations where the ambient temperature is high. These, along with better resistance to environmental stress cracking and low dielectric constant make XLPE Cables particularly suitable for medium voltage applications.

Advantages of XLPE Insulation

High Continuous Current Ratings:

Higher continuous operating temperature of 90 °C for conductor permits XLPE Cables to withstand higher current ratings than PVC or PILC Cables.

High Short Circuit Ratings:

Maximum allowable continuous temperature during short circuit is 250 °C, which is vastly increased as compared to PVC or PILC Cables.

Little Deformation at High Temperature:

Under combined heat and mechanical pressure XLPE suffers less deformation compared to other solid dielectrics.

High Emergency Load Capacity:

XLPE cables can be operated at 130 °C during emergency. This should not exceed 1500 hours during the lifetime of a cable. Due to this, 20% higher current than the specific rating may be carried for this period.

Low Dielectric Loss:

The dielectric loss angle of XLPE is much lower than conventional dielectric. The dielectric losses are quadratically dependent on the voltage. Hence use of XLPE Cables at higher voltages would generate considerable saving in costs.

Low Charging Currents:

The charging currents are considerably lower than other dielectrics. This permits close setting of protection relays.

Lighter Weight:

XLPE Cable is easier to handle because of its light weight. Its small bending radius enables very easy laying and installation.

Rated Temp.	- Normal	90 °C
	- Emergency	130 °C
	- Short circuit	250 °C
Minimum tensile strength		12.5 N / mm ²
Minimum elongation at break		200 %
Relative permittivity (Dielectric constant)		2.5
Thermal resistivity		3.5 °C.m / W
Specific gravity		0.93 g / cm ³
Dielectric power factor at max. conductor temperature (tan δ)		40 x 10 ⁻⁴
Heat deformation at 150 °C		Good
Solvent resistance		Good
Splicing & termination		Easy
Environmental stress cracking		Good

Processing of XLPE Insulation

Cross-linked polyethylene via organic peroxide has emerged as the dominant process technology employed throughout the world for medium voltage cables. The choice of the cross-link additives and the stabilizer has a significant influence on the short and long term performance of medium voltage cables as well as the extrusion characteristics of the insulation compounds.

Cross-linked polyethylene is obtained through a first order reaction of high molecular polyethylene with the thermally driven homolytic cleavage of the peroxide bond (Fig. 1).



Where

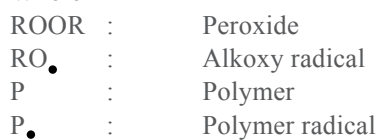

Fig. 1: Peroxide Cross-linking Reaction Sequence in Polyethylene

Introduction to XLPE Insulated Cables

The modern manufacturing process for XLPE insulation consists of triple extrusion of peroxide-cross-linkable polymeric cable component layer on a copper or aluminum conductor, followed by a continuous vulcanization process and a cooling step. The peroxide containing polymer compounds are extruded in the range of 110 °C to 140 °C at various line speeds, followed by vulcanization under 100~200 psi of dry hot nitrogen in a tube with a residence time to obtain the desired cross-linking of the compounds. The temperature is the key factor to induce decomposition of the peroxide, which initiates the cross-linking process in the polymer compounds. Therefore, the cross-linking condition is very sensitive to the heat transfer condition of the continuous vulcanization (CV) tube and cable construction.

The quality of the vulcanizable insulation compounds is strongly dependent on the efficiency of an organic peroxide concentration level. It is very important to understand the cure kinetics to define a proper cross-linking performance in the commercial CV tube conditions for optimum cable manufacturing process.

One of the critical elements in the processing of XLPE insulation for medium voltage cables is the perfection of the interfaces between the insulation and the semi-conductive inner and outer shields forming the three layers of insulation. This concern rises up the importance of the simultaneous extrusion of the inner semi-conductive, insulation and outer semi-conductive layers, which is achieved by the specially developed high performance triple heads using super smooth, extra clean raw materials with immediate curing on the continuous vulcanization (CV) line.

The one step continuous process guarantees the following features:

- Homogenous insulation, free from micro-voids
 - Very smooth interfaces between the insulation and the semi-conductive layers
 - High impulse and AC breakdown strength
 - Long life and service reliability
- Fig. 2 Continuous Vulcanization (CV) Line



Fig. 2 Continuous Vulcanization (CV) Line



Fig. 3 Triple-Head Extrusion System

Design of Medium Voltage Cables

Design Features

Medium voltage cables have common design features independent of the rated voltage and operating frequency. The components that essentially determine the electrical and thermal behavior of the cable are the conductor, the insulation with inner and outer semi-conductive layers and the metallic screen.

Medium voltage cables of rated voltages from 6 kV up to 30 kV (rated voltage of 35 kV is defined and included in some countries, like in Saudi Arabia) are designed as so-called Radial Field Cables.

The main XLPE insulation of a medium voltage cable can be regarded as a homogenous cylinder. Its field distribution or voltage gradient is therefore represented by a homogenous radial field. The value of the voltage gradient at a point x within the insulation can therefore be calculated as:

$$E_x = \frac{U_o}{r_x \cdot \ln\left(\frac{r_a}{r_i}\right)} \quad (\text{kV/mm})$$

Where

U_o	:	Operating voltage (kV).
r_x	:	Radius at position x.
r_a	:	External radius over insulation.
r_i	:	Radius of the inner semi-conductive layer

Note: All dimensions are in mm.

The electrical field strength is maximum at the inner semi-conductive layer and minimum above the insulation (below the outer semi-conductive layer, where $r_x = r_a$).

To ensure a defined cylindrical field and to withstand the field strength that occur, all medium voltage cables of rated voltages 6 kV and above, independent of their type of dielectric, require field limiting or field smoothing layers, widely known as semi-conductive layers, in the interface between conductor and insulation (**Conductor screen**) and between insulation and metallic screen (**Insulation screen**). These semi-conductive layers have two principal purposes:

1. Equalizing and reduction of the electrical stress in the cable dielectric by preventing local field enhancement in non-homogenous areas such as the individual wires of the conductor. The semi-conductive layers eliminate the effect of the individual wires on the field distribution (see Fig. 5).
2. Prevention of the formation of gaps or voids between the voltage-carrying components of the cable (conductor and metallic screen) and the insulation layer due to mechanical stress, e.g. bending of the cable or differential expansion of the various materials under varying thermal stress. A solid and permanent bond between the semi-conductive layers and the insulation effectively prevents the occurrence of partial discharges; an essential feature in the case of polymer-insulated cables.

The grounded metallic screen, which is always needed, provides effective electrical screening of the cable. The cable environment is thus free of electrical fields.

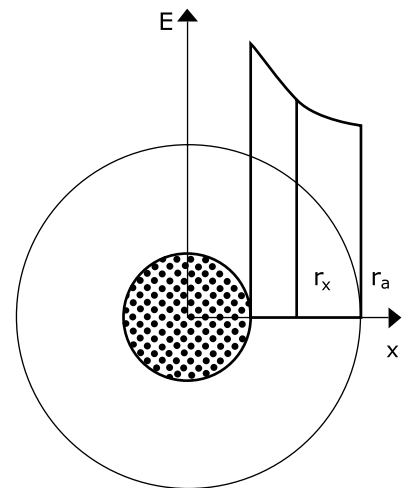
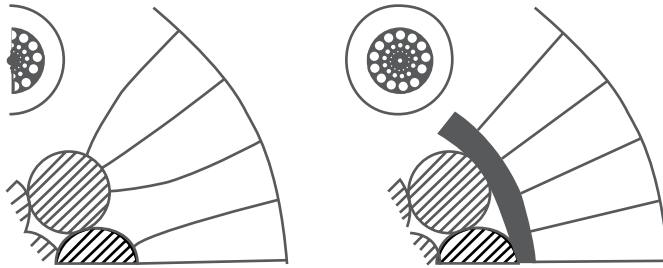

Fig. 4:
Field distribution within a medium voltage XLPE cable

Design of Medium Voltage Cables

The cable is finally given an overall sheath of suitable thermoplastic material to protect the metallic screen along with the complete cable from moisture and corrosion damages.



Without conductor screen:
Stress enhancement by small
radius of single wires

With conductor screen:
Cylindrical field distribution
(radial field)

Fig. 5:
Principle of field equalization over stranded conductor by using a conductive layer.

Construction of Medium Voltage Cables

XLPE Insulated Cables

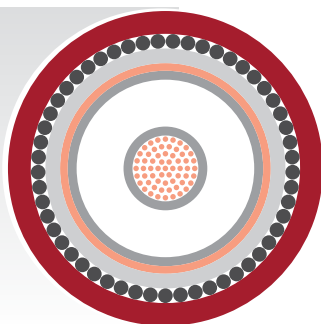

Components

The principle components of the common types of medium voltage cables have already been examined briefly under the heading “design features”. The most important properties and the function of these components will now be described in so far as they apply in general to the types of cables being covered by this catalogue.

These principle components described here below represent our standard models of cables, however any other models as for the customer’s standard are also available.

Conductor

The task of the conductor is to transmit the current with the lowest possible losses. The decisive properties for this function result in the first place from the conductor material and design. The conductor also plays a decisive part in the mechanical tensile strength and bending ability of a cable.

The conductor material shall be either of plain annealed copper or plain aluminum. The most important properties of the two conductor materials are compared here below.

Properties of Al and Cu conductor materials:

Property	Copper	Aluminum
Density in g/cm ³	8.89	2.703
Spec. resistance in $\Omega \cdot \text{mm}^2/\text{m}$	0.017241	0.028264
Tensile strength in N/mm ²	200 ... 300	70 ... 90

Construction of Medium Voltage Cables

The conductor behavior is characterized by two particularly noteworthy phenomena: the skin effect and the proximity effect.

The skin effect is the concentration of electric current flow around the periphery of the conductors.

It increases in proportion to the cross-section of conductor used.

The proximity effect is generated from the short distance separating the phases in the same circuit. When the conductor diameter is relatively large in relation to the distance separating the three phases, the electric current tends to concentrate on the surface facing the conductors. The wires of the facing surfaces indeed have a lower inductance than wires that are further away (the inductance of a circuit increases in proportion to the surface carried by the circuit). The current tends to circulate in the wires with the lowest inductance. In practice, the proximity effect is weaker than the skin effect and rapidly diminishes when the cables are moved away from each other.

The proximity effect is negligible when the distance between two single core cables in the same circuit or in two adjacent circuits is at least 8 times the outside diameter of the cable conductor.

There are two designs of conductor, stranded compacted circular conductors and stranded segmental (Milliken) conductors.

Compacted round conductors are composed of several layers of concentric spiral-wounded wires. Due to the low resistance electrical contacts between the wires in the compacted round stranded conductors, the skin and proximity effects are virtually identical to those of solid plain conductor. This structure is reserved for cross-sections up to and including 800 mm².

Segmental conductors, also known as “Milliken” conductors, are composed of several segment-shaped conductors assembled together to form a cylindrical core. This structure is reserved for large cross-sections of 1000 mm² and above. The “Milliken” type structure reduces the highly unfavorable skin and proximity effects.

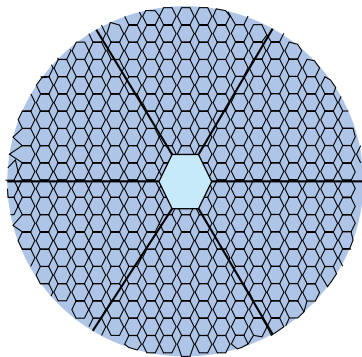

Segmental “Milliken” conductor

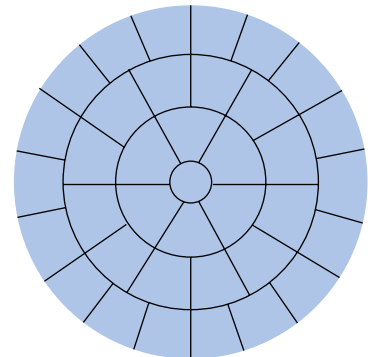

Compacted round stranded conductor

Fig. 6: Conductor designs for medium voltage cables

Conductor Screen

Conductor screen of an extruded semi-conducting compound shall be applied over the conductor to prevent the electric field concentration in the interface between the XLPE insulation and the conductor.

Insulation

As its name suggests, the insulation insulates the conductor when working at a certain voltage from the screen working at earthing potential. The insulation must be able to withstand the electric field under rated and transient operating conditions. The insulation for medium voltage cables shall be dry-cured XLPE compound with a thickness to meet dimensional, electrical and physical requirements specified by the design standard such as IEC, BS, ICEA, etc.

The compound shall be high quality and heat, moisture, ozone and corona resistant. The insulation shall be suitable for operation in wet or dry locations at conductor temperature not exceeding 90 °C for normal conditions, 130 °C for emergency overload conditions and 250 °C for short circuit conditions.

Insulation Screen

This layer has the same function as the conductor screen, where it is a progressive transition from an insulating medium, where the electric field is non-null, to a conductive medium (the cable metallic screen) in which the electric field is null.

The insulation screen shall be applied direct upon the insulation and shall consist of an extruded semi-conducting compound. The extruded semi-conducting compound can be firmly bonded to the insulation or easily strippable from the insulation. The volume resistivity of the extruded semi-conducting screens applied over the conductor (conductor screen) and over the insulation (insulation screen) shall not exceed 1000 $\Omega\cdot\text{m}$ and 500 $\Omega\cdot\text{m}$, respectively

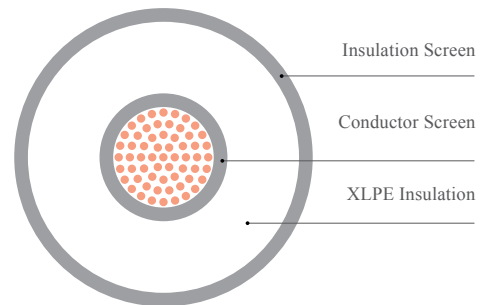

Fig. 7:
Conductor screen, XLPE insulation and insulation screen of medium voltage cable.

Construction of Medium Voltage Cables

Metallic Screen

When the voltage reaches tens or even hundreds of kV, a metallic screen is necessary. Its main function is to nullify the electric field outside the cable. In addition to the task of electrostatic screening already mentioned, the metallic screening also has to fulfill the following functions:

- Return of the capacitive charging current under operating conditions.
- Conduction of the earth fault current in case of a fault until the system is switched off.
- Reduction of the electrical influence on the cable surroundings in case of an earth fault.
- Provision of protection against accidental contact.

The metallic screen in medium voltage cables shall consist of one or more tapes, or a concentric layer of wires or a combination of wires and tape(s). When choosing the material of the screen - which is normally of copper – special consideration shall be given to the possibility of corrosion, not only for mechanical safety but also for electrical safety.

Armour

The armour protects the cable against mechanical stresses. For multi-core cables, galvanized steel is used as an armour material in one of the following forms:

1. Wires: Single layer applied concentrically over the bedding. Wire armour is recommended for cables which will be subjected to a horizontal mechanical stresses.
2. Tapes: Two tapes applied helically over extruded bedding in two layers so that the outer tape is approximately central over the gap of the inner tape. The gap between the adjacent turns of each tape shall not exceed 50 % of the width of the tape. Tape armour is recommended for cables which will be subjected to a vertical mechanical stresses.

Single core cables in single or three-phase AC (alternating current) systems are not armoured as a rule, in order to avoid additional losses. However, armour of non-magnetic material (aluminum) has to be provided wherever mechanical damage or higher tensile stresses are to be expected during or after laying the cable.

Anti-Corrosion Protective Jacket

Metallic screen or other metal sheaths require additional protection against mechanical damage and, above all, against corrosion caused by water in conjunction with electrolytically active components in the soil. The outer jacket must withstand the mechanical stresses encountered during installation and service, as well other risks such as termites, hydrocarbons, etc. It shall consist of thermoplastic compound (PVC, PE or similar materials) extruded continuously over the metallic layer.

Single-Core Cables, with Copper Conductors, XLPE Insulated and PVC Sheathed

APPLICATION

Suitable for installations indoors: mostly in power supply stations and outdoors: in cable ducts, underground, and on cable trays for industries, switch-boards and power stations.

APPLICABLE STANDARDS

alfanar medium voltage cables are designed and tested to meet or exceed the requirements of IEC 60502-2 standard. However, **alfanar** can also supply a range of alternative designs to meet customer-specified requirements.

CABLE CONSTRUCTION

Conductor

Plain annealed stranded circular compacted copper conductor (Class 2).

Conductor Screen

Extruded layer of a cross-linkable semi-conducting compound as a stress control layer.

Insulation

Extruded layer of cross-linked polyethylene (XLPE).

Insulation Screen

Extruded layer of a cross-linkable semi-conducting compound firmly bonded to the insulation.

Metallic Screen

Flat plain copper tape helically applied over the insulation screen with suitable overlap.

Outer Jacket

Extruded layer of Polyvinyl chloride (PVC).

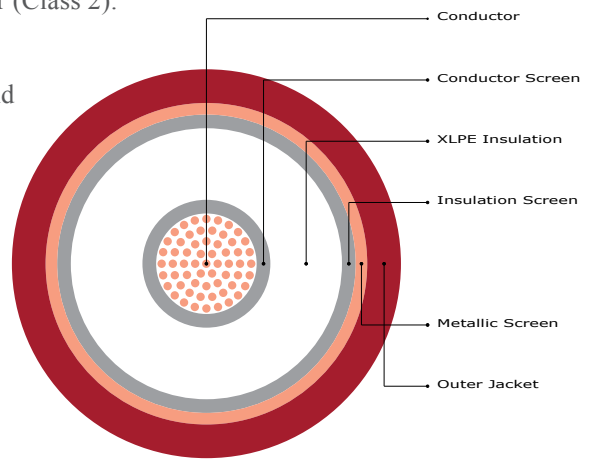

Note: The conductor screen, XLPE insulation and the insulation screen are extruded simultaneously in one process using triple extrusion method (Continuous Vulcanization Line). Triple extrusion method not only assures clean interfaces between the insulation and stress control layers, but also assures a construction free of Partial Discharge with high operational reliability.

TECHNICAL DATA

Rated voltage $U_0 / U (U_m)$	3.6 / 6 (7.2)	kV
Impulse test voltage (peak value)	60	kV
Power frequency test voltage for 5 minutes	12.5	kV
Max. conductor operating temperature at Normal conditions	90	°C
Max. conductor operating temperature at Emergency conditions	130	°C
Max. conductor operating temperature at Short circuit conditions	250	°C
Min. bending radius during installation in terms of cable outer diameter	20 Ø	

The above data is approximate and subject to manufacturing tolerance.

We reserve the right to change the above figures as a result of product development and/or changes in standard.

Constructional Data

Conductor		Insulation			Screen	Armour	Packing			Cable Code
Nominal area of conductor	Approx. conductor diameter	Thickness of insulation layers			Approx. metallic screen tape thickness	N / A	Approx. overall diameter	Approx. overall weight	Standard cutting length ± 5 %	
		C.S	XLPE	I.S						
mm ²	mm	Min.	Nom.	Min.	mm	mm	mm	kg / km	m	
25	5.85	0.3	2.5	0.3	0.076	-	16.2	467	1000	C316XF1BB0MRDXXI0MR
35	6.90	0.3	2.5	0.3	0.076	-	17.2	572	1000	C317XF1BB0MRDXXI0MR
50	8.10	0.3	2.5	0.3	0.076	-	18.6	720	1000	C318XF1BB0MRDXXI0MR
70	9.70	0.3	2.5	0.3	0.076	-	20.2	935	1000	C319XF1BB0MRDXXI0MR
95	11.30	0.3	2.5	0.3	0.076	-	22.0	1205	1000	C345XF1BB0MRDXXI0MR
120	12.60	0.3	2.5	0.3	0.076	-	23.3	1461	1000	C346XF1BB0MRDXXI0MR
150	14.10	0.3	2.5	0.3	0.076	-	25.0	1731	1000	C347XF1BB0MRDXXI0MR
185	15.80	0.3	2.5	0.3	0.076	-	26.7	2116	1000	C348XF1BB0MRDXXI0MR
240	18.10	0.3	2.6	0.3	0.076	-	29.4	2692	1000	C349XF1BB0MRDXXI0MR
300	20.50	0.3	2.8	0.3	0.076	-	32.4	3330	1000	C350XF1BB0MRDXXI0MR
400	23.10	0.3	3.0	0.3	0.076	-	35.6	4194	1000	C351XF1BB0MRDXXI0MR
500	26.50	0.3	3.2	0.3	0.076	-	39.6	5367	500	C352XF1BB0MRDXXI0MF
630	30.05	0.3	3.2	0.3	0.076	-	43.4	6665	500	C353XF1BB0MRDXXI0MF
800	34.00	0.3	3.2	0.3	0.076	-	47.9	8514	500	C354XF1BB0MRDXXI0MF
1000	40.00	0.3	3.2	0.3	0.076	-	55.5	10712	500	C755XF1BB0MRDXXI0MF

Electrical Data

Nominal area of conductor	Electrical Characteristics					Continuous Current Ratings						
	Max. Conductor Resistance		Reactance (60 Hz)	Impedance (90 °C, 60 Hz)	Capacitance	Buried direct in the ground		In single-way ducts		In air		
	DC at 20 °C	AC at 90 °C				Trefoil	Flat spaced	Trefoil	Flat touched	Trefoil	Flat touched	Flat spaced
	mm ²	Ω / km	Ω / km	Ω / km	Ω / km	μF / km	Fig. (a)	Fig. (b)	Fig. (c)	Fig. (d)	Fig. (e)	Fig. (f)
25	0.7270	0.9272	0.153	0.940	0.255	126	132	114	114	140	143	170
35	0.5240	0.6685	0.145	0.684	0.283	151	157	137	137	170	174	207
50	0.3870	0.4939	0.136	0.512	0.317	178	185	162	162	204	209	249
70	0.2680	0.3424	0.128	0.366	0.362	217	226	198	198	255	262	311
95	0.1930	0.2471	0.123	0.276	0.407	259	269	238	237	311	319	380
120	0.1530	0.1965	0.119	0.230	0.444	293	304	270	269	359	368	436
150	0.1240	0.1599	0.116	0.198	0.486	327	340	303	301	409	419	497
185	0.0991	0.1287	0.112	0.170	0.533	368	382	343	340	470	481	569
240	0.0754	0.0993	0.109	0.147	0.577	425	439	397	393	556	568	669
300	0.0601	0.0807	0.107	0.134	0.600	476	491	448	441	638	651	767
400	0.0470	0.0651	0.104	0.123	0.625	535	550	508	497	735	747	878
500	0.0366	0.0532	0.102	0.115	0.664	599	612	573	557	846	856	1007
630	0.0283	0.0442	0.099	0.109	0.742	664	675	643	618	963	969	1140
800	0.0221	0.0378	0.097	0.105	0.831	725	733	709	676	1081	1080	1271
1000	0.0176	0.0250	0.094	0.098	0.992	891	829	842	782	1387	1359	1503

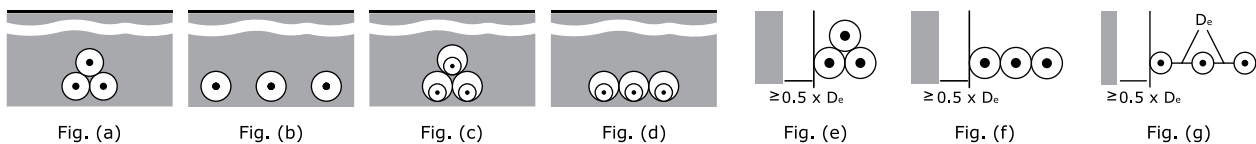

Laying Conditions: Ambient air temperature of 40 °C, Ambient ground temperature of 30 °C, Soil thermal resistivity of 1.5 K·m/W, Depth of laying of 0.8 m. and cable screens are bonded at both ends. In case of different laying conditions, appropriate correction (derating) factors from Annex E have to be applied to cater for the actual installation conditions.

Three-Core Cables, with Copper Conductors, XLPE Insulated and PVC Sheathed

APPLICATION

Suitable for installations indoors: mostly in power supply stations and outdoors: in cable ducts, underground, and on cable trays for industries, switch-boards and power stations.

APPLICABLE STANDARDS

alfanar medium voltage cables are designed and tested to meet or exceed the requirements of IEC 60502-2 standard. However, **alfanar** can also supply a range of alternative designs to meet customer-specified requirements.

CABLE CONSTRUCTION

Conductor

Plain annealed stranded circular compacted copper conductor (Class 2).

Conductor Screen

Extruded layer of a cross-linkable semi-conducting compound as a stress control layer.

Insulation

Extruded layer of cross-linked polyethylene (XLPE).

Insulation Screen

Extruded layer of a cross-linkable semi-conducting compound firmly bonded to the insulation.

Metallic Screen

Flat plain copper tape helically applied over the insulation screen with suitable overlap.

Filler

Non-hygroscopic polypropylene filler suitable for the cable's operating temperature.

Outer Jacket

Extruded layer of Polyvinyl chloride (PVC).

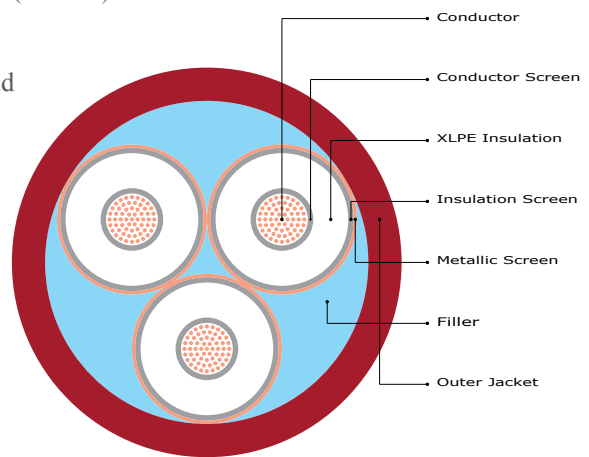

Note: The conductor screen, XLPE insulation and the insulation screen are extruded simultaneously in one process using triple extrusion method (Continuous Vulcanization Line). Triple extrusion method not only assures clean interfaces between the insulation and stress control layers, but also assures a construction free of Partial Discharge with high operational reliability.

TECHNICAL DATA

Rated voltage $U_0 / U (U_m)$	3.6 / 6 (7.2)	kV
Impulse test voltage (peak value)	60	kV
Power frequency test voltage for 5 minutes	12.5	kV
Max. conductor operating temperature at Normal conditions	90	°C
Max. conductor operating temperature at Emergency conditions	130	°C
Max. conductor operating temperature at Short circuit conditions	250	°C
Min. bending radius during installation in terms of cable outer diameter	15 Ø	

The above data is approximate and subject to manufacturing tolerance.

We reserve the right to change the above figures as a result of product development and/or changes in standard.

Constructional Data

Conductor		Insulation			Screen	Armour	Packing			Cable Code
Nominal area of conductor	Approx. conductor diameter	Thickness of insulation layers			Approx. metallic screen tape thickness	N / A	Approx. overall diameter	Approx. overall weight	Standard cutting length $\pm 5\%$	
		C.S	XLPE	I.S						
mm ²	mm	Min.	Nom.	Min.	mm	mm	mm	kg / km	m	
25	5.85	0.3	2.5	0.3	0.076	-	33.2	1507	1000	C316XF3BB0MRDXXI0MR
35	6.90	0.3	2.5	0.3	0.076	-	35.4	1844	1000	C317XF3BB0MRDXXI0MR
50	8.10	0.3	2.5	0.3	0.076	-	38.2	2301	1000	C318XF3BB0MRDXXI0MR
70	9.70	0.3	2.5	0.3	0.076	-	42.0	3018	1000	C319XF3BB0MRDXXI0MR
95	11.30	0.3	2.5	0.3	0.076	-	45.7	3857	1000	C345XF3BB0MRDXXI0MR
120	12.60	0.3	2.5	0.3	0.076	-	48.7	4679	1000	C346XF3BB0MRDXXI0MR
150	14.10	0.3	2.5	0.3	0.076	-	52.1	5522	1000	C347XF3BB0MRDXXI0MR
185	15.80	0.3	2.5	0.3	0.076	-	56.0	6754	500	C348XF3BB0MRDXXI0MF
240	18.10	0.3	2.6	0.3	0.076	-	61.8	8585	500	C349XF3BB0MRDXXI0MF
300	20.50	0.3	2.8	0.3	0.076	-	68.2	10620	500	C350XF3BB0MRDXXI0MF
400	23.10	0.3	3.0	0.3	0.076	-	75.1	13361	500	C351XF3BB0MRDXXI0MF

Electrical Data

Nominal area of conductor	Electrical Characteristics					Continuous Current Ratings		
	Max. Conductor Resistance		Reactance (60 Hz)	Impedance (90 °C, 60 Hz)	Capacitance	Buried direct in the ground	In a buried duct	In air
	DC at 20 °C	AC at 90 °C				Fig. (a)	Fig. (b)	Fig. (c)
mm ²	Ω / km	Ω / km	Ω / km	Ω / km	$\mu\text{F} / \text{km}$	A	A	A
25	0.7270	0.9272	0.141	0.938	0.255	128	106	141
35	0.5240	0.6685	0.133	0.682	0.283	152	127	171
50	0.3870	0.4940	0.124	0.509	0.317	179	151	204
70	0.2680	0.3426	0.118	0.362	0.362	218	185	254
95	0.1930	0.2474	0.113	0.272	0.407	260	222	309
120	0.1530	0.1968	0.110	0.225	0.444	294	253	355
150	0.1240	0.1603	0.107	0.193	0.486	329	284	403
185	0.0991	0.1292	0.103	0.165	0.533	371	322	462
240	0.0754	0.1000	0.100	0.142	0.577	426	374	542
300	0.0601	0.0815	0.099	0.128	0.600	478	422	619
400	0.0470	0.0661	0.097	0.117	0.625	536	477	708

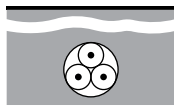

Fig. (a)

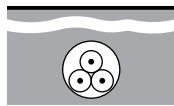

Fig. (b)



Fig. (c)

Laying Conditions: Ambient air temperature of 40 °C, Ambient ground temperature of 30 °C, Soil thermal resistivity of 1.5 K·m/W, Depth of laying of 0.8 m, and cable screens are bonded at both ends. In case of different laying conditions, appropriate correction (derating) factors from *Annex E* have to be applied to cater for the actual installation conditions.

Single-Core Cables, with Copper Conductors, XLPE Insulated, Tape Armoured and PVC Sheathed

APPLICATION

Suitable for installations indoors: mostly in power supply stations and outdoors: in cable ducts, underground, and on cable trays for industries, switch-boards and power stations. Due to the good laying and mechanical characteristics, this cable is suitable when mechanical protection is required or in applications where mechanical damages are expected to occur.

APPLICABLE STANDARDS

alfanar medium voltage cables are designed and tested to meet or exceed the requirements of IEC 60502-2 standard. However, **alfanar** can also supply a range of alternative designs to meet customer-specified requirements.

CABLE CONSTRUCTION

Conductor

Plain annealed stranded circular compacted copper conductor (Class 2).

Conductor Screen

Extruded layer of a cross-linkable semi-conducting compound as a stress control layer.

Insulation

Extruded layer of cross-linked polyethylene (XLPE).

Insulation Screen

Extruded layer of a cross-linkable semi-conducting compound firmly bonded to the insulation.

Metallic Screen

Flat plain copper tape helically applied over the insulation screen with suitable overlap.

Bedding

Extruded layer of Polyvinyl chloride (PVC).

Armouring

Double layer of non-magnetic (aluminum) tapes.

Outer Jacket

Extruded layer of Polyvinyl chloride (PVC).

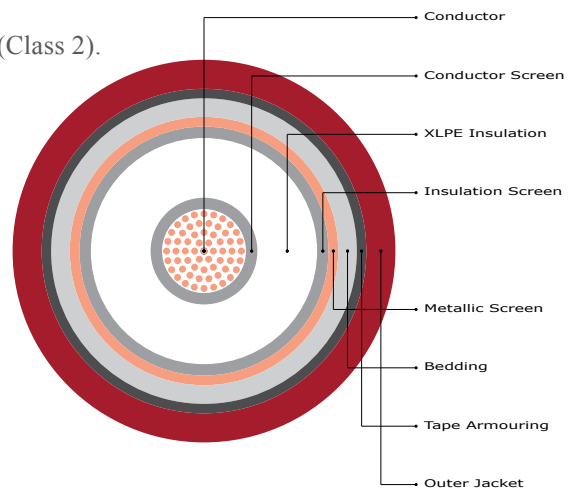

Note: The conductor screen, XLPE insulation and the insulation screen are extruded simultaneously in one process using triple extrusion method (Continuous Vulcanization Line). Triple extrusion method not only assures clean interfaces between the insulation and stress control layers, but also assures a construction free of Partial Discharge with high operational reliability.

TECHNICAL DATA

Rated voltage $U_0 / U (U_m)$	3.6 / 6 (7.2)	kV
Impulse test voltage (peak value)	60	kV
Power frequency test voltage for 5 minutes	12.5	kV
Max. conductor operating temperature at Normal conditions	90	°C
Max. conductor operating temperature at Emergency conditions	130	°C
Max. conductor operating temperature at Short circuit conditions	250	°C
Min. bending radius during installation in terms of cable outer diameter	15 Ø	

The above data is approximate and subject to manufacturing tolerance.

We reserve the right to change the above figures as a result of product development and/or changes in standard.

Constructional Data

Conductor		Insulation			Screen	Armour	Packing			Cable Code
Nominal area of conductor	Approx. conductor diameter	Thickness of insulation layers			Approx. metallic screen tape thickness	Tape thickness	Approx. overall diameter	Approx. overall weight	Standard cutting length $\pm 5\%$	
		C.S.	XLPE	I.S.						
mm ²	mm	Min.	Nom.	Min.	mm	mm	mm	kg / km	m	
25	5.85	0.3	2.5	0.3	0.076	0.50	20.8	691	1000	C316XF1BBBMRDXXI0MR
35	6.90	0.3	2.5	0.3	0.076	0.50	22.0	818	1000	C317XF1BBBMRDXXI0MR
50	8.10	0.3	2.5	0.3	0.076	0.50	23.2	973	1000	C318XF1BBBMRDXXI0MR
70	9.70	0.3	2.5	0.3	0.076	0.50	25.0	1220	1000	C319XF1BBBMRDXXI0MR
95	11.30	0.3	2.5	0.3	0.076	0.50	26.6	1500	1000	C345XF1BBBMRDXXI0MR
120	12.60	0.3	2.5	0.3	0.076	0.50	28.1	1784	1000	C346XF1BBBMRDXXI0MR
150	14.10	0.3	2.5	0.3	0.076	0.50	29.6	2061	1000	C347XF1BBBMRDXXI0MR
185	15.80	0.3	2.5	0.3	0.076	0.50	31.5	2482	1000	C348XF1BBBMRDXXI0MR
240	18.10	0.3	2.6	0.3	0.076	0.50	34.2	3093	1000	C349XF1BBBMRDXXI0MR
300	20.50	0.3	2.8	0.3	0.076	0.50	37.2	3769	1000	C350XF1BBBMRDXXI0MR
400	23.10	0.3	3.0	0.3	0.076	0.50	40.4	4674	1000	C351XF1BBBMRDXXI0MR
500	26.50	0.3	3.2	0.3	0.076	0.50	44.6	5919	500	C352XF1BBBMRDXXI0MF
630	30.05	0.3	3.2	0.3	0.076	0.50	48.6	7290	500	C353XF1BBBMRDXXI0MF
800	34.00	0.3	3.2	0.3	0.076	0.50	52.9	9175	500	C354XF1BBBMRDXXI0MF
1000	40.00	0.3	3.2	0.3	0.076	0.50	60.9	11532	500	C755XF1BBBMRDXXI0MF

Electrical Data

Nominal area of conductor	Electrical Characteristics					Continuous Current Ratings						
	Max. Conductor Resistance		Reactance (60 Hz)	Impedance (90 °C, 60 Hz)	Capacitance	Buried direct in the ground		In single-way ducts		In air		
	DC at 20 °C	AC at 90 °C				Trefoil	Flat spaced	Trefoil	Flat touched	Trefoil	Flat touched	Flat spaced
	mm ²	Ω / km	Ω / km	Ω / km	Ω / km	$\mu\text{F} / \text{km}$	Fig. (a)	Fig. (b)	Fig. (c)	Fig. (d)	Fig. (e)	Fig. (f)
25	0.7270	0.9272	0.172	0.943	0.255	127	132	116	116	144	147	171
35	0.5240	0.6684	0.164	0.688	0.283	151	157	139	139	175	178	207
50	0.3870	0.4938	0.152	0.517	0.317	178	184	164	163	209	214	248
70	0.2680	0.3423	0.145	0.372	0.362	217	224	200	199	261	266	308
95	0.1930	0.2470	0.138	0.283	0.407	258	265	239	237	317	323	373
120	0.1530	0.1962	0.134	0.237	0.444	291	298	271	267	364	370	426
150	0.1240	0.1596	0.129	0.205	0.486	326	331	303	298	414	420	482
185	0.0991	0.1283	0.124	0.179	0.533	366	369	341	334	474	480	548
240	0.0754	0.0988	0.120	0.156	0.577	421	419	393	381	558	562	639
300	0.0601	0.0801	0.117	0.142	0.600	473	464	441	425	639	640	723
400	0.0470	0.0644	0.114	0.131	0.625	530	513	496	473	733	730	817
500	0.0366	0.0523	0.111	0.123	0.664	592	564	556	524	841	830	924
630	0.0283	0.0432	0.108	0.116	0.742	652	597	610	562	949	921	1006
800	0.0221	0.0367	0.105	0.111	0.831	705	622	657	591	1054	1005	1080
1000	0.0176	0.0247	0.101	0.104	0.992	831	662	743	643	1296	1188	1201

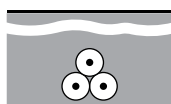

Fig. (a)

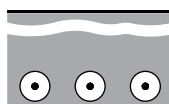

Fig. (b)

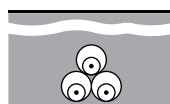

Fig. (c)

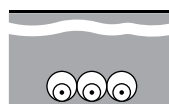

Fig. (d)

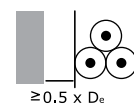

Fig. (e)

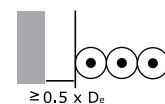

Fig. (f)

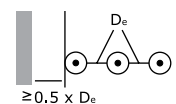

Fig. (g)

Laying Conditions: Ambient air temperature of 40 °C, Ambient ground temperature of 30 °C, Soil thermal resistivity of 1.5 K·m/W, Depth of laying of 0.8 m, and cable screens are bonded at both ends. In case of different laying conditions, appropriate correction (derating) factors from *Annex E* have to be applied to cater for the actual installation conditions.

Three-Core Cables, with Copper Conductors, XLPE Insulated, Tape Armoured and PVC Sheathed

APPLICATION

Suitable for installations indoors: mostly in power supply stations and outdoors: in cable ducts, underground, and on cable trays for industries, switch-boards and power stations. Due to the good laying and mechanical characteristics, this cable is suitable when mechanical protection is required or in applications where mechanical damages are expected to occur.

APPLICABLE STANDARDS

alfanar medium voltage cables are designed and tested to meet or exceed the requirements of IEC 60502-2 standard. However, **alfanar** can also supply a range of alternative designs to meet customer-specified requirements.

CABLE CONSTRUCTION

Conductor

Plain annealed stranded circular compacted copper conductor (Class 2).

Conductor Screen

Extruded layer of a cross-linkable semi-conducting compound as a stress control layer.

Insulation

Extruded layer of cross-linked polyethylene (XLPE).

Insulation Screen

Extruded layer of a cross-linkable semi-conducting compound firmly bonded to the insulation.

Metallic Screen

Flat plain copper tape helically applied over the insulation screen with suitable overlap.

Filler

Non-hygroscopic polypropylene filler suitable for the cable's operating temperature.

Bedding

Extruded layer of Polyvinyl chloride (PVC).

Armouring

Double layer of galvanized steel tapes.

Outer Jacket

Extruded layer of Polyvinyl chloride (PVC).

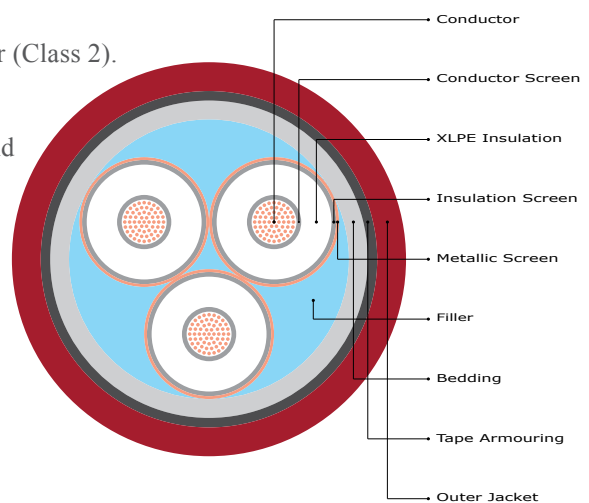

Note: The conductor screen, XLPE insulation and the insulation screen are extruded simultaneously in one process using triple extrusion method (Continuous Vulcanization Line). Triple extrusion method not only assures clean interfaces between the insulation and stress control layers, but also assures a construction free of Partial Discharge with high operational reliability.

TECHNICAL DATA

Rated voltage $U_0 / U (U_m)$	3.6 / 6 (7.2)	kV
Impulse test voltage (peak value)	60	kV
Power frequency test voltage for 5 minutes	12.5	kV
Max. conductor operating temperature at Normal conditions	90	°C
Max. conductor operating temperature at Emergency conditions	130	°C
Max. conductor operating temperature at Short circuit conditions	250	°C
Min. bending radius during installation in terms of cable outer diameter	15 \emptyset	

Constructional Data

Conductor		Insulation			Screen	Armour	Packing			Cable Code
Nominal area of conductor	Approx. conductor diameter	Thickness of insulation layers			Approx. metallic screen tape thickness	Tape thickness	Approx. overall diameter	Approx. overall weight	Standard cutting length $\pm 5\%$	
		C.S.	XLPE	I.S.						
mm ²	mm	Min.	Nom.	Min.	mm	mm	mm	kg / km	m	
25	5.85	0.3	2.5	0.3	0.076	0.50	37.8	2286	1000	C316XF3BBGMRDXXI0MR
35	6.90	0.3	2.5	0.3	0.076	0.50	40.4	2716	1000	C317XF3BBGMRDXXI0MR
50	8.10	0.3	2.5	0.3	0.076	0.50	43.2	3237	1000	C318XF3BBGMRDXXI0MR
70	9.70	0.3	2.5	0.3	0.076	0.50	47.0	4042	1000	C319XF3BBGMRDXXI0MR
95	11.30	0.3	2.5	0.3	0.076	0.50	50.7	4967	1000	C345XF3BBGMRDXXI0MR
120	12.60	0.3	2.5	0.3	0.076	0.50	54.1	5915	500	C346XF3BBGMRDXXI0MF
150	14.10	0.3	2.5	0.3	0.076	0.50	57.7	6871	500	C347XF3BBGMRDXXI0MF
185	15.80	0.3	2.5	0.3	0.076	0.50	61.6	8200	500	C348XF3BBGMRDXXI0MF
240	18.10	0.3	2.6	0.3	0.076	0.50	67.6	10209	500	C349XF3BBGMRDXXI0MF
300	20.50	0.3	2.8	0.3	0.076	0.50	74.2	12444	400	C350XF3BBGMRDXXI0MU
400	23.10	0.3	3.0	0.3	0.076	0.80	82.9	16251	400	C351XF3BBGMRDXXI0MU

Electrical Data

Nominal area of conductor	Electrical Characteristics					Continuous Current Ratings		
	Max. Conductor Resistance		Reactance (60 Hz)	Impedance (90 °C, 60 Hz)	Capacitance	Buried direct in the ground	In a buried duct	In air
	DC at 20 °C	AC at 90 °C				Fig. (a)	Fig. (b)	Fig. (c)
mm ²	Ω / km	Ω / km	Ω / km	Ω / km	$\mu\text{F} / \text{km}$	A	A	A
25	0.7270	0.9272	0.141	0.938	0.255	122	104	132
35	0.5240	0.6685	0.133	0.682	0.283	146	125	160
50	0.3870	0.4940	0.124	0.509	0.317	171	147	190
70	0.2680	0.3426	0.118	0.362	0.362	208	180	235
95	0.1930	0.2474	0.113	0.272	0.407	248	216	285
120	0.1530	0.1968	0.110	0.225	0.444	280	245	325
150	0.1240	0.1603	0.107	0.193	0.486	313	276	369
185	0.0991	0.1292	0.103	0.165	0.533	352	312	419
240	0.0754	0.1000	0.100	0.142	0.577	404	360	489
300	0.0601	0.0815	0.099	0.128	0.600	451	405	555
400	0.0470	0.0661	0.097	0.117	0.625	506	458	633

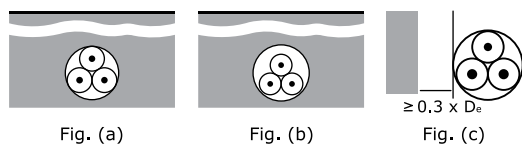

Laying Conditions: Ambient air temperature of 40 °C, Ambient ground temperature of 30 °C, Soil thermal resistivity of 1.5 K·m/W, Depth of laying of 0.8 m. and cable screens are bonded at both ends. In case of different laying conditions, appropriate correction (derating) factors from *Annex E* have to be applied to cater for the actual installation conditions.

Single-Core Cables, with Copper Conductors, XLPE Insulated, Wire Armoured and PVC Sheathed

APPLICATION

Suitable for installations indoors: mostly in power supply stations and outdoors: in cable ducts, underground, and on cable trays for industries, switch-boards and power stations. Due to the good laying and mechanical characteristics, this cable is suitable when mechanical protection is required or in applications where mechanical damages are expected to occur.

APPLICABLE STANDARDS

alfanar medium voltage cables are designed and tested to meet or exceed the requirements of IEC 60502-2 standard and/or BS 6622 standard with rated voltage 3.8 / 6.6 (7.2) kV. However, **alfanar** can also supply a range of alternative designs to meet customer-specified requirements.

CABLE CONSTRUCTION

Conductor

Plain annealed stranded circular compacted copper conductor (Class 2).

Conductor Screen

Extruded layer of a cross-linkable semi-conducting compound as a stress control layer.

Insulation

Extruded layer of cross-linked polyethylene (XLPE).

Insulation Screen

Extruded layer of a cross-linkable semi-conducting compound firmly bonded to the insulation.

Metallic Screen

Flat plain copper tape helically applied over the insulation screen with suitable overlap.

Bedding

Extruded layer of Polyvinyl chloride (PVC).

Armouring

Single layer of round non-magnetic (aluminum) wires.

Outer Jacket

Extruded layer of Polyvinyl chloride (PVC).

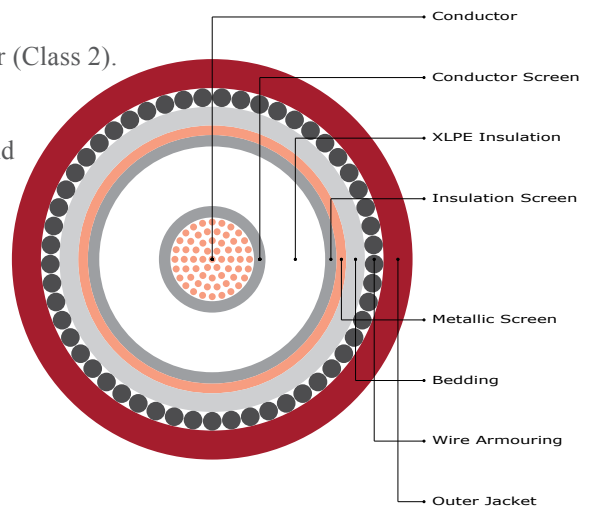

Note: The conductor screen, XLPE insulation and the insulation screen are extruded simultaneously in one process using triple extrusion method (Continuous Vulcanization Line). Triple extrusion method not only assures clean interfaces between the insulation and stress control layers, but also assures a construction free of Partial Discharge with high operational reliability.

TECHNICAL DATA

Rated voltage $U_0 / U (U_m)$	3.6 / 6 (7.2)	kV
Impulse test voltage (peak value)	60	kV
Power frequency test voltage for 5 minutes	12.5	kV
Max. conductor operating temperature at Normal conditions	90	°C
Max. conductor operating temperature at Emergency conditions	130	°C
Max. conductor operating temperature at Short circuit conditions	250	°C
Min. bending radius during installation in terms of cable outer diameter	15 Ø	

The above data is approximate and subject to manufacturing tolerance.

We reserve the right to change the above figures as a result of product development and/or changes in standard.

Constructional Data

Conductor		Insulation			Screen	Armour	Packing			Cable Code
Nominal area of conductor	Approx. conductor diameter	Thickness of insulation layers			Approx. metallic screen tape thickness	Wire diameter	Approx. overall diameter	Approx. overall weight	Standard cutting length $\pm 5\%$	
		C.S	XLPE	I.S						
mm ²	mm	Min.	Nom.	Min.	mm	mm	mm	kg / km	m	
25	5.85	0.3	2.5	0.3	0.076	1.60	22.7	799	1000	C316XF1BBAMRDXXI0MR
35	6.90	0.3	2.5	0.3	0.076	1.60	23.7	922	1000	C317XF1BBAMRDXXI0MR
50	8.10	0.3	2.5	0.3	0.076	1.60	25.1	1094	1000	C318XF1BBAMRDXXI0MR
70	9.70	0.3	2.5	0.3	0.076	1.60	26.7	1338	1000	C319XF1BBAMRDXXI0MR
95	11.30	0.3	2.5	0.3	0.076	1.60	28.5	1640	1000	C345XF1BBAMRDXXI0MR
120	12.60	0.3	2.5	0.3	0.076	1.60	29.8	1916	1000	C346XF1BBAMRDXXI0MR
150	14.10	0.3	2.5	0.3	0.076	1.60	31.5	2218	1000	C347XF1BBAMRDXXI0MR
185	15.80	0.3	2.5	0.3	0.076	2.00	34.2	2733	1000	C348XF1BBAMRDXXI0MR
240	18.10	0.3	2.6	0.3	0.076	2.00	36.7	3342	1000	C349XF1BBAMRDXXI0MR
300	20.50	0.3	2.8	0.3	0.076	2.00	39.7	4039	1000	C350XF1BBAMRDXXI0MR
400	23.10	0.3	3.0	0.3	0.076	2.00	42.9	4973	1000	C351XF1BBAMRDXXI0MR
500	26.50	0.3	3.2	0.3	0.076	2.50	48.3	6425	500	C352XF1BBAMRDXXI0MF
630	30.05	0.3	3.2	0.3	0.076	2.50	52.3	7835	500	C353XF1BBAMRDXXI0MF
800	34.00	0.3	3.2	0.3	0.076	2.50	56.6	9772	500	C354XF1BBAMRDXXI0MF
1000	40.00	0.3	3.2	0.3	0.076	2.50	64.6	12208	500	C755XF1BBAMRDXXI0MF

Electrical Data

Nominal area of conductor	Electrical Characteristics					Continuous Current Ratings						
	Max. Conductor Resistance		Reactance (60 Hz)	Impedance (90 °C, 60 Hz)	Capacitance	Buried direct in the ground		In single-way ducts		In air		
	DC at 20 °C	AC at 90 °C				Trefoil	Flat spaced	Trefoil	Flat touched	Trefoil	Flat touched	Flat spaced
	mm ²	Ω / km	Ω / km	Ω / km	Ω / km	$\mu\text{F} / \text{km}$	Fig. (a)	Fig. (b)	Fig. (c)	Fig. (d)	Fig. (e)	Fig. (f)
25	0.7270	0.9272	0.179	0.944	0.255	127	131	118	116	148	150	173
35	0.5240	0.6684	0.170	0.690	0.283	152	155	140	138	179	182	208
50	0.3870	0.4938	0.158	0.519	0.317	178	180	164	161	214	217	247
70	0.2680	0.3423	0.149	0.373	0.362	216	214	198	193	265	267	303
95	0.1930	0.2469	0.143	0.285	0.407	256	249	234	225	320	320	361
120	0.1530	0.1962	0.138	0.240	0.444	286	270	260	246	366	361	402
150	0.1240	0.1595	0.134	0.208	0.486	317	292	286	268	413	403	446
185	0.0991	0.1282	0.130	0.183	0.533	353	317	316	293	469	453	495
240	0.0754	0.0986	0.125	0.160	0.577	399	346	353	321	542	514	555
300	0.0601	0.0798	0.122	0.146	0.600	439	369	385	345	611	571	608
400	0.0470	0.0641	0.118	0.135	0.625	473	388	410	362	679	618	661
500	0.0366	0.0519	0.117	0.128	0.664	513	411	442	386	757	676	722
630	0.0283	0.0426	0.113	0.121	0.742	551	434	472	409	835	733	782
800	0.0221	0.0361	0.110	0.116	0.831	583	456	499	429	907	784	841
1000	0.0176	0.0246	0.106	0.109	0.992	626	493	540	465	1022	876	947

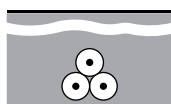

Fig. (a)

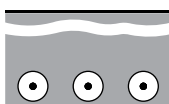

Fig. (b)

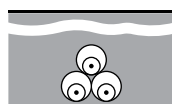

Fig. (c)

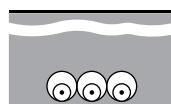

Fig. (d)

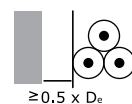

Fig. (e)

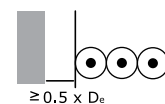

Fig. (f)

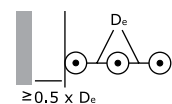

Fig. (g)

Laying Conditions: Ambient air temperature of 40 °C, Ambient ground temperature of 30 °C, Soil thermal resistivity of 1.5 K·m/W, Depth of laying of 0.8 m, and cable screens are bonded at both ends. In case of different laying conditions, appropriate correction (derating) factors from *Annex E* have to be applied to cater for the actual installation conditions.

Three-Core Cables, with Copper Conductors, XLPE Insulated, Wire Armoured and PVC Sheathed

APPLICATION

Suitable for installations indoors: mostly in power supply stations and outdoors: in cable ducts, underground, and on cable trays for industries, switch-boards and power stations. Due to the good laying and mechanical characteristics, this cable is suitable when mechanical protection is required or in applications where mechanical damages are expected to occur.

APPLICABLE STANDARDS

alfanar medium voltage cables are designed and tested to meet or exceed the requirements of IEC 60502-2 standard and/or BS 6622 standard with rated voltage 3.8 / 6.6 (7.2) kV. However, **alfanar** can also supply a range of alternative designs to meet customer-specified requirements.

CABLE CONSTRUCTION

Conductor

Plain annealed stranded circular compacted copper conductor (Class 2).

Conductor Screen

Extruded layer of a cross-linkable semi-conducting compound as a stress control layer.

Insulation

Extruded layer of cross-linked polyethylene (XLPE).

Insulation Screen

Extruded layer of a cross-linkable semi-conducting compound firmly bonded to the insulation.

Metallic Screen

Flat plain copper tape helically applied over the insulation screen with suitable overlap.

Filler

Non-hygroscopic polypropylene filler suitable for the cable's operating temperature.

Bedding

Extruded layer of Polyvinyl chloride (PVC).

Armouring

Single layer of round galvanized steel wires.

Outer Jacket

Extruded layer of Polyvinyl chloride (PVC).

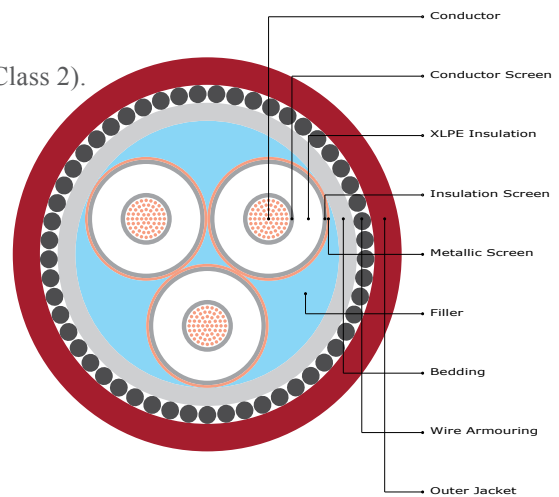

Note: The conductor screen, XLPE insulation and the insulation screen are extruded simultaneously in one process using triple extrusion method (Continuous Vulcanization Line). Triple extrusion method not only assures clean interfaces between the insulation and stress control layers, but also assures a construction free of Partial Discharge with high operational reliability.

TECHNICAL DATA

Rated voltage $U_0 / U (U_m)$	3.6 / 6 (7.2)	kV
Impulse test voltage (peak value)	60	kV
Power frequency test voltage for 5 minutes	12.5	kV
Max. conductor operating temperature at Normal conditions	90	°C
Max. conductor operating temperature at Emergency conditions	130	°C
Max. conductor operating temperature at Short circuit conditions	250	°C
Min. bending radius during installation in terms of cable outer diameter	12 \emptyset	

Constructional Data

Conductor		Insulation			Screen	Armour	Packing			Cable Code
Nominal area of conductor	Approx. conductor diameter	Thickness of insulation layers			Approx. metallic screen tape thickness	Wire diameter	Approx. overall diameter	Approx. overall weight	Standard cutting length $\pm 5\%$	
		C.S.	XLPE	I.S.						
mm ²	mm	Min.	Nom.	Min.	mm	mm	mm	kg / km	m	
25	5.85	0.3	2.5	0.3	0.076	2.00	40.0	3079	1000	C316XF3BBWMDXXI0MR
35	6.90	0.3	2.5	0.3	0.076	2.50	43.6	3952	1000	C317XF3BBWMDXXI0MR
50	8.10	0.3	2.5	0.3	0.076	2.50	46.4	4560	1000	C318XF3BBWMDXXI0MR
70	9.70	0.3	2.5	0.3	0.076	2.50	50.2	5479	1000	C319XF3BBWMDXXI0MR
95	11.30	0.3	2.5	0.3	0.076	2.50	53.9	6521	500	C345XF3BBWMDXXI0MF
120	12.60	0.3	2.5	0.3	0.076	2.50	57.3	7554	500	C346XF3BBWMDXXI0MF
150	14.10	0.3	2.5	0.3	0.076	2.50	60.9	8626	500	C347XF3BBWMDXXI0MF
185	15.80	0.3	2.5	0.3	0.076	2.50	64.8	10069	500	C348XF3BBWMDXXI0MF
240	18.10	0.3	2.6	0.3	0.076	2.50	70.8	12287	500	C349XF3BBWMDXXI0MF
300	20.50	0.3	2.8	0.3	0.076	3.15	79.3	15768	400	C350XF3BBWMDXXI0MU
400	23.10	0.3	3.0	0.3	0.076	3.15	86.8	19124	350	C351XF3BBWMDXXI0MV

Electrical Data

Nominal area of conductor	Electrical Characteristics					Continuous Current Ratings		
	Max. Conductor Resistance		Reactance (60 Hz)	Impedance (90 °C, 60 Hz)	Capacitance	Buried direct in the ground	In a buried duct	In air
	DC at 20 °C	AC at 90 °C				Fig. (a)	Fig. (b)	Fig. (c)
mm ²	Ω / km	Ω / km	Ω / km	Ω / km	$\mu\text{F} / \text{km}$	A	A	A
25	0.7270	0.9272	0.141	0.938	0.255	123	106	135
35	0.5240	0.6685	0.133	0.682	0.283	146	126	163
50	0.3870	0.4940	0.124	0.509	0.317	171	149	193
70	0.2680	0.3426	0.118	0.362	0.362	208	182	238
95	0.1930	0.2474	0.113	0.272	0.407	247	217	287
120	0.1530	0.1968	0.110	0.225	0.444	278	245	327
150	0.1240	0.1603	0.107	0.193	0.486	309	274	369
185	0.0991	0.1292	0.103	0.165	0.533	345	307	417
240	0.0754	0.1000	0.100	0.142	0.577	391	351	482
300	0.0601	0.0815	0.099	0.128	0.600	431	389	541
400	0.0470	0.0661	0.097	0.117	0.625	475	431	606

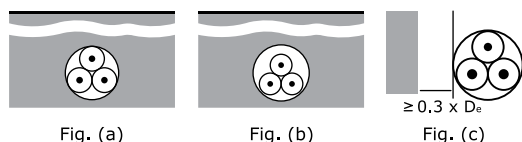

Fig. (a)

Fig. (b)

Fig. (c)

Laying Conditions: Ambient air temperature of 40 °C, Ambient ground temperature of 30 °C, Soil thermal resistivity of 1.5 K·m/W, Depth of laying of 0.8 m. and cable screens are bonded at both ends. In case of different laying conditions, appropriate correction (derating) factors from *Annex E* have to be applied to cater for the actual installation conditions.

Single-Core Cables, with Aluminum Conductors, XLPE Insulated and PVC Sheathed

APPLICATION

Suitable for installations indoors: mostly in power supply stations and outdoors: in cable ducts, underground, and on cable trays for industries, switch-boards and power stations.

APPLICABLE STANDARDS

alfanar medium voltage cables are designed and tested to meet or exceed the requirements of IEC 60502-2 standard. However, **alfanar** can also supply a range of alternative designs to meet customer-specified requirements.

CABLE CONSTRUCTION

Conductor

Stranded circular compacted aluminum conductor (Class 2).

Conductor Screen

Extruded layer of a cross-linkable semi-conducting compound as a stress control layer.

Insulation

Extruded layer of cross-linked polyethylene (XLPE).

Insulation Screen

Extruded layer of a cross-linkable semi-conducting compound firmly bonded to the insulation.

Metallic Screen

Flat plain copper tape helically applied over the insulation screen with suitable overlap.

Outer Jacket

Extruded layer of Polyvinyl chloride (PVC).

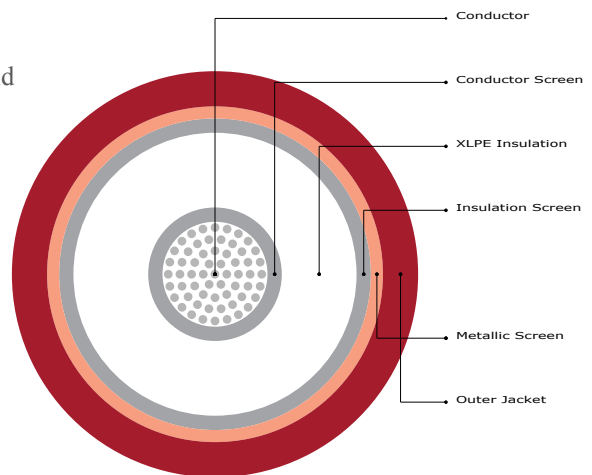

Note: The conductor screen, XLPE insulation and the insulation screen are extruded simultaneously in one process using triple extrusion method (Continuous Vulcanization Line). Triple extrusion method not only assures clean interfaces between the insulation and stress control layers, but also assures a construction free of Partial Discharge with high operational reliability.

TECHNICAL DATA

Rated voltage $U_0 / U (U_m)$	3.6 / 6 (7.2)	kV
Impulse test voltage (peak value)	60	kV
Power frequency test voltage for 5 minutes	12.5	kV
Max. conductor operating temperature at Normal conditions	90	°C
Max. conductor operating temperature at Emergency conditions	130	°C
Max. conductor operating temperature at Short circuit conditions	250	°C
Min. bending radius during installation in terms of cable outer diameter	20 Ø	

The above data is approximate and subject to manufacturing tolerance.

We reserve the right to change the above figures as a result of product development and/or changes in standard.

Constructional Data

Conductor		Insulation			Screen	Armour	Packing			Cable Code
Nominal area of conductor	Approx. conductor diameter	Thickness of insulation layers			Approx. metallic screen tape thickness	N / A	Approx. overall diameter	Approx. overall weight	Standard cutting length $\pm 5\%$	
		C.S	XLPE	I.S						
mm ²	mm	Min.	Nom.	Min.	mm	mm	mm	kg / km	m	
25	5.85	0.3	2.5	0.3	0.076	-	33.2	1045	1000	A316XF3BB0MRDXXI0MR
35	6.90	0.3	2.5	0.3	0.076	-	35.4	1202	1000	A317XF3BB0MRDXXI0MR
50	8.10	0.3	2.5	0.3	0.076	-	38.2	1424	1000	A318XF3BB0MRDXXI0MR
70	9.70	0.3	2.5	0.3	0.076	-	42.0	1764	1000	A319XF3BB0MRDXXI0MR
95	11.30	0.3	2.5	0.3	0.076	-	45.7	2132	1000	A345XF3BB0MRDXXI0MR
120	12.60	0.3	2.5	0.3	0.076	-	48.7	2486	1000	A346XF3BB0MRDXXI0MR
150	14.10	0.3	2.5	0.3	0.076	-	52.1	2864	1000	A347XF3BB0MRDXXI0MR
185	15.80	0.3	2.5	0.3	0.076	-	56.0	3361	500	A348XF3BB0MRDXXI0MF
240	18.10	0.3	2.6	0.3	0.076	-	61.8	4154	500	A349XF3BB0MRDXXI0MF
300	20.50	0.3	2.8	0.3	0.076	-	68.2	5040	500	A350XF3BB0MRDXXI0MF
400	23.10	0.3	3.0	0.3	0.076	-	75.1	6191	500	A351XF3BB0MRDXXI0MF

Electrical Data

Nominal area of conductor	Electrical Characteristics					Continuous Current Ratings						
	Max. Conductor Resistance		Reactance (60 Hz)	Impedance (90 °C, 60 Hz)	Capacitance	Buried direct in the ground		In single-way ducts		In air		
	DC at 20 °C	AC at 90 °C				Trefoil	Flat spaced	Trefoil	Flat touched	Trefoil	Flat touched	Flat spaced
	mm ²	Ω / km	Ω / km	Ω / km	Ω / km	$\mu\text{F} / \text{km}$	A	A	A	A	A	A
25	1.2000	1.5386	0.153	1.546	0.255	98	102	89	89	108	111	132
35	0.8680	1.1130	0.145	1.122	0.283	117	122	106	106	132	135	161
50	0.6410	0.8221	0.136	0.833	0.317	138	144	126	125	158	162	194
70	0.4430	0.5684	0.128	0.583	0.362	168	176	154	154	198	203	242
95	0.3200	0.4109	0.123	0.429	0.407	201	210	184	184	242	248	295
120	0.2530	0.3252	0.119	0.346	0.444	228	237	210	209	279	286	340
150	0.2060	0.2652	0.116	0.290	0.486	254	266	236	235	318	326	387
185	0.1640	0.2117	0.112	0.239	0.533	287	300	268	267	367	376	446
240	0.1250	0.1622	0.109	0.195	0.577	333	346	311	309	435	446	527
300	0.1000	0.1307	0.107	0.169	0.600	375	389	352	349	503	514	606
400	0.0778	0.1031	0.104	0.147	0.625	427	441	403	398	586	598	703
500	0.0605	0.0819	0.102	0.131	0.664	485	499	461	453	685	697	818
630	0.0469	0.0658	0.099	0.119	0.742	547	560	525	511	793	804	941
800	0.0367	0.0541	0.097	0.112	0.831	610	620	590	570	908	916	1070
1000	0.0291	0.0389	0.094	0.102	0.992	728	703	692	657	1131	1127	1265

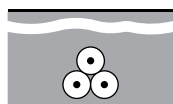

Fig. (a)

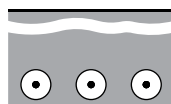

Fig. (b)

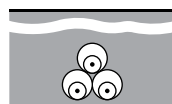

Fig. (c)

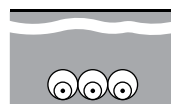

Fig. (d)

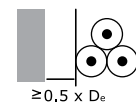

Fig. (e)

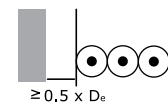

Fig. (f)

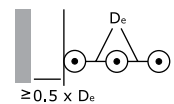

Fig. (g)

Laying Conditions: Ambient air temperature of 40 °C, Ambient ground temperature of 30 °C, Soil thermal resistivity of 1.5 K·m/W, Depth of laying of 0.8 m, and cable screens are bonded at both ends. In case of different laying conditions, appropriate correction (derating) factors from *Annex E* have to be applied to cater for the actual installation conditions.

Three-Core Cables, with Aluminum Conductors, XLPE Insulated and PVC Sheathed

APPLICATION

uitable for installations indoors: mostly in power supply stations and outdoors: in cable ducts, underground, and on cable trays for industries, switch-boards and power stations.

APPLICABLE STANDARDS

alfanar medium voltage cables are designed and tested to meet or exceed the requirements of IEC 60502-2 standard. However, **alfanar** can also supply a range of alternative designs to meet customer-specified requirements.

CABLE CONSTRUCTION

Conductor

Stranded circular compacted aluminum conductor (Class 2).

Conductor Screen

Extruded layer of a cross-linkable semi-conducting compound as a stress control layer.

Insulation

Extruded layer of cross-linked polyethylene (XLPE).

Insulation Screen

Extruded layer of a cross-linkable semi-conducting compound firmly bonded to the insulation.

Metallic Screen

Flat plain copper tape helically applied over the insulation screen with suitable overlap.

Outer Jacket

Extruded layer of Polyvinyl chloride (PVC).

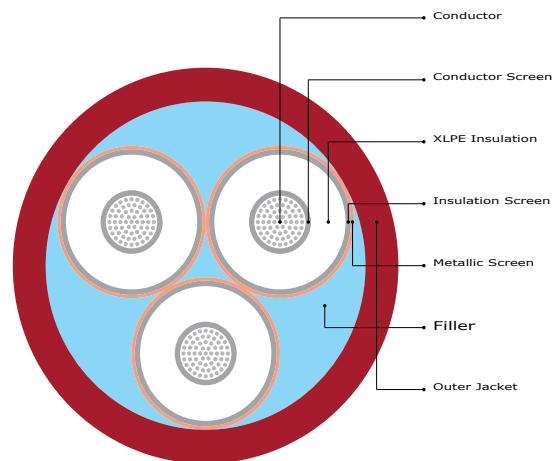

Note: The conductor screen, XLPE insulation and the insulation screen are extruded simultaneously in one process using triple extrusion method (Continuous Vulcanization Line). Triple extrusion method not only assures clean interfaces between the insulation and stress control layers, but also assures a construction free of Partial Discharge with high operational reliability.

TECHNICAL DATA

Rated voltage $U_0 / U (U_m)$	3.6 / 6 (7.2)	kV
Impulse test voltage (peak value)	60	kV
Power frequency test voltage for 5 minutes	12.5	kV
Max. conductor operating temperature at Normal conditions	90	°C
Max. conductor operating temperature at Emergency conditions	130	°C
Max. conductor operating temperature at Short circuit conditions	250	°C
Min. bending radius during installation in terms of cable outer diameter	15 Ø	

The above data is approximate and subject to manufacturing tolerance.

We reserve the right to change the above figures as a result of product development and/or changes in standard.

Constructional Data

Conductor		Insulation			Screen	Armour	Packing			Cable Code
Nominal area of conductor	Approx. conductor diameter	Thickness of insulation layers			Approx. metallic screen tape thickness	Wire diameter	Approx. overall diameter	Approx. overall weight	Standard cutting length $\pm 5\%$	
		C.S	XLPE	I.S						
mm ²	mm	Min.	Nom.	Min.	mm	mm	mm	kg / km	m	
25	5.85	0.3	2.5	0.3	0.076	2.00	40.0	3079	1000	C316XF3BBWMRDXXI0MR
35	6.90	0.3	2.5	0.3	0.076	2.50	43.6	3952	1000	C317XF3BBWMRDXXI0MR
50	8.10	0.3	2.5	0.3	0.076	2.50	46.4	4560	1000	C318XF3BBWMRDXXI0MR
70	9.70	0.3	2.5	0.3	0.076	2.50	50.2	5479	1000	C319XF3BBWMRDXXI0MR
95	11.30	0.3	2.5	0.3	0.076	2.50	53.9	6521	500	C345XF3BBWMRDXXI0MF
120	12.60	0.3	2.5	0.3	0.076	2.50	57.3	7554	500	C346XF3BBWMRDXXI0MF
150	14.10	0.3	2.5	0.3	0.076	2.50	60.9	8626	500	C347XF3BBWMRDXXI0MF
185	15.80	0.3	2.5	0.3	0.076	2.50	64.8	10069	500	C348XF3BBWMRDXXI0MF
240	18.10	0.3	2.6	0.3	0.076	2.50	70.8	12287	500	C349XF3BBWMRDXXI0MF
300	20.50	0.3	2.8	0.3	0.076	3.15	79.3	15768	400	C350XF3BBWMRDXXI0MU
400	23.10	0.3	3.0	0.3	0.076	3.15	86.8	19124	350	C351XF3BBWMRDXXI0MV

Electrical Data

Nominal area of conductor	Electrical Characteristics					Continuous Current Ratings		
	Max. Conductor Resistance		Reactance (60 Hz)	Impedance (90 °C, 60 Hz)	Capacitance	Buried direct in the ground	In a buried duct	In air
	DC at 20 °C	AC at 90 °C				Fig. (a)	Fig. (b)	Fig. (c)
mm ²	Ω / km	Ω / km	Ω / km	Ω / km	$\mu\text{F} / \text{km}$	A	A	A
25	0.7270	0.9272	0.141	0.938	0.255	123	106	135
35	0.5240	0.6685	0.133	0.682	0.283	146	126	163
50	0.3870	0.4940	0.124	0.509	0.317	171	149	193
70	0.2680	0.3426	0.118	0.362	0.362	208	182	238
95	0.1930	0.2474	0.113	0.272	0.407	247	217	287
120	0.1530	0.1968	0.110	0.225	0.444	278	245	327
150	0.1240	0.1603	0.107	0.193	0.486	309	274	369
185	0.0991	0.1292	0.103	0.165	0.533	345	307	417
240	0.0754	0.1000	0.100	0.142	0.577	391	351	482
300	0.0601	0.0815	0.099	0.128	0.600	431	389	541
400	0.0470	0.0661	0.097	0.117	0.625	475	431	606

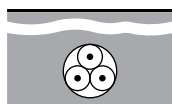

Fig. (a)

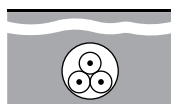

Fig. (b)



Fig. (c)

Laying Conditions: Ambient air temperature of 40 °C, Ambient ground temperature of 30 °C, Soil thermal resistivity of 1.5 K·m/W, Depth of laying of 0.8 m, and cable screens are bonded at both ends. In case of different laying conditions, appropriate correction (derating) factors from *Annex E* have to be applied to cater for the actual installation conditions.

Single-Core Cables, with Aluminum Conductors, XLPE Insulated, Tape Armoured and PVC Sheathed

APPLICATION

uitable for installations indoors: mostly in power supply stations and outdoors: in cable ducts, underground, and on cable trays for industries, switch-boards and power stations. Due to the good laying and mechanical characteristics, this cable is suitable when mechanical protection is required or in applications where mechanical damages are expected to occur.

APPLICABLE STANDARDS

alfanar medium voltage cables are designed and tested to meet or exceed the requirements of IEC 60502-2 standard. However, **alfanar** can also supply a range of alternative designs to meet customer-specified requirements.

CABLE CONSTRUCTION

Conductor

Stranded circular compacted aluminum conductor (Class 2).

Conductor Screen

Extruded layer of a cross-linkable semi-conducting compound as a stress control layer.

Insulation

Extruded layer of cross-linked polyethylene (XLPE).

Insulation Screen

Extruded layer of a cross-linkable semi-conducting compound firmly bonded to the insulation.

Metallic Screen

Flat plain copper tape helically applied over the insulation screen with suitable overlap.

Bedding

Extruded layer of Polyvinyl chloride (PVC).

Armouring

Double layer of non-magnetic (aluminum) tapes.

Outer Jacket

Extruded layer of Polyvinyl chloride (PVC).

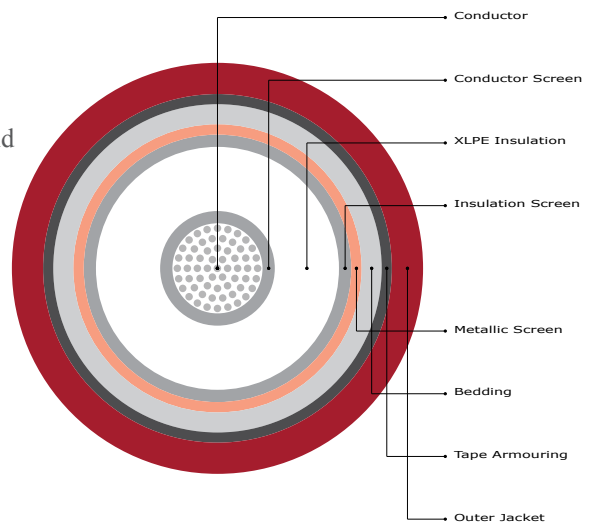

Note: The conductor screen, XLPE insulation and the insulation screen are extruded simultaneously in one process using triple extrusion method (Continuous Vulcanization Line). Triple extrusion method not only assures clean interfaces between the insulation and stress control layers, but also assures a construction free of Partial Discharge with high operational reliability.

TECHNICAL DATA

Rated voltage $U_0 / U (U_m)$	3.6 / 6 (7.2)	kV
Impulse test voltage (peak value)	60	kV
Power frequency test voltage for 5 minutes	12.5	kV
Max. conductor operating temperature at Normal conditions	90	°C
Max. conductor operating temperature at Emergency conditions	130	°C
Max. conductor operating temperature at Short circuit conditions	250	°C
Min. bending radius during installation in terms of cable outer diameter	15 Ø	

The above data is approximate and subject to manufacturing tolerance.

We reserve the right to change the above figures as a result of product development and/or changes in standard.

Constructional Data

Conductor		Insulation			Screen	Armour	Packing			Cable Code
Nominal area of conductor	Approx. conductor diameter	Thickness of insulation layers			Approx. metallic screen tape thickness	Tape thickness	Approx. overall diameter	Approx. overall weight	Standard cutting length $\pm 5\%$	
		C.S	XLPE	I.S						
mm ²	mm	Min.	Nom.	Min.	mm	mm	mm	kg / km	m	
25	5.85	0.3	2.5	0.3	0.076	0.50	20.8	537	1000	A316XF1BBBMRDXXI0MR
35	6.90	0.3	2.5	0.3	0.076	0.50	22.0	604	1000	A317XF1BBBMRDXXI0MR
50	8.10	0.3	2.5	0.3	0.076	0.50	23.2	681	1000	A318XF1BBBMRDXXI0MR
70	9.70	0.3	2.5	0.3	0.076	0.50	25.0	802	1000	A319XF1BBBMRDXXI0MR
95	11.30	0.3	2.5	0.3	0.076	0.50	26.6	925	1000	A345XF1BBBMRDXXI0MR
120	12.60	0.3	2.5	0.3	0.076	0.50	28.1	1053	1000	A346XF1BBBMRDXXI0MR
150	14.10	0.3	2.5	0.3	0.076	0.50	29.6	1175	1000	A347XF1BBBMRDXXI0MR
185	15.80	0.3	2.5	0.3	0.076	0.50	31.5	1351	1000	A348XF1BBBMRDXXI0MR
240	18.10	0.3	2.6	0.3	0.076	0.50	34.2	1616	1000	A349XF1BBBMRDXXI0MR
300	20.50	0.3	2.8	0.3	0.076	0.50	37.2	1909	1000	A350XF1BBBMRDXXI0MR
400	23.10	0.3	3.0	0.3	0.076	0.50	40.4	2284	1000	A351XF1BBBMRDXXI0MR
500	26.50	0.3	3.2	0.3	0.076	0.50	44.6	2789	1000	A352XF1BBBMRDXXI0MR
630	30.05	0.3	3.2	0.3	0.076	0.50	48.6	3354	1000	A353XF1BBBMRDXXI0MR
800	34.00	0.3	3.2	0.3	0.076	0.50	52.9	4075	500	A354XF1BBBMRDXXI0MF
1000	40.00	0.3	3.2	0.3	0.076	0.50	60.9	5077	500	A755XF1BBBMRDXXI0MF

Electrical Data

Nominal area of conductor	Electrical Characteristics					Continuous Current Ratings						
	Max. Conductor Resistance		Reactance (60 Hz)	Impedance (90 °C, 60 Hz)	Capacitance	Buried direct in the ground		In single-way ducts		In air		
	DC at 20 °C	AC at 90 °C				Trefoil	Flat spaced	Trefoil	Flat touched	Trefoil	Flat touched	Flat spaced
	mm ²	Ω / km	Ω / km	Ω / km	Ω / km	$\mu\text{F} / \text{km}$	A	A	A	A	A	A
25	1.2000	1.5386	0.172	1.548	0.255	98	103	90	91	112	114	133
35	0.8680	1.1130	0.164	1.125	0.283	117	122	108	108	135	139	161
50	0.6410	0.8220	0.152	0.836	0.317	138	143	128	127	163	166	193
70	0.4430	0.5683	0.145	0.586	0.362	168	175	156	156	203	207	241
95	0.3200	0.4108	0.138	0.433	0.407	201	208	187	185	246	252	292
120	0.2530	0.3251	0.134	0.351	0.444	227	235	212	210	284	290	335
150	0.2060	0.2650	0.129	0.295	0.486	254	261	237	235	323	329	380
185	0.1640	0.2115	0.124	0.245	0.533	287	294	269	265	371	378	435
240	0.1250	0.1619	0.120	0.202	0.577	331	337	311	305	439	445	510
300	0.1000	0.1303	0.117	0.175	0.600	374	376	350	342	505	511	582
400	0.0778	0.1026	0.114	0.153	0.625	424	422	399	387	586	590	668
500	0.0605	0.0813	0.111	0.137	0.664	481	472	454	436	682	683	768
630	0.0469	0.0650	0.108	0.126	0.742	540	513	508	479	785	775	858
800	0.0367	0.0533	0.105	0.118	0.831	597	549	560	517	891	867	944
1000	0.0291	0.0387	0.101	0.109	0.992	694	593	635	569	1078	1022	1063

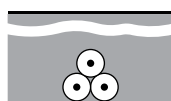

Fig. (a)

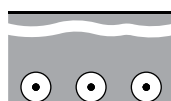

Fig. (b)

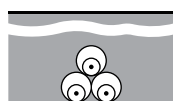

Fig. (c)

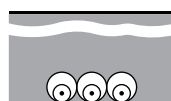

Fig. (d)

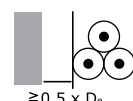

Fig. (e)

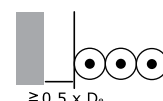

Fig. (f)

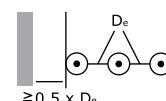

Fig. (g)

Laying Conditions: Ambient air temperature of 40 °C, Ambient ground temperature of 30 °C, Soil thermal resistivity of 1.5 K·m/W, Depth of laying of 0.8 m, and cable screens are bonded at both ends. In case of different laying conditions, appropriate correction (derating) factors from *Annex E* have to be applied to cater for the actual installation conditions.

Three-Core Cables, with Aluminum Conductors, XLPE Insulated, Tape Armoured and PVC Sheathed

APPLICATION

Suitable for installations indoors: mostly in power supply stations and outdoors: in cable ducts, underground, and on cable trays for industries, switch-boards and power stations. Due to the good laying and mechanical characteristics, this cable is suitable when mechanical protection is required or in applications where mechanical damages are expected to occur.

APPLICABLE STANDARDS

alfanar medium voltage cables are designed and tested to meet or exceed the requirements of IEC 60502-2 standard. However, **alfanar** can also supply a range of alternative designs to meet customer-specified requirements.

CABLE CONSTRUCTION

Conductor

Stranded circular compacted aluminum conductor (Class 2).

Conductor Screen

Extruded layer of a cross-linkable semi-conducting compound as a stress control layer.

Insulation

Extruded layer of cross-linked polyethylene (XLPE).

Insulation Screen

Extruded layer of a cross-linkable semi-conducting compound firmly bonded to the insulation.

Metallic Screen

Flat plain copper tape helically applied over the insulation screen with suitable overlap.

Filler

Non-hygroscopic polypropylene filler suitable for the cable's operating temperature.

Bedding

Extruded layer of Polyvinyl chloride (PVC).

Armouring

Double layer of galvanized steel tapes.

Outer Jacket

Extruded layer of Polyvinyl chloride (PVC).

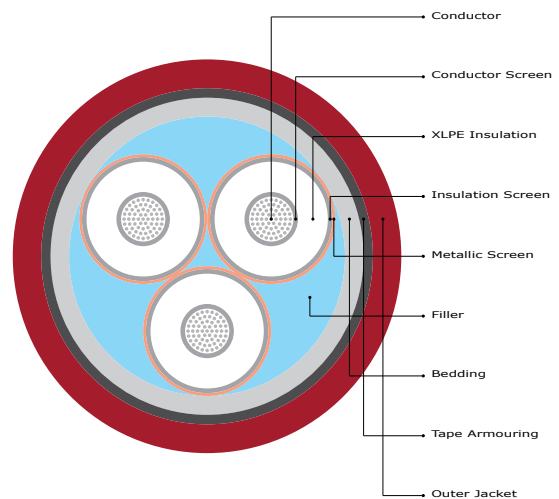

Note: The conductor screen, XLPE insulation and the insulation screen are extruded simultaneously in one process using triple extrusion method (Continuous Vulcanization Line). Triple extrusion method not only assures clean interfaces between the insulation and stress control layers, but also assures a construction free of Partial Discharge with high operational reliability.

TECHNICAL DATA

Rated voltage $U_0 / U (U_m)$	3.6 / 6 (7.2)	kV
Impulse test voltage (peak value)	60	kV
Power frequency test voltage for 5 minutes	12.5	kV
Max. conductor operating temperature at Normal conditions	90	°C
Max. conductor operating temperature at Emergency conditions	130	°C
Max. conductor operating temperature at Short circuit conditions	250	°C
Min. bending radius during installation in terms of cable outer diameter	12 Ø	

Constructional Data

Conductor		Insulation			Screen	Armour	Packing			Cable Code
Nominal area of conductor	Approx. conductor diameter	Thickness of insulation layers			Approx. metallic screen tape thickness	Tape thickness	Approx. overall diameter	Approx. overall weight	Standard cutting length $\pm 5\%$	
		C.S.	XLPE	I.S.						
mm ²	mm	Min.	Nom.	Min.	mm	mm	mm	kg / km	m	
25	5.85	0.3	2.5	0.3	0.076	0.50	37.8	1824	1000	A316XF3BBGMRDXXI0MR
35	6.90	0.3	2.5	0.3	0.076	0.50	40.4	2074	1000	A317XF3BBGMRDXXI0MR
50	8.10	0.3	2.5	0.3	0.076	0.50	43.2	2360	1000	A318XF3BBGMRDXXI0MR
70	9.70	0.3	2.5	0.3	0.076	0.50	47.0	2788	1000	A319XF3BBGMRDXXI0MR
95	11.30	0.3	2.5	0.3	0.076	0.50	50.7	3242	1000	A345XF3BBGMRDXXI0MR
120	12.60	0.3	2.5	0.3	0.076	0.50	54.1	3722	500	A346XF3BBGMRDXXI0MF
150	14.10	0.3	2.5	0.3	0.076	0.50	57.7	4213	500	A347XF3BBGMRDXXI0MF
185	15.80	0.3	2.5	0.3	0.076	0.50	61.6	4807	500	A348XF3BBGMRDXXI0MF
240	18.10	0.3	2.6	0.3	0.076	0.50	67.6	5778	500	A349XF3BBGMRDXXI0MF
300	20.50	0.3	2.8	0.3	0.076	0.50	74.2	6864	500	A350XF3BBGMRDXXI0MF
400	23.10	0.3	3.0	0.3	0.076	0.80	82.9	9081	400	A351XF3BBGMRDXXI0MU

Electrical Data

Nominal area of conductor	Electrical Characteristics					Continuous Current Ratings		
	Max. Conductor Resistance		Reactance (60 Hz)	Impedance (90 °C, 60 Hz)	Capacitance	Buried direct in the ground	In a buried duct	In air
	DC at 20 °C	AC at 90 °C				Fig. (a)	Fig. (b)	Fig. (c)
mm ²	Ω / km	Ω / km	Ω / km	Ω / km	$\mu\text{F} / \text{km}$	A	A	A
25	1.2000	1.5387	0.141	1.545	0.255	95	81	103
35	0.8680	1.1131	0.133	1.121	0.283	113	97	124
50	0.6410	0.8221	0.124	0.831	0.317	133	114	147
70	0.4430	0.5685	0.118	0.581	0.362	162	140	183
95	0.3200	0.4110	0.113	0.426	0.407	192	168	221
120	0.2530	0.3254	0.110	0.343	0.444	218	191	253
150	0.2060	0.2654	0.107	0.286	0.486	244	215	287
185	0.1640	0.2120	0.103	0.236	0.533	275	244	328
240	0.1250	0.1626	0.100	0.191	0.577	318	284	385
300	0.1000	0.1312	0.099	0.164	0.600	357	321	439
400	0.0778	0.1037	0.097	0.142	0.625	406	368	508

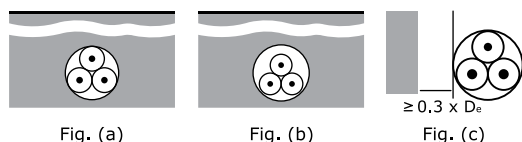

Laying Conditions: Ambient air temperature of 40 °C, Ambient ground temperature of 30 °C, Soil thermal resistivity of 1.5 K·m/W, Depth of laying of 0.8 m. and cable screens are bonded at both ends. In case of different laying conditions, appropriate correction (derating) factors from *Annex E* have to be applied to cater for the actual installation conditions.

Single-Core Cables, with Aluminum Conductors, XLPE Insulated, Wire Armoured and PVC Sheathed

APPLICATION

Suitable for installations indoors: mostly in power supply stations and outdoors: in cable ducts, underground, and on cable trays for industries, switch-boards and power stations. Due to the good laying and mechanical characteristics, this cable is suitable when mechanical protection is required or in applications where mechanical damages are expected to occur.

APPLICABLE STANDARDS

alfanar medium voltage cables are designed and tested to meet or exceed the requirements of IEC 60502-2 standard and/or BS 6622 standard with rated voltage 3.8 / 6.6 (7.2) kV. However, **alfanar** can also supply a range of alternative designs to meet customer-specified requirements.

CABLE CONSTRUCTION

Conductor

Stranded circular compacted aluminum conductor (Class 2).

Conductor Screen

Extruded layer of a cross-linkable semi-conducting compound as a stress control layer.

Insulation

Extruded layer of cross-linked polyethylene (XLPE).

Insulation Screen

Extruded layer of a cross-linkable semi-conducting compound firmly bonded to the insulation.

Metallic Screen

Flat plain copper tape helically applied over the insulation screen with suitable overlap.

Bedding

Extruded layer of Polyvinyl chloride (PVC).

Armouring

Single layer of round non-magnetic (aluminum) wires.

Outer Jacket

Extruded layer of Polyvinyl chloride (PVC).

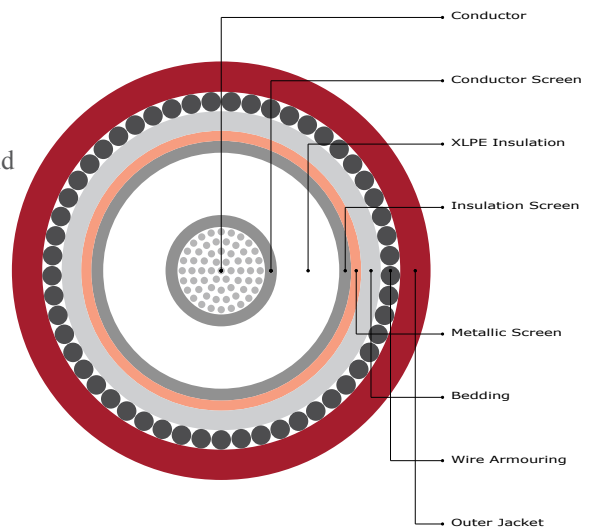

Note: The conductor screen, XLPE insulation and the insulation screen are extruded simultaneously in one process using triple extrusion method (Continuous Vulcanization Line). Triple extrusion method not only assures clean interfaces between the insulation and stress control layers, but also assures a construction free of Partial Discharge with high operational reliability.

TECHNICAL DATA

Rated voltage $U_0 / U (U_m)$	3.6 / 6 (7.2)	kV
Impulse test voltage (peak value)	60	kV
Power frequency test voltage for 5 minutes	12.5	kV
Max. conductor operating temperature at Normal conditions	90	°C
Max. conductor operating temperature at Emergency conditions	130	°C
Max. conductor operating temperature at Short circuit conditions	250	°C
Min. bending radius during installation in terms of cable outer diameter	15 \emptyset	

The above data is approximate and subject to manufacturing tolerance.

We reserve the right to change the above figures as a result of product development and/or changes in standard.

Constructional Data

Conductor		Insulation			Screen	Armour	Packing			Cable Code
Nominal area of conductor	Approx. conductor diameter	Thickness of insulation layers			Approx. metallic screen tape thickness	Wire diameter	Approx. overall diameter	Approx. overall weight	Standard cutting length $\pm 5\%$	
		C.S	XLPE	I.S						
mm ²	mm	mm	mm	mm	mm	mm	mm	kg / km	m	
25	5.85	0.3	2.5	0.3	0.076	1.60	22.7	645	1000	A316XF1BBAMRDXXI0MR
35	6.90	0.3	2.5	0.3	0.076	1.60	23.7	708	1000	A317XF1BBAMRDXXI0MR
50	8.10	0.3	2.5	0.3	0.076	1.60	25.1	802	1000	A318XF1BBAMRDXXI0MR
70	9.70	0.3	2.5	0.3	0.076	1.60	26.7	920	1000	A319XF1BBAMRDXXI0MR
95	11.30	0.3	2.5	0.3	0.076	1.60	28.5	1065	1000	A345XF1BBAMRDXXI0MR
120	12.60	0.3	2.5	0.3	0.076	1.60	29.8	1185	1000	A346XF1BBAMRDXXI0MR
150	14.10	0.3	2.5	0.3	0.076	1.60	31.5	1332	1000	A347XF1BBAMRDXXI0MR
185	15.80	0.3	2.5	0.3	0.076	2.00	34.2	1602	1000	A348XF1BBAMRDXXI0MR
240	18.10	0.3	2.6	0.3	0.076	2.00	36.7	1865	1000	A349XF1BBAMRDXXI0MR
300	20.50	0.3	2.8	0.3	0.076	2.00	39.7	2179	1000	A350XF1BBAMRDXXI0MR
400	23.10	0.3	3.0	0.3	0.076	2.00	42.9	2583	1000	A351XF1BBAMRDXXI0MR
500	26.50	0.3	3.2	0.3	0.076	2.50	48.3	3295	1000	A352XF1BBAMRDXXI0MR
630	30.05	0.3	3.2	0.3	0.076	2.50	52.3	3899	1000	A353XF1BBAMRDXXI0MR
800	34.00	0.3	3.2	0.3	0.076	2.50	56.6	4672	500	A354XF1BBAMRDXXI0MF
1000	40.00	0.3	3.2	0.3	0.076	2.50	64.6	5753	500	A755XF1BBAMRDXXI0MF

Electrical Data

Nominal area of conductor	Electrical Characteristics					Continuous Current Ratings						
	Max. Conductor Resistance		Reactance (60 Hz)	Impedance (90 °C, 60 Hz)	Capacitance	Buried direct in the ground		In single-way ducts		In air		
	DC at 20 °C	AC at 90 °C				Trefoil	Flat spaced	Trefoil	Flat touched	Trefoil	Flat touched	Flat spaced
	mm ²	Ω / km	Ω / km	Ω / km	Ω / km	$\mu\text{F} / \text{km}$	A	A	A	A	A	A
25	1.2000	1.5386	0.172	1.548	0.255	98	103	90	91	112	114	133
35	0.8680	1.1130	0.164	1.125	0.283	117	122	108	108	135	139	161
50	0.6410	0.8220	0.152	0.836	0.317	138	143	128	127	163	166	193
70	0.4430	0.5683	0.145	0.586	0.362	168	175	156	156	203	207	241
95	0.3200	0.4108	0.138	0.433	0.407	201	208	187	185	246	252	292
120	0.2530	0.3251	0.134	0.351	0.444	227	235	212	210	284	290	335
150	0.2060	0.2650	0.129	0.295	0.486	254	261	237	235	323	329	380
185	0.1640	0.2115	0.124	0.245	0.533	287	294	269	265	371	378	435
240	0.1250	0.1619	0.120	0.202	0.577	331	337	311	305	439	445	510
300	0.1000	0.1303	0.117	0.175	0.600	374	376	350	342	505	511	582
400	0.0778	0.1026	0.114	0.153	0.625	424	422	399	387	586	590	668
500	0.0605	0.0813	0.111	0.137	0.664	481	472	454	436	682	683	768
630	0.0469	0.0650	0.108	0.126	0.742	540	513	508	479	785	775	858
800	0.0367	0.0533	0.105	0.118	0.831	597	549	560	517	891	867	944
1000	0.0291	0.0387	0.101	0.109	0.992	694	593	635	569	1078	1022	1063

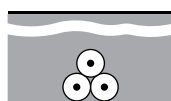

Fig. (a)

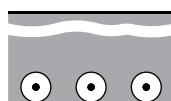

Fig. (b)

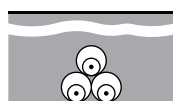

Fig. (c)

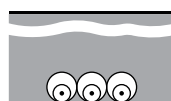

Fig. (d)

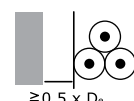

Fig. (e)

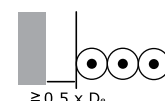

Fig. (f)

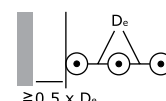

Fig. (g)

Laying Conditions: Ambient air temperature of 40 °C, Ambient ground temperature of 30 °C, Soil thermal resistivity of 1.5 K·m/W, Depth of laying of 0.8 m, and cable screens are bonded at both ends. In case of different laying conditions, appropriate correction (derating) factors from *Annex E* have to be applied to cater for the actual installation conditions.

Three-Core Cables, with Aluminum Conductors, XLPE Insulated, Wire Armoured and PVC Sheathed

APPLICATION

Suitable for installations indoors: mostly in power supply stations and outdoors: in cable ducts, underground, and on cable trays for industries, switch-boards and power stations. Due to the good laying and mechanical characteristics, this cable is suitable when mechanical protection is required or in applications where mechanical damages are expected to occur.

APPLICABLE STANDARDS

alfanar medium voltage cables are designed and tested to meet or exceed the requirements of IEC 60502-2 standard and/or BS 6622 standard with rated voltage 3.8 / 6.6 (7.2) kV. However, **alfanar** can also supply a range of alternative designs to meet customer-specified requirements.

CABLE CONSTRUCTION

Conductor

Stranded circular compacted aluminum conductor (Class 2).

Conductor Screen

Extruded layer of a cross-linkable semi-conducting compound as a stress control layer.

Insulation

Extruded layer of cross-linked polyethylene (XLPE).

Insulation Screen

Extruded layer of a cross-linkable semi-conducting compound firmly bonded to the insulation.

Metallic Screen

Flat plain copper tape helically applied over the insulation screen with suitable overlap.

Filler

Non-hygroscopic polypropylene filler suitable for the cable's operating temperature.

Bedding

Extruded layer of Polyvinyl chloride (PVC).

Armouring

Double layer of galvanized steel tapes.

Outer Jacket

Extruded layer of Polyvinyl chloride (PVC).

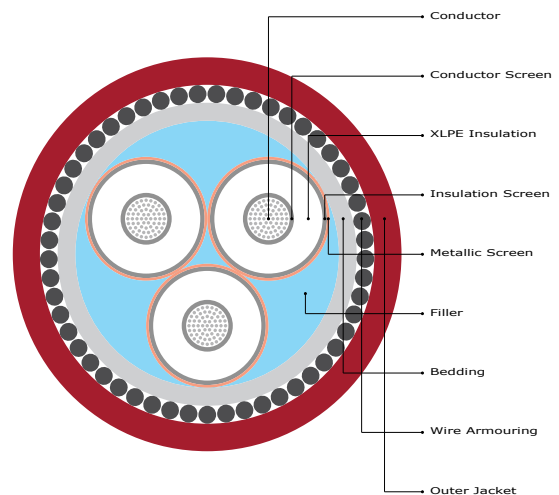

Note: The conductor screen, XLPE insulation and the insulation screen are extruded simultaneously in one process using triple extrusion method (Continuous Vulcanization Line). Triple extrusion method not only assures clean interfaces between the insulation and stress control layers, but also assures a construction free of Partial Discharge with high operational reliability.

TECHNICAL DATA

Rated voltage $U_0 / U (U_m)$	3.6 / 6 (7.2)	kV
Impulse test voltage (peak value)	60	kV
Power frequency test voltage for 5 minutes	12.5	kV
Max. conductor operating temperature at Normal conditions	90	°C
Max. conductor operating temperature at Emergency conditions	130	°C
Max. conductor operating temperature at Short circuit conditions	250	°C
Min. bending radius during installation in terms of cable outer diameter	12 \emptyset	

Constructional Data

Conductor		Insulation			Screen	Armour	Packing			Cable Code
Nominal area of conductor	Approx. conductor diameter	Thickness of insulation layers			Approx. metallic screen tape thickness	Wire diameter	Approx. overall diameter	Approx. overall weight	Standard cutting length $\pm 5\%$	
		C.S.	XLPE	I.S.						
mm ²	mm	Min.	Nom.	Min.	mm	mm	mm	kg / km	m	
25	5.85	0.3	2.5	0.3	0.076	2.00	40.0	2617	1000	A316XF3BBWMDXXI0MR
35	6.90	0.3	2.5	0.3	0.076	2.50	43.6	3310	1000	A317XF3BBWMDXXI0MR
50	8.10	0.3	2.5	0.3	0.076	2.50	46.4	3683	1000	A318XF3BBWMDXXI0MR
70	9.70	0.3	2.5	0.3	0.076	2.50	50.2	4225	1000	A319XF3BBWMDXXI0MR
95	11.30	0.3	2.5	0.3	0.076	2.50	53.9	4796	500	A345XF3BBWMDXXI0MF
120	12.60	0.3	2.5	0.3	0.076	2.50	57.3	5361	500	A346XF3BBWMDXXI0MF
150	14.10	0.3	2.5	0.3	0.076	2.50	60.9	5968	500	A347XF3BBWMDXXI0MF
185	15.80	0.3	2.5	0.3	0.076	2.50	64.8	6676	500	A348XF3BBWMDXXI0MF
240	18.10	0.3	2.6	0.3	0.076	2.50	70.8	7856	500	A349XF3BBWMDXXI0MF
300	20.50	0.3	2.8	0.3	0.076	3.15	79.3	10188	500	A350XF3BBWMDXXI0MF
400	23.10	0.3	3.0	0.3	0.076	3.15	86.8	11954	500	A351XF3BBWMDXXI0MF

Electrical Data

Nominal area of conductor	Electrical Characteristics					Continuous Current Ratings		
	Max. Conductor Resistance		Reactance (60 Hz)	Impedance (90 °C, 60 Hz)	Capacitance	Buried direct in the ground	In a buried duct	In air
	DC at 20 °C	AC at 90 °C				Fig. (a)	Fig. (b)	Fig. (c)
mm ²	Ω / km	Ω / km	Ω / km	Ω / km	$\mu\text{F} / \text{km}$	A	A	A
25	1.2000	1.5387	0.141	1.545	0.255	95	81	103
35	0.8680	1.1131	0.133	1.121	0.283	113	97	124
50	0.6410	0.8221	0.124	0.831	0.317	133	114	147
70	0.4430	0.5685	0.118	0.581	0.362	162	140	183
95	0.3200	0.4110	0.113	0.426	0.407	192	168	221
120	0.2530	0.3254	0.110	0.343	0.444	218	191	253
150	0.2060	0.2654	0.107	0.286	0.486	244	215	287
185	0.1640	0.2120	0.103	0.236	0.533	275	244	328
240	0.1250	0.1626	0.100	0.191	0.577	318	284	385
300	0.1000	0.1312	0.099	0.164	0.600	357	321	439
400	0.0778	0.1037	0.097	0.142	0.625	406	368	508

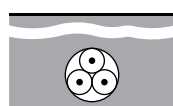

Fig. (a)

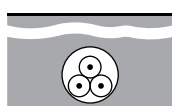

Fig. (b)



Fig. (c)

Laying Conditions: Ambient air temperature of 40 °C, Ambient ground temperature of 30 °C, Soil thermal resistivity of 1.5 K·m/W, Depth of laying of 0.8 m. and cable screens are bonded at both ends. In case of different laying conditions, appropriate correction (derating) factors from *Annex E* have to be applied to cater for the actual installation conditions.

Single-Core Cables, with Copper Conductors, XLPE Insulated and PVC Sheathed

APPLICATION

Suitable for installations indoors: mostly in power supply stations and outdoors: in cable ducts, underground, and on cable trays for industries, switch-boards and power stations.

APPLICABLE STANDARDS

alfanar medium voltage cables are designed and tested to meet or exceed the requirements of IEC 60502-2 standard. However, **alfanar** can also supply a range of alternative designs to meet customer-specified requirements.

CABLE CONSTRUCTION

Conductor

Plain annealed stranded circular compacted copper conductor (Class 2).

Conductor Screen

Extruded layer of a cross-linkable semi-conducting compound as a stress control layer.

Insulation

Extruded layer of cross-linked polyethylene (XLPE).

Insulation Screen

Extruded layer of a cross-linkable semi-conducting compound firmly bonded to the insulation.

Metallic Screen

Flat plain copper tape helically applied over the insulation screen with suitable overlap.

Outer Jacket

Extruded layer of Polyvinyl chloride (PVC).

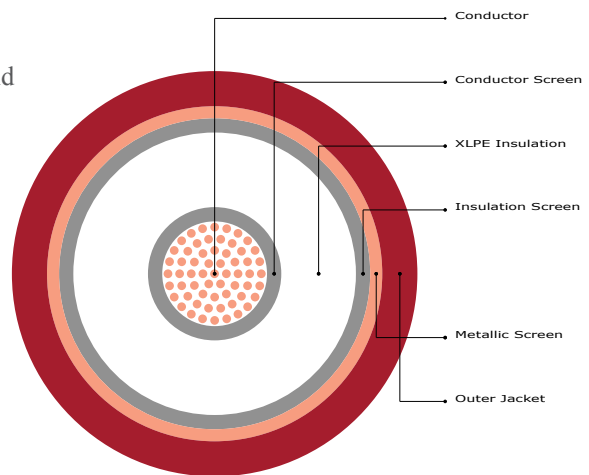

Note: The conductor screen, XLPE insulation and the insulation screen are extruded simultaneously in one process using triple extrusion method (Continuous Vulcanization Line). Triple extrusion method not only assures clean interfaces between the insulation and stress control layers, but also assures a construction free of Partial Discharge with high operational reliability.

TECHNICAL DATA

Rated voltage $U_0 / U (U_m)$	6 / 10 (12)	kV
Impulse test voltage (peak value)	75	kV
Power frequency test voltage for 5 minutes	21	kV
Max. conductor operating temperature at Normal conditions	90	°C
Max. conductor operating temperature at Emergency conditions	130	°C
Max. conductor operating temperature at Short circuit conditions	250	°C
Min. bending radius during installation in terms of cable outer diameter	20 Ø	

The above data is approximate and subject to manufacturing tolerance.

We reserve the right to change the above figures as a result of product development and/or changes in standard.

Constructional Data

Conductor		Insulation			Screen	Armour	Packing			Cable Code
Nominal area of conductor	Approx. conductor diameter	Thickness of insulation layers			Approx. metallic screen tape thickness	N / A	Approx. overall diameter	Approx. overall weight	Standard cutting length $\pm 5\%$	
		C.S	XLPE	I.S						
mm ²	mm	Min.	Nom.	Min.	mm	mm	mm	kg / km	m	
25	5.85	0.3	3.4	0.3	0.076	-	18.2	530	1000	C316XH1BB0MRDXXI0MR
35	6.90	0.3	3.4	0.3	0.076	-	19.2	639	1000	C317XH1BB0MRDXXI0MR
50	8.10	0.3	3.4	0.3	0.076	-	20.4	782	1000	C318XH1BB0MRDXXI0MR
70	9.70	0.3	3.4	0.3	0.076	-	22.2	1012	1000	C319XH1BB0MRDXXI0MR
95	11.30	0.3	3.4	0.3	0.076	-	23.8	1276	1000	C345XH1BB0MRDXXI0MR
120	12.60	0.3	3.4	0.3	0.076	-	25.3	1547	1000	C346XH1BB0MRDXXI0MR
150	14.10	0.3	3.4	0.3	0.076	-	26.8	1810	1000	C347XH1BB0MRDXXI0MR
185	15.80	0.3	3.4	0.3	0.076	-	28.7	2214	1000	C348XH1BB0MRDXXI0MR
240	18.10	0.3	3.4	0.3	0.076	-	31.2	2789	1000	C349XH1BB0MRDXXI0MR
300	20.50	0.3	3.4	0.3	0.076	-	33.6	3397	1000	C350XH1BB0MRDXXI0MR
400	23.10	0.3	3.4	0.3	0.076	-	36.6	4260	1000	C351XH1BB0MRDXXI0MR
500	26.50	0.3	3.4	0.3	0.076	-	40.0	5393	500	C352XH1BB0MRDXXI0MF
630	30.05	0.3	3.4	0.3	0.076	-	44.0	6716	500	C353XH1BB0MRDXXI0MF
800	34.00	0.3	3.4	0.3	0.076	-	48.3	8546	500	C354XH1BB0MRDXXI0MF
1000	40.00	0.3	3.4	0.3	0.076	-	55.9	10748	500	C755XH1BB0MRDXXI0MF

Electrical Data

Nominal area of conductor	Electrical Characteristics					Continuous Current Ratings						
	Max. Conductor Resistance		Reactance (60 Hz)	Impedance (90 °C, 60 Hz)	Capacitance	Buried direct in the ground		In single-way ducts		In air		
	DC at 20 °C	AC at 90 °C				Trefoil	Flat spaced	Trefoil	Flat touched	Trefoil	Flat touched	Flat spaced
	mm ²	Ω / km	Ω / km	Ω / km	Ω / km	$\mu\text{F} / \text{km}$	A	A	A	A	A	A
25	1.2000	1.5386	0.172	1.548	0.255	98	103	90	91	112	114	133
35	0.8680	1.1130	0.164	1.125	0.283	117	122	108	108	135	139	161
50	0.6410	0.8220	0.152	0.836	0.317	138	143	128	127	163	166	193
70	0.4430	0.5683	0.145	0.586	0.362	168	175	156	156	203	207	241
95	0.3200	0.4108	0.138	0.433	0.407	201	208	187	185	246	252	292
120	0.2530	0.3251	0.134	0.351	0.444	227	235	212	210	284	290	335
150	0.2060	0.2650	0.129	0.295	0.486	254	261	237	235	323	329	380
185	0.1640	0.2115	0.124	0.245	0.533	287	294	269	265	371	378	435
240	0.1250	0.1619	0.120	0.202	0.577	331	337	311	305	439	445	510
300	0.1000	0.1303	0.117	0.175	0.600	374	376	350	342	505	511	582
400	0.0778	0.1026	0.114	0.153	0.625	424	422	399	387	586	590	668
500	0.0605	0.0813	0.111	0.137	0.664	481	472	454	436	682	683	768
630	0.0469	0.0650	0.108	0.126	0.742	540	513	508	479	785	775	858
800	0.0367	0.0533	0.105	0.118	0.831	597	549	560	517	891	867	944
1000	0.0291	0.0387	0.101	0.109	0.992	694	593	635	569	1078	1022	1063

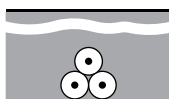

Fig. (a)

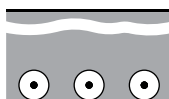

Fig. (b)

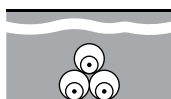

Fig. (c)

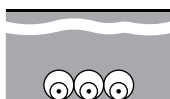

Fig. (d)



Fig. (e)



Fig. (f)

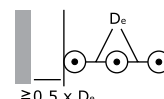

Fig. (g)

Laying Conditions: Ambient air temperature of 40 °C, Ambient ground temperature of 30 °C, Soil thermal resistivity of 1.5 K·m/W, Depth of laying of 0.8 m, and cable screens are bonded at both ends. In case of different laying conditions, appropriate correction (derating) factors from *Annex E* have to be applied to cater for the actual installation conditions.

Three-Core Cables, with Copper Conductors, XLPE Insulated and PVC Sheathed

APPLICATION

Suitable for installations indoors: mostly in power supply stations and outdoors: in cable ducts, underground, and on cable trays for industries, switch-boards and power stations.

APPLICABLE STANDARDS

alfanar medium voltage cables are designed and tested to meet or exceed the requirements of IEC 60502-2 standard. However, **alfanar** can also supply a range of alternative designs to meet customer-specified requirements.

CABLE CONSTRUCTION

Conductor

Plain annealed stranded circular compacted copper conductor (Class 2).

Conductor Screen

Extruded layer of a cross-linkable semi-conducting compound as a stress control layer.

Insulation

Extruded layer of cross-linked polyethylene (XLPE).

Insulation Screen

Extruded layer of a cross-linkable semi-conducting compound firmly bonded to the insulation.

Metallic Screen

Flat plain copper tape helically applied over the insulation screen with suitable overlap.

Filler

Non-hygroscopic polypropylene filler suitable for the cable's operating temperature.

Outer Jacket

Extruded layer of Polyvinyl chloride (PVC).

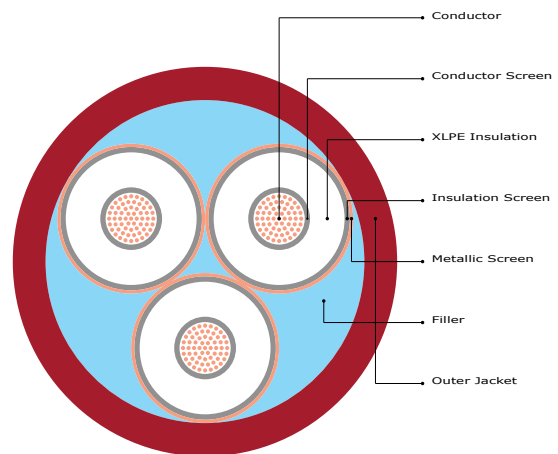

Note: The conductor screen, XLPE insulation and the insulation screen are extruded simultaneously in one process using triple extrusion method (Continuous Vulcanization Line). Triple extrusion method not only assures clean interfaces between the insulation and stress control layers, but also assures a construction free of Partial Discharge with high operational reliability.

TECHNICAL DATA

Rated voltage $U_0 / U (U_m)$	6 / 10 (12)	kV
Impulse test voltage (peak value)	75	kV
Power frequency test voltage for 5 minutes	21	kV
Max. conductor operating temperature at Normal conditions	90	°C
Max. conductor operating temperature at Emergency conditions	130	°C
Max. conductor operating temperature at Short circuit conditions	250	°C
Min. bending radius during installation in terms of cable outer diameter	15 Ø	

The above data is approximate and subject to manufacturing tolerance.

We reserve the right to change the above figures as a result of product development and/or changes in standard.

Constructional Data

Conductor		Insulation			Screen	Armour	Packing			Cable Code
Nominal area of conductor	Approx. conductor diameter	Thickness of insulation layers			Approx. metallic screen tape thickness	N/A	Approx. overall diameter	Approx. overall weight	Standard cutting length $\pm 5\%$	
		C.S	XLPE	I.S						
mm ²	mm	Min.	Nom.	Min.	mm	mm	mm	kg / km	m	
25	5.85	0.3	3.4	0.3	0.076	-	37.3	1724	1000	C316XH3BB0MRDXXI0MR
35	6.90	0.3	3.4	0.3	0.076	-	39.7	2092	1000	C317XH3BB0MRDXXI0MR
50	8.10	0.3	3.4	0.3	0.076	-	42.5	2566	1000	C318XH3BB0MRDXXI0MR
70	9.70	0.3	3.4	0.3	0.076	-	46.1	3285	1000	C319XH3BB0MRDXXI0MR
95	11.30	0.3	3.4	0.3	0.076	-	49.8	4141	1000	C345XH3BB0MRDXXI0MR
120	12.60	0.3	3.4	0.3	0.076	-	52.8	4982	500	C346XH3BB0MRDXXI0MF
150	14.10	0.3	3.4	0.3	0.076	-	56.2	5843	500	C347XH3BB0MRDXXI0MF
185	15.80	0.3	3.4	0.3	0.076	-	60.1	7097	500	C348XH3BB0MRDXXI0MF
240	18.10	0.3	3.4	0.3	0.076	-	65.5	8924	500	C349XH3BB0MRDXXI0MF
300	20.50	0.3	3.4	0.3	0.076	-	71.0	10904	400	C350XH3BB0MRDXXI0MU
400	23.10	0.3	3.4	0.3	0.076	-	77.1	13583	400	C351XH3BB0MRDXXI0MU

Electrical Data

Nominal area of conductor	Electrical Characteristics					Continuous Current Ratings		
	Max. Conductor Resistance		Reactance (60 Hz)	Impedance (90 °C, 60 Hz)	Capacitance	Buried direct in the ground	In a buried duct	In air
	DC at 20 °C	AC at 90 °C				Fig. (a)	Fig. (b)	Fig. (c)
mm ²	Ω / km	Ω / km	Ω / km	Ω / km	$\mu\text{F} / \text{km}$	A	A	A
25	0.7270	0.9272	0.150	0.939	0.202	128	106	141
35	0.5240	0.6685	0.143	0.684	0.224	152	127	171
50	0.3870	0.4939	0.133	0.511	0.249	179	151	204
70	0.2680	0.3425	0.126	0.365	0.282	218	185	254
95	0.1930	0.2472	0.120	0.275	0.316	260	222	309
120	0.1530	0.1966	0.116	0.228	0.343	294	253	355
150	0.1240	0.1601	0.113	0.196	0.374	329	284	403
185	0.0991	0.1289	0.109	0.169	0.409	371	322	462
240	0.0754	0.0997	0.105	0.145	0.456	426	374	542
300	0.0601	0.0812	0.102	0.130	0.505	478	422	619
400	0.0470	0.0659	0.099	0.119	0.559	536	477	708

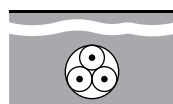

Fig. (a)

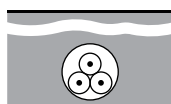

Fig. (b)



Fig. (c)

Laying Conditions: Ambient air temperature of 40 °C, Ambient ground temperature of 30 °C, Soil thermal resistivity of 1.5 K·m/W, Depth of laying of 0.8 m, and cable screens are bonded at both ends. In case of different laying conditions, appropriate correction (derating) factors from *Annex E* have to be applied to cater for the actual installation conditions.

Single-Core Cables, with Copper Conductors, XLPE Insulated, Tape Armoured and PVC Sheathed

APPLICATION

Suitable for installations indoors: mostly in power supply stations and outdoors: in cable ducts, underground, and on cable trays for industries, switch-boards and power stations. Due to the good laying and mechanical characteristics, this cable is suitable when mechanical protection is required or in applications where mechanical damages are expected to occur.

APPLICABLE STANDARDS

alfanar medium voltage cables are designed and tested to meet or exceed the requirements of IEC 60502-2 standard. However, **alfanar** can also supply a range of alternative designs to meet customer-specified requirements.

CABLE CONSTRUCTION

Conductor

Plain annealed stranded circular compacted copper conductor (Class 2).

Conductor Screen

Extruded layer of a cross-linkable semi-conducting compound as a stress control layer.

Insulation

Extruded layer of cross-linked polyethylene (XLPE).

Insulation Screen

Extruded layer of a cross-linkable semi-conducting compound firmly bonded to the insulation.

Metallic Screen

Flat plain copper tape helically applied over the insulation screen with suitable overlap.

Bedding

Extruded layer of Polyvinyl chloride (PVC).

Armouring

Double layer of non-magnetic (aluminum) tapes.

Outer Jacket

Extruded layer of Polyvinyl chloride (PVC).

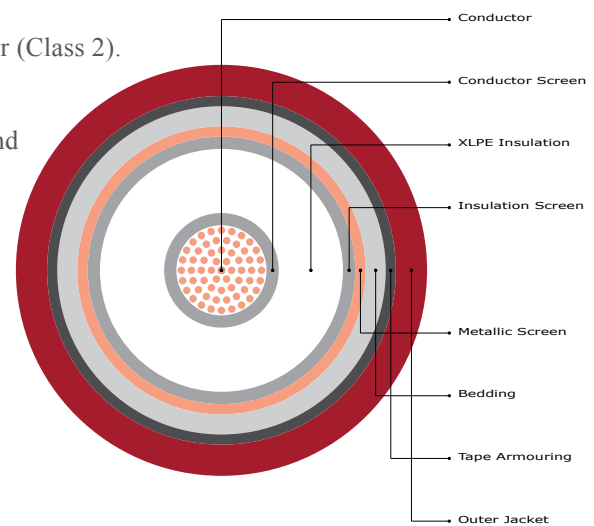

Note: The conductor screen, XLPE insulation and the insulation screen are extruded simultaneously in one process using triple extrusion method (Continuous Vulcanization Line). Triple extrusion method not only assures clean interfaces between the insulation and stress control layers, but also assures a construction free of Partial Discharge with high operational reliability.

TECHNICAL DATA

Rated voltage $U_0 / U (U_m)$	6 / 10 (12)	kV
Impulse test voltage (peak value)	75	kV
Power frequency test voltage for 5 minutes	21	kV
Max. conductor operating temperature at Normal conditions	90	°C
Max. conductor operating temperature at Emergency conditions	130	°C
Max. conductor operating temperature at Short circuit conditions	250	°C
Min. bending radius during installation in terms of cable outer diameter	15 Ø	

The above data is approximate and subject to manufacturing tolerance.

We reserve the right to change the above figures as a result of product development and/or changes in standard.

Constructional Data

Conductor		Insulation			Screen	Armour	Packing			Cable Code
Nominal area of conductor	Approx. conductor diameter	Thickness of insulation layers			Approx. metallic screen tape thickness	Tape thickness	Approx. overall diameter	Approx. overall weight	Standard cutting length $\pm 5\%$	
		C.S	XLPE	I.S						
mm ²	mm	Min.	Nom.	Min.	mm	mm	mm	kg / km	m	
25	5.85	0.3	3.4	0.3	0.076	0.50	22.8	778	1000	C316XH1BBBMRDXXI0MR
35	6.90	0.3	3.4	0.3	0.076	0.50	23.8	900	1000	C317XH1BBBMRDXXI0MR
50	8.10	0.3	3.4	0.3	0.076	0.50	25.2	1068	1000	C318XH1BBBMRDXXI0MR
70	9.70	0.3	3.4	0.3	0.076	0.50	26.8	1310	1000	C319XH1BBBMRDXXI0MR
95	11.30	0.3	3.4	0.3	0.076	0.50	28.6	1606	1000	C345XH1BBBMRDXXI0MR
120	12.60	0.3	3.4	0.3	0.076	0.50	29.9	1881	1000	C346XH1BBBMRDXXI0MR
150	14.10	0.3	3.4	0.3	0.076	0.50	31.6	2178	1000	C347XH1BBBMRDXXI0MR
185	15.80	0.3	3.4	0.3	0.076	0.50	33.5	2606	1000	C348XH1BBBMRDXXI0MR
240	18.10	0.3	3.4	0.3	0.076	0.50	35.8	3195	1000	C349XH1BBBMRDXXI0MR
300	20.50	0.3	3.4	0.3	0.076	0.50	38.4	3851	1000	C350XH1BBBMRDXXI0MR
400	23.10	0.3	3.4	0.3	0.076	0.50	41.4	4752	1000	C351XH1BBBMRDXXI0MR
500	26.50	0.3	3.4	0.3	0.076	0.50	45.0	5950	500	C352XH1BBBMRDXXI0MF
630	30.05	0.3	3.4	0.3	0.076	0.50	49.0	7325	500	C353XH1BBBMRDXXI0MF
800	34.00	0.3	3.4	0.3	0.076	0.50	53.3	9212	500	C354XH1BBBMRDXXI0MF
1000	40.00	0.3	3.4	0.3	0.076	0.50	61.3	11574	500	C755XH1BBBMRDXXI0MF

Electrical Data

Nominal area of conductor	Electrical Characteristics					Continuous Current Ratings						
	Max. Conductor Resistance		Reactance (60 Hz)	Impedance (90 °C, 60 Hz)	Capacitance	Buried direct in the ground		In single-way ducts		In air		
	DC at 20 °C	AC at 90 °C				Trefoil	Flat spaced	Trefoil	Flat touched	Trefoil	Flat touched	Flat spaced
	mm ²	Ω / km	Ω / km	Ω / km	Ω / km	μF / km	A	A	A	A	A	A
25	0.7270	0.9272	0.179	0.944	0.202	127	132	116	116	144	147	171
35	0.5240	0.6684	0.170	0.690	0.224	151	157	139	139	175	178	207
50	0.3870	0.4938	0.159	0.519	0.249	178	184	164	163	209	214	248
70	0.2680	0.3423	0.150	0.374	0.282	217	224	200	199	261	266	308
95	0.1930	0.2469	0.143	0.285	0.316	258	265	239	237	317	323	373
120	0.1530	0.1962	0.138	0.240	0.343	291	298	271	267	364	370	426
150	0.1240	0.1595	0.134	0.208	0.374	326	331	303	298	414	420	482
185	0.0991	0.1282	0.129	0.182	0.409	366	369	341	334	474	480	548
240	0.0754	0.0987	0.124	0.158	0.456	421	419	393	381	558	562	639
300	0.0601	0.0800	0.119	0.144	0.505	473	464	441	425	639	640	723
400	0.0470	0.0643	0.116	0.132	0.559	530	513	496	473	733	730	817
500	0.0366	0.0523	0.112	0.123	0.629	592	564	556	524	841	830	924
630	0.0283	0.0431	0.109	0.117	0.702	652	597	610	562	949	921	1006
800	0.0221	0.0366	0.106	0.112	0.786	705	622	657	591	1054	1005	1080
1000	0.0176	0.0247	0.102	0.105	0.938	831	662	743	643	1296	1188	1201

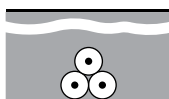

Fig. (a)

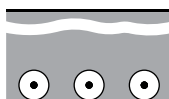

Fig. (b)

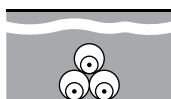

Fig. (c)

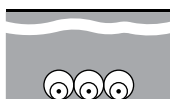

Fig. (d)



Fig. (e)

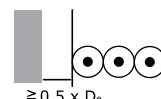

Fig. (f)

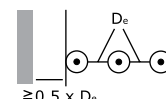

Fig. (g)

Laying Conditions: Ambient air temperature of 40 °C, Ambient ground temperature of 30 °C, Soil thermal resistivity of 1.5 K·m/W, Depth of laying of 0.8 m, and cable screens are bonded at both ends. In case of different laying conditions, appropriate correction (derating) factors from *Annex E* have to be applied to cater for the actual installation conditions.

Three-Core Cables, with Copper Conductors, XLPE Insulated, Tape Armoured and PVC Sheathed

APPLICATION

uitable for installations indoors: mostly in power supply stations and outdoors: in cable ducts, underground, and on cable trays for industries, switch-boards and power stations. Due to the good laying and mechanical characteristics, this cable is suitable when mechanical protection is required or in applications where mechanical damages are expected to occur.

APPLICABLE STANDARDS

alfanar medium voltage cables are designed and tested to meet or exceed the requirements of IEC 60502-2 standard. However, **alfanar** can also supply a range of alternative designs to meet customer-specified requirements.

CABLE CONSTRUCTION

Conductor

Plain annealed stranded circular compacted copper conductor (Class 2).

Conductor Screen

Extruded layer of a cross-linkable semi-conducting compound as a stress control layer.

Insulation

Extruded layer of cross-linked polyethylene (XLPE).

Insulation Screen

Extruded layer of a cross-linkable semi-conducting compound firmly bonded to the insulation.

Metallic Screen

Flat plain copper tape helically applied over the insulation screen with suitable overlap.

Filler

Non-hygroscopic polypropylene filler suitable for the cable's operating temperature.

Bedding

Extruded layer of Polyvinyl chloride (PVC).

Armouring

Double layer of galvanized steel tapes.

Outer Jacket

Extruded layer of Polyvinyl chloride (PVC).

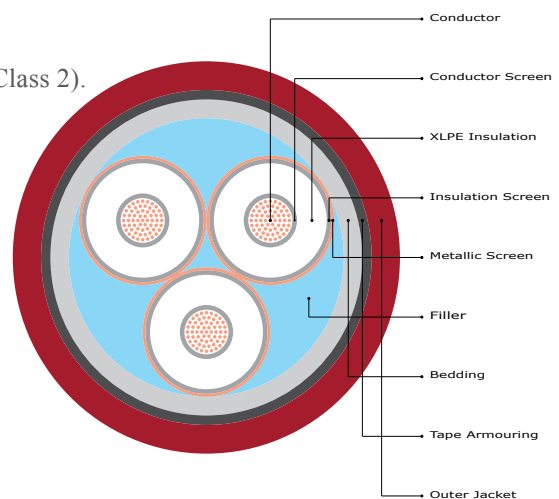

Note: The conductor screen, XLPE insulation and the insulation screen are extruded simultaneously in one process using triple extrusion method (Continuous Vulcanization Line). Triple extrusion method not only assures clean interfaces between the insulation and stress control layers, but also assures a construction free of Partial Discharge with high operational reliability.

TECHNICAL DATA

Rated voltage U_0 / U (Um)	6 / 10 (12)	kV
Impulse test voltage (peak value)	75	kV
Power frequency test voltage for 5 minutes	21	kV
Max. conductor operating temperature at Normal conditions	90	°C
Max. conductor operating temperature at Emergency conditions	130	°C
Max. conductor operating temperature at Short circuit conditions	250	°C
Min. bending radius during installation in terms of cable outer diameter	12 \emptyset	

Constructional Data

Conductor		Insulation			Screen	Armour	Packing			Cable Code
Nominal area of conductor	Approx. conductor diameter	Thickness of insulation layers			Approx. metallic screen tape thickness	Tape thickness	Approx. overall diameter	Approx. overall weight	Standard cutting length $\pm 5\%$	
		C.S.	XLPE	I.S.						
mm ²	mm	Min.	Nom.	Min.	mm	mm	mm	kg / km	m	
25	5.85	0.3	3.4	0.3	0.076	0.50	42.3	2638	1000	C316XH3BBGMRDXXI0MR
35	6.90	0.3	3.4	0.3	0.076	0.50	44.5	3040	1000	C317XH3BBGMRDXXI0MR
50	8.10	0.3	3.4	0.3	0.076	0.50	47.7	3626	1000	C318XH3BBGMRDXXI0MR
70	9.70	0.3	3.4	0.3	0.076	0.50	51.5	4458	1000	C319XH3BBGMRDXXI0MR
95	11.30	0.3	3.4	0.3	0.076	0.50	55.2	5404	500	C345XH3BBGMRDXXI0MF
120	12.60	0.3	3.4	0.3	0.076	0.50	58.4	6348	500	C346XH3BBGMRDXXI0MF
150	14.10	0.3	3.4	0.3	0.076	0.50	61.8	7293	500	C347XH3BBGMRDXXI0MF
185	15.80	0.3	3.4	0.3	0.076	0.50	65.9	8679	500	C348XH3BBGMRDXXI0MF
240	18.10	0.3	3.4	0.3	0.076	0.50	71.5	10679	400	C349XH3BBGMRDXXI0MU
300	20.50	0.3	3.4	0.3	0.076	0.50	77.2	12840	400	C350XH3BBGMRDXXI0MU
400	23.10	0.3	3.4	0.3	0.076	0.80	84.7	16503	400	C351XH3BBGMRDXXI0MU

Electrical Data

Nominal area of conductor	Electrical Characteristics					Continuous Current Ratings		
	Max. Conductor Resistance		Reactance (60 Hz)	Impedance (90 °C, 60 Hz)	Capacitance	Buried direct in the ground	In a buried duct	In air
	DC at 20 °C	AC at 90 °C				Fig. (a)	Fig. (b)	Fig. (c)
mm ²	Ω / km	Ω / km	Ω / km	Ω / km	$\mu\text{F} / \text{km}$	A	A	A
25	0.7270	0.9272	0.150	0.939	0.202	122	104	132
35	0.5240	0.6685	0.143	0.684	0.224	146	125	160
50	0.3870	0.4939	0.133	0.511	0.249	171	147	190
70	0.2680	0.3425	0.126	0.365	0.282	208	180	235
95	0.1930	0.2472	0.120	0.275	0.316	248	216	285
120	0.1530	0.1966	0.116	0.228	0.343	280	245	325
150	0.1240	0.1601	0.113	0.196	0.374	313	276	369
185	0.0991	0.1289	0.109	0.169	0.409	352	312	419
240	0.0754	0.0997	0.105	0.145	0.456	404	360	489
300	0.0601	0.0812	0.102	0.130	0.505	451	405	555
400	0.0470	0.0659	0.099	0.119	0.559	506	458	633

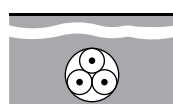

Fig. (a)

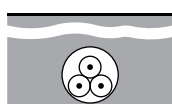

Fig. (b)



Fig. (c)

Laying Conditions: Ambient air temperature of 40 °C, Ambient ground temperature of 30 °C, Soil thermal resistivity of 1.5 K·m/W, Depth of laying of 0.8 m. and cable screens are bonded at both ends. In case of different laying conditions, appropriate correction (derating) factors from *Annex E* have to be applied to cater for the actual installation conditions.

Single-Core Cables, with Copper Conductors, XLPE Insulated, Wire Armoured and PVC Sheathed

APPLICATION

Suitable for installations indoors: mostly in power supply stations and outdoors: in cable ducts, underground, and on cable trays for industries, switch-boards and power stations. Due to the good laying and mechanical characteristics, this cable is suitable when mechanical protection is required or in applications where mechanical damages are expected to occur.

APPLICABLE STANDARDS

alfanar medium voltage cables are designed and tested to meet or exceed the requirements of IEC 60502-2 standard and/or BS 6622 standard with rated voltage 6.35 / 11 (12) kV. However, **alfanar** can also supply a range of alternative designs to meet customer-specified requirements.

CABLE CONSTRUCTION

Conductor

Plain annealed stranded circular compacted copper conductor (Class 2).

Conductor Screen

Extruded layer of a cross-linkable semi-conducting compound as a stress control layer.

Insulation

Extruded layer of cross-linked polyethylene (XLPE).

Insulation Screen

Extruded layer of a cross-linkable semi-conducting compound firmly bonded to the insulation.

Metallic Screen

Flat plain copper tape helically applied over the insulation screen with suitable overlap.

Bedding

Extruded layer of Polyvinyl chloride (PVC).

Armouring

Single layer of round non-magnetic (aluminum) wires.

Outer Jacket

Extruded layer of Polyvinyl chloride (PVC).

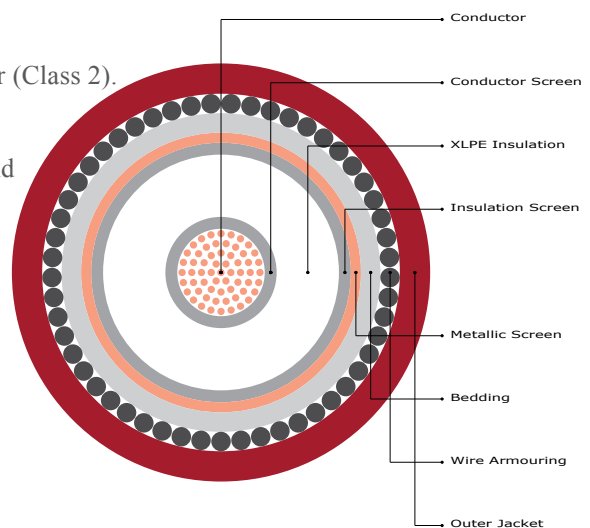

Note: The conductor screen, XLPE insulation and the insulation screen are extruded simultaneously in one process using triple extrusion method (Continuous Vulcanization Line). Triple extrusion method not only assures clean interfaces between the insulation and stress control layers, but also assures a construction free of Partial Discharge with high operational reliability.

TECHNICAL DATA

Rated voltage $U_0 / U (U_m)$	6 / 10 (12)	kV
Impulse test voltage (peak value)	75	kV
Power frequency test voltage for 5 minutes	21	kV
Max. conductor operating temperature at Normal conditions	90	°C
Max. conductor operating temperature at Emergency conditions	130	°C
Max. conductor operating temperature at Short circuit conditions	250	°C
Min. bending radius during installation in terms of cable outer diameter	15 Ø	

The above data is approximate and subject to manufacturing tolerance.

We reserve the right to change the above figures as a result of product development and/or changes in standard.

Constructional Data

Conductor		Insulation			Screen	Armour	Packing			Cable Code
Nominal area of conductor	Approx. conductor diameter	Thickness of insulation layers			Approx. metallic screen tape thickness	Wire diameter	Approx. overall diameter	Approx. overall weight	Standard cutting length $\pm 5\%$	
		C.S	XLPE	I.S						
mm ²	mm	Min.	Nom.	Min.	mm	mm	mm	kg / km	m	
25	5.85	0.3	3.4	0.3	0.076	1.60	24.7	902	1000	C316XH1BBAMRDXXI0MR
35	6.90	0.3	3.4	0.3	0.076	1.60	25.7	1024	1000	C317XH1BBAMRDXXI0MR
50	8.10	0.3	3.4	0.3	0.076	1.60	26.9	1186	1000	C318XH1BBAMRDXXI0MR
70	9.70	0.3	3.4	0.3	0.076	1.60	28.7	1449	1000	C319XH1BBAMRDXXI0MR
95	11.30	0.3	3.4	0.3	0.076	1.60	30.3	1741	1000	C345XH1BBAMRDXXI0MR
120	12.60	0.3	3.4	0.3	0.076	2.00	32.6	2119	1000	C346XH1BBAMRDXXI0MR
150	14.10	0.3	3.4	0.3	0.076	2.00	34.3	2428	1000	C347XH1BBAMRDXXI0MR
185	15.80	0.3	3.4	0.3	0.076	2.00	36.0	2849	1000	C348XH1BBAMRDXXI0MR
240	18.10	0.3	3.4	0.3	0.076	2.00	38.5	3481	1000	C349XH1BBAMRDXXI0MR
300	20.50	0.3	3.4	0.3	0.076	2.00	41.1	4153	1000	C350XH1BBAMRDXXI0MR
400	23.10	0.3	3.4	0.3	0.076	2.50	45.1	5214	1000	C351XH1BBAMRDXXI0MR
500	26.50	0.3	3.4	0.3	0.076	2.50	48.7	6453	500	C352XH1BBAMRDXXI0MF
630	30.05	0.3	3.4	0.3	0.076	2.50	52.7	7869	500	C353XH1BBAMRDXXI0MF
800	34.00	0.3	3.4	0.3	0.076	2.50	57.2	9835	500	C354XH1BBAMRDXXI0MF
1000	40.00	0.3	3.4	0.3	0.076	2.50	65.0	12263	500	C755XH1BBAMRDXXI0MF

Electrical Data

Nominal area of conductor	Electrical Characteristics					Continuous Current Ratings						
	Max. Conductor Resistance		Reactance (60 Hz)	Impedance (90 °C, 60 Hz)	Capacitance	Buried direct in the ground		In single-way ducts		In air		
	DC at 20 °C	AC at 90 °C				Trefoil	Flat spaced	Trefoil	Flat touched	Trefoil	Flat touched	Flat spaced
	mm ²	Ω / km	Ω / km	Ω / km	Ω / km	$\mu\text{F} / \text{km}$	A	A	A	A	A	A
25	0.7270	0.9272	0.185	0.945	0.202	127	131	118	116	148	150	173
35	0.5240	0.6684	0.176	0.691	0.224	152	155	140	138	179	182	208
50	0.3870	0.4938	0.164	0.520	0.249	178	180	164	161	214	217	247
70	0.2680	0.3422	0.155	0.376	0.282	216	214	198	193	265	267	303
95	0.1930	0.2469	0.148	0.288	0.316	256	249	234	225	320	320	361
120	0.1530	0.1961	0.145	0.244	0.343	286	270	260	246	366	361	402
150	0.1240	0.1594	0.140	0.212	0.374	317	292	286	268	413	403	446
185	0.0991	0.1281	0.134	0.186	0.409	353	317	316	293	469	453	495
240	0.0754	0.0985	0.129	0.162	0.456	399	346	353	321	542	514	555
300	0.0601	0.0797	0.125	0.148	0.505	439	369	385	345	611	571	608
400	0.0470	0.0639	0.122	0.138	0.559	473	388	410	362	679	618	661
500	0.0366	0.0518	0.118	0.128	0.629	513	411	442	386	757	676	722
630	0.0283	0.0426	0.114	0.122	0.702	551	434	472	409	835	733	782
800	0.0221	0.0360	0.111	0.117	0.786	583	456	499	429	907	784	841
1000	0.0176	0.0245	0.106	0.109	0.938	626	493	540	465	1022	876	947

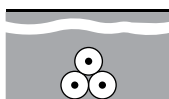

Fig. (a)

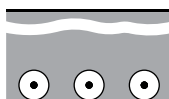

Fig. (b)

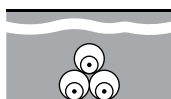

Fig. (c)

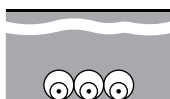

Fig. (d)



Fig. (e)

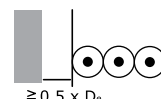

Fig. (f)

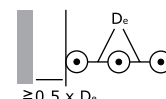

Fig. (g)

Laying Conditions: Ambient air temperature of 40 °C, Ambient ground temperature of 30 °C, Soil thermal resistivity of 1.5 K·m/W, Depth of laying of 0.8 m, and cable screens are bonded at both ends. In case of different laying conditions, appropriate correction (derating) factors from *Annex E* have to be applied to cater for the actual installation conditions.

Three-Core Cables, with Copper Conductors, XLPE Insulated, Wire Armoured and PVC Sheathed

APPLICATION

Suitable for installations indoors: mostly in power supply stations and outdoors: in cable ducts, underground, and on cable trays for industries, switch-boards and power stations. Due to the good laying and mechanical characteristics, this cable is suitable when mechanical protection is required or in applications where mechanical damages are expected to occur.

APPLICABLE STANDARDS

alfanar medium voltage cables are designed and tested to meet or exceed the requirements of IEC 60502-2 standard and/or BS 6622 standard with rated voltage 6.35 / 11 (12) kV. However, **alfanar** can also supply a range of alternative designs to meet customer-specified requirements.

CABLE CONSTRUCTION

Conductor

Plain annealed stranded circular compacted copper conductor (Class 2).

Conductor Screen

Extruded layer of a cross-linkable semi-conducting compound as a stress control layer.

Insulation

Extruded layer of cross-linked polyethylene (XLPE).

Insulation Screen

Extruded layer of a cross-linkable semi-conducting compound firmly bonded to the insulation.

Metallic Screen

Flat plain copper tape helically applied over the insulation screen with suitable overlap.

Filler

Non-hygroscopic polypropylene filler suitable for the operating temperature of the cable.

Bedding

Extruded layer of Polyvinyl chloride (PVC).

Armouring

Single layer of round galvanized steel wires.

Outer Jacket

Extruded layer of Polyvinyl chloride (PVC).

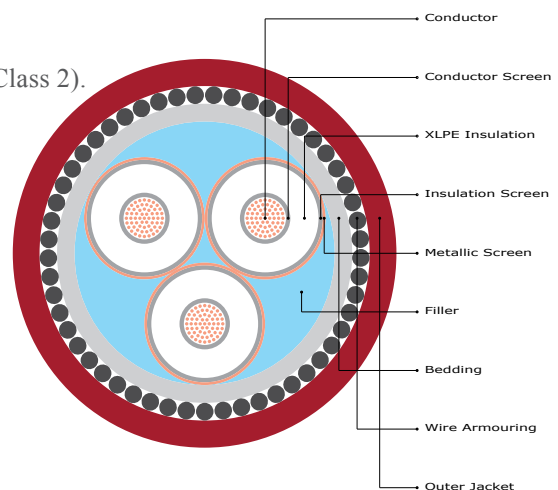

Note: The conductor screen, XLPE insulation and the insulation screen are extruded simultaneously in one process using triple extrusion method (Continuous Vulcanization Line). Triple extrusion method not only assures clean interfaces between the insulation and stress control layers, but also assures a construction free of Partial Discharge with high operational reliability.

TECHNICAL DATA

Rated voltage $U_0 / U (U_m)$	6 / 10	kV
Impulse test voltage (peak value)	75	kV
Power frequency test voltage for 5 minutes	21	kV
Max. conductor operating temperature at Normal conditions	90	°C
Max. conductor operating temperature at Emergency conditions	130	°C
Max. conductor operating temperature at Short circuit conditions	250	°C
Min. bending radius during installation in terms of cable outer diameter	12 \emptyset	

Constructional Data

Conductor		Insulation			Screen	Armour	Packing			Cable Code
Nominal area of conductor	Approx. conductor diameter	Thickness of insulation layers			Approx. metallic screen tape thickness	Wire diameter	Approx. overall diameter	Approx. overall weight	Standard cutting length $\pm 5\%$	
		C.S.	XLPE	I.S.						
mm ²	mm	Min.	Nom.	Min.	mm	mm	mm	kg / km	m	
25	5.85	0.3	3.4	0.3	0.076	2.50	45.5	3933	1000	C316XH3BBWMDXXI0MR
35	6.90	0.3	3.4	0.3	0.076	2.50	47.9	4411	1000	C317XH3BBWMDXXI0MR
50	8.10	0.3	3.4	0.3	0.076	2.50	50.9	5097	1000	C318XH3BBWMDXXI0MR
70	9.70	0.3	3.4	0.3	0.076	2.50	54.7	6044	1000	C319XH3BBWMDXXI0MR
95	11.30	0.3	3.4	0.3	0.076	2.50	58.4	7106	500	C345XH3BBWMDXXI0MF
120	12.60	0.3	3.4	0.3	0.076	2.50	61.6	8135	500	C346XH3BBWMDXXI0MF
150	14.10	0.3	3.4	0.3	0.076	2.50	65.0	9198	500	C347XH3BBWMDXXI0MF
185	15.80	0.3	3.4	0.3	0.076	2.50	69.1	10696	500	C348XH3BBWMDXXI0MF
240	18.10	0.3	3.4	0.3	0.076	3.15	76.6	13834	500	C349XH3BBWMDXXI0MF
300	20.50	0.3	3.4	0.3	0.076	3.15	82.3	16262	400	C350XH3BBWMDXXI0MU
400	23.10	0.3	3.4	0.3	0.076	3.15	88.6	19401	350	C351XH3BBWMDXXI0MV

Electrical Data

Nominal area of conductor	Electrical Characteristics					Continuous Current Ratings		
	Max. Conductor Resistance		Reactance (60 Hz)	Impedance (90 °C, 60 Hz)	Capacitance	Buried direct in the ground	In a buried duct	In air
	DC at 20 °C	AC at 90 °C				Fig. (a)	Fig. (b)	Fig. (c)
mm ²	Ω / km	Ω / km	Ω / km	Ω / km	$\mu F / km$	A	A	A
25	0.7270	0.9272	0.150	0.939	0.202	123	106	135
35	0.5240	0.6685	0.143	0.684	0.224	146	126	163
50	0.3870	0.4939	0.133	0.511	0.249	171	149	193
70	0.2680	0.3425	0.126	0.365	0.282	208	182	238
95	0.1930	0.2472	0.120	0.275	0.316	247	217	287
120	0.1530	0.1966	0.116	0.228	0.343	278	245	327
150	0.1240	0.1601	0.113	0.196	0.374	309	274	369
185	0.0991	0.1289	0.109	0.169	0.409	345	307	417
240	0.0754	0.0997	0.105	0.145	0.456	391	351	482
300	0.0601	0.0812	0.102	0.130	0.505	431	389	541
400	0.0470	0.0659	0.099	0.119	0.559	475	431	606

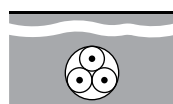

Fig. (a)

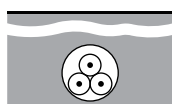

Fig. (b)



Fig. (c)

Laying Conditions: Ambient air temperature of 40 °C, Ambient ground temperature of 30 °C, Soil thermal resistivity of 1.5 K·m/W, Depth of laying of 0.8 m. and cable screens are bonded at both ends. In case of different laying conditions, appropriate correction (derating) factors from *Annex E* have to be applied to cater for the actual installation conditions.

Single-Core Cables, with Aluminum Conductors, XLPE Insulated and PVC Sheathed

APPLICATION

Suitable for installations indoors: mostly in power supply stations and outdoors: in cable ducts, underground, and on cable trays for industries, switch-boards and power stations.

APPLICABLE STANDARDS

alfanar medium voltage cables are designed and tested to meet or exceed the requirements of IEC 60502-2 standard. However, **alfanar** can also supply a range of alternative designs to meet customer-specified requirements.

CABLE CONSTRUCTION

Conductor

Stranded circular compacted aluminum conductor (Class 2).

Conductor Screen

Extruded layer of a cross-linkable semi-conducting compound as a stress control layer.

Insulation

Extruded layer of cross-linked polyethylene (XLPE).

Insulation Screen

Extruded layer of a cross-linkable semi-conducting compound firmly bonded to the insulation.

Metallic Screen

Flat plain copper tape helically applied over the insulation screen with suitable overlap.

Outer Jacket

Extruded layer of Polyvinyl chloride (PVC).

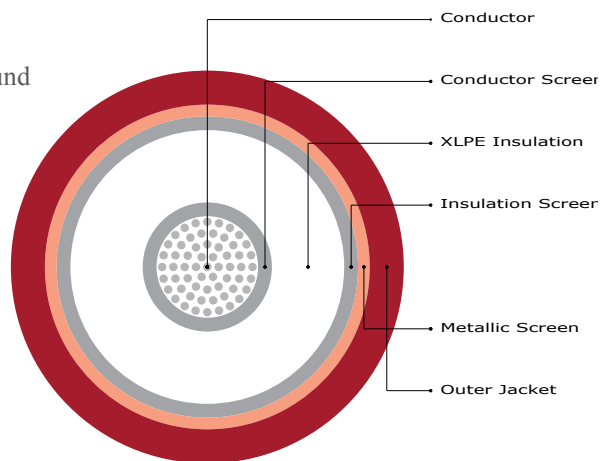

Note: The conductor screen, XLPE insulation and the insulation screen are extruded simultaneously in one process using triple extrusion method (Continuous Vulcanization Line). Triple extrusion method not only assures clean interfaces between the insulation and stress control layers, but also assures a construction free of Partial Discharge with high operational reliability.

TECHNICAL DATA

Rated voltage $U_0 / U (U_m)$	6 / 10 (12)	kV
Impulse test voltage (peak value)	75	kV
Power frequency test voltage for 5 minutes	21	kV
Max. conductor operating temperature at Normal conditions	90	°C
Max. conductor operating temperature at Emergency conditions	130	°C
Max. conductor operating temperature at Short circuit conditions	250	°C
Min. bending radius during installation in terms of cable outer diameter	20 Ø	

The above data is approximate and subject to manufacturing tolerance.

We reserve the right to change the above figures as a result of product development and/or changes in standard.

Constructional Data

Conductor		Insulation			Screen	Armour	Packing			Cable Code
Nominal area of conductor	Approx. conductor diameter	Thickness of insulation layers			Approx. metallic screen tape thickness	N / A	Approx. overall diameter	Approx. overall weight	Standard cutting length $\pm 5\%$	
		C.S	XLPE	I.S						
mm ²	mm	Min.	Nom.	Min.	mm	mm	mm	kg / km	m	
25	5.85	0.3	3.4	0.3	0.076	-	18.2	376	1000	A316XH1BB0MRDXXI0MR
35	6.90	0.3	3.4	0.3	0.076	-	19.2	425	1000	A317XH1BB0MRDXXI0MR
50	8.10	0.3	3.4	0.3	0.076	-	20.4	490	1000	A318XH1BB0MRDXXI0MR
70	9.70	0.3	3.4	0.3	0.076	-	22.2	594	1000	A319XH1BB0MRDXXI0MR
95	11.30	0.3	3.4	0.3	0.076	-	23.8	701	1000	A345XH1BB0MRDXXI0MR
120	12.60	0.3	3.4	0.3	0.076	-	25.3	816	1000	A346XH1BB0MRDXXI0MR
150	14.10	0.3	3.4	0.3	0.076	-	26.8	924	1000	A347XH1BB0MRDXXI0MR
185	15.80	0.3	3.4	0.3	0.076	-	28.7	1083	1000	A348XH1BB0MRDXXI0MR
240	18.10	0.3	3.4	0.3	0.076	-	31.2	1312	1000	A349XH1BB0MRDXXI0MR
300	20.50	0.3	3.4	0.3	0.076	-	33.6	1537	1000	A350XH1BB0MRDXXI0MR
400	23.10	0.3	3.4	0.3	0.076	-	36.6	1870	1000	A351XH1BB0MRDXXI0MR
500	26.50	0.3	3.4	0.3	0.076	-	40.0	2263	1000	A352XH1BB0MRDXXI0MR
630	30.05	0.3	3.4	0.3	0.076	-	44.0	2780	1000	A353XH1BB0MRDXXI0MR
800	34.00	0.3	3.4	0.3	0.076	-	48.3	3446	500	A354XH1BB0MRDXXI0MF
1000	40.00	0.3	3.4	0.3	0.076	-	55.9	4293	500	A755XH1BB0MRDXXI0MF

Electrical Data

Nominal area of conductor	Electrical Characteristics					Continuous Current Ratings						
	Max. Conductor Resistance		Reactance (60 Hz)	Impedance (90 °C, 60 Hz)	Capacitance	Buried direct in the ground		In single-way ducts		In air		
	DC at 20 °C	AC at 90 °C				Trefoil	Flat spaced	Trefoil	Flat touched	Trefoil	Flat touched	Flat spaced
	mm ²	Ω / km	Ω / km	Ω / km	Ω / km	μ F / km	A	A	A	A	A	A
25	1.2000	1.5386	0.162	1.547	0.202	98	102	89	89	108	111	132
35	0.8680	1.1130	0.154	1.124	0.224	117	122	106	106	132	135	161
50	0.6410	0.8221	0.143	0.834	0.249	138	144	126	125	158	162	194
70	0.4430	0.5684	0.136	0.584	0.282	168	176	154	154	198	203	242
95	0.3200	0.4108	0.129	0.431	0.316	201	210	184	184	242	248	295
120	0.2530	0.3251	0.126	0.349	0.343	228	237	210	209	279	286	340
150	0.2060	0.2651	0.122	0.292	0.374	254	266	236	235	318	326	387
185	0.1640	0.2116	0.117	0.242	0.409	287	300	268	267	367	376	446
240	0.1250	0.1621	0.113	0.198	0.456	333	346	311	309	435	446	527
300	0.1000	0.1306	0.109	0.170	0.505	375	389	352	349	503	514	606
400	0.0778	0.1029	0.106	0.148	0.559	427	441	403	398	586	598	703
500	0.0605	0.0819	0.103	0.131	0.629	485	499	461	453	685	697	818
630	0.0469	0.0657	0.100	0.120	0.702	547	560	525	511	793	804	941
800	0.0367	0.0540	0.098	0.112	0.786	610	620	590	570	908	916	1070
1000	0.0291	0.0389	0.095	0.103	0.938	728	703	692	657	1131	1127	1265

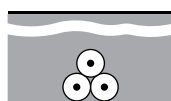

Fig. (a)

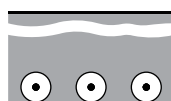

Fig. (b)

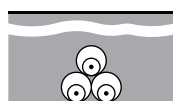

Fig. (c)

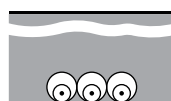

Fig. (d)

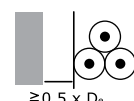

Fig. (e)

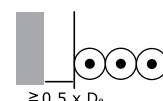

Fig. (f)

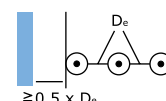

Fig. (g)

Laying Conditions: Ambient air temperature of 40 °C, Ambient ground temperature of 30 °C, Soil thermal resistivity of 1.5 K·m/W, Depth of laying of 0.8 m, and cable screens are bonded at both ends. In case of different laying conditions, appropriate correction (derating) factors from *Annex E* have to be applied to cater for the actual installation conditions.

Three-Core Cables, with Aluminum Conductors, XLPE Insulated and PVC Sheathed

APPLICATION

Suitable for installations indoors: mostly in power supply stations and outdoors: in cable ducts, underground, and on cable trays for industries, switch-boards and power stations.

APPLICABLE STANDARDS

alfanar medium voltage cables are designed and tested to meet or exceed the requirements of IEC 60502-2 standard. However, **alfanar** can also supply a range of alternative designs to meet customer-specified requirements.

CABLE CONSTRUCTION

Conductor

Stranded circular compacted aluminum conductor (Class 2).

Conductor Screen

Extruded layer of a cross-linkable semi-conducting compound as a stress control layer.

Insulation

Extruded layer of cross-linked polyethylene (XLPE).

Insulation Screen

Extruded layer of a cross-linkable semi-conducting compound firmly bonded to the insulation.

Metallic Screen

Flat plain copper tape helically applied over the insulation screen with suitable overlap.

Filler

Non-hygroscopic polypropylene filler suitable for the cable's operating temperature.

Outer Jacket

Extruded layer of Polyvinyl chloride (PVC).

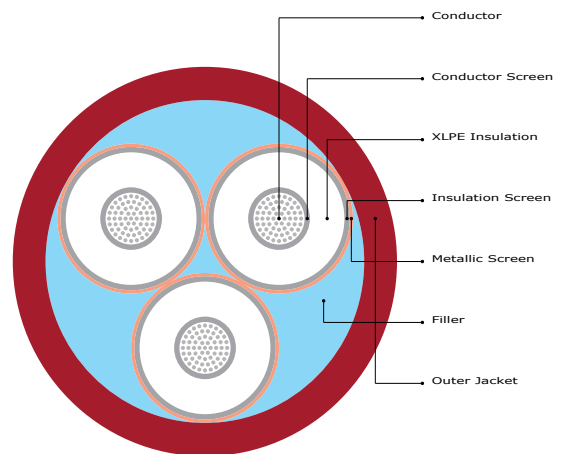

Note: The conductor screen, XLPE insulation and the insulation screen are extruded simultaneously in one process using triple extrusion method (Continuous Vulcanization Line). Triple extrusion method not only assures clean interfaces between the insulation and stress control layers, but also assures a construction free of Partial Discharge with high operational reliability.

TECHNICAL DATA

Rated voltage $U_0 / U (U_m)$	6 / 10 (12)	kV
Impulse test voltage (peak value)	75	kV
Power frequency test voltage for 5 minutes	21	kV
Max. conductor operating temperature at Normal conditions	90	°C
Max. conductor operating temperature at Emergency conditions	130	°C
Max. conductor operating temperature at Short circuit conditions	250	°C
Min. bending radius during installation in terms of cable outer diameter	15 Ø	

The above data is approximate and subject to manufacturing tolerance.

We reserve the right to change the above figures as a result of product development and/or changes in standard.

Constructional Data

Conductor		Insulation			Screen	Armour	Packing			Cable Code
Nominal area of conductor	Approx. conductor diameter	Thickness of insulation layers			Approx. metallic screen tape thickness	N / A	Approx. overall diameter	Approx. overall weight	Standard cutting length $\pm 5\%$	
		C.S	XLPE	I.S						
mm ²	mm	Min.	Nom.	Min.	mm	mm	mm	kg / km	m	
25	5.85	0.3	3.4	0.3	0.076	-	37.3	1262	1000	A316XH3BB0MRDXXI0MR
35	6.90	0.3	3.4	0.3	0.076	-	39.7	1450	1000	A317XH3BB0MRDXXI0MR
50	8.10	0.3	3.4	0.3	0.076	-	42.5	1689	1000	A318XH3BB0MRDXXI0MR
70	9.70	0.3	3.4	0.3	0.076	-	46.1	2031	1000	A319XH3BB0MRDXXI0MR
95	11.30	0.3	3.4	0.3	0.076	-	49.8	2416	1000	A345XH3BB0MRDXXI0MR
120	12.60	0.3	3.4	0.3	0.076	-	52.8	2789	500	A346XH3BB0MRDXXI0MF
150	14.10	0.3	3.4	0.3	0.076	-	56.2	3185	500	A347XH3BB0MRDXXI0MF
185	15.80	0.3	3.4	0.3	0.076	-	60.1	3704	500	A348XH3BB0MRDXXI0MF
240	18.10	0.3	3.4	0.3	0.076	-	65.5	4493	500	A349XH3BB0MRDXXI0MF
300	20.50	0.3	3.4	0.3	0.076	-	71.0	5324	400	A350XH3BB0MRDXXI0MU
400	23.10	0.3	3.4	0.3	0.076	-	77.1	6413	400	A351XH3BB0MRDXXI0MU

Electrical Data

Nominal area of conductor	Electrical Characteristics					Continuous Current Ratings		
	Max. Conductor Resistance		Reactance (60 Hz)	Impedance (90 °C, 60 Hz)	Capacitance	Buried direct in the ground	In a buried duct	In air
	DC at 20 °C	AC at 90 °C				Fig. (a)	Fig. (b)	Fig. (c)
mm ²	Ω / km	Ω / km	Ω / km	Ω / km	$\mu\text{F} / \text{km}$	A	A	A
25	1.2000	1.5386	0.150	1.546	0.202	99	82	109
35	0.8680	1.1131	0.143	0.122	0.224	118	99	132
50	0.6410	0.8221	0.133	0.833	0.249	139	117	158
70	0.4430	0.5684	0.126	0.582	0.282	169	144	197
95	0.3200	0.4110	0.120	0.428	0.316	202	172	240
120	0.2530	0.3253	0.116	0.345	0.343	229	197	276
150	0.2060	0.2653	0.113	0.288	0.374	256	221	313
185	0.1640	0.2118	0.109	0.238	0.409	289	252	361
240	0.1250	0.1624	0.105	0.193	0.456	335	293	425
300	0.1000	0.1311	0.102	0.166	0.505	377	333	488
400	0.0778	0.1036	0.099	0.143	0.559	429	382	566

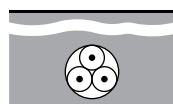

Fig. (a)

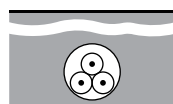

Fig. (b)



Fig. (c)

Laying Conditions: Ambient air temperature of 40 °C, Ambient ground temperature of 30 °C, Soil thermal resistivity of 1.5 K·m/W, Depth of laying of 0.8 m, and cable screens are bonded at both ends. In case of different laying conditions, appropriate correction (derating) factors from *Annex E* have to be applied to cater for the actual installation conditions.

Single-Core Cables, with Aluminum Conductors, XLPE Insulated, Tape Armoured and PVC Sheathed

APPLICATION

Suitable for installations indoors: mostly in power supply stations and outdoors: in cable ducts, underground, and on cable trays for industries, switch-boards and power stations. Due to the good laying and mechanical characteristics, this cable is suitable when mechanical protection is required or in applications where mechanical damages are expected to occur.

APPLICABLE STANDARDS

alfanar medium voltage cables are designed and tested to meet or exceed the requirements of IEC 60502-2 standard. However, **alfanar** can also supply a range of alternative designs to meet customer-specified requirements.

CABLE CONSTRUCTION

Conductor

Stranded circular compacted aluminum conductor (Class 2).

Conductor Screen

Extruded layer of a cross-linkable semi-conducting compound as a stress control layer.

Insulation

Extruded layer of cross-linked polyethylene (XLPE).

Insulation Screen

Extruded layer of a cross-linkable semi-conducting compound firmly bonded to the insulation.

Metallic Screen

Flat plain copper tape helically applied over the insulation screen with suitable overlap.

Bedding

Extruded layer of Polyvinyl chloride (PVC).

Armouring

Double layer of non-magnetic (aluminum) tapes.

Outer Jacket

Extruded layer of Polyvinyl chloride (PVC).

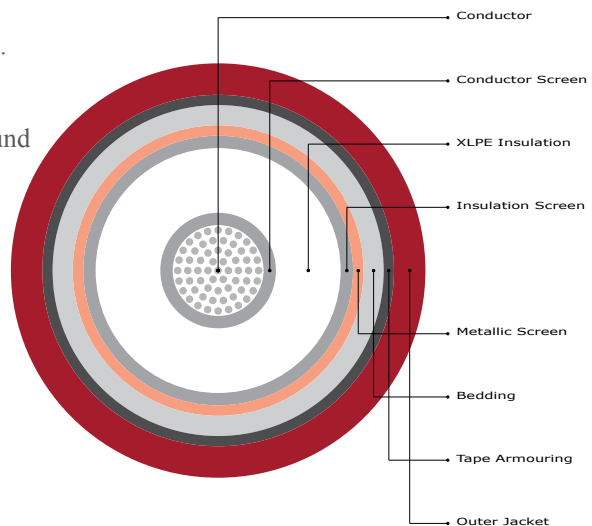

Note: The conductor screen, XLPE insulation and the insulation screen are extruded simultaneously in one process using triple extrusion method (Continuous Vulcanization Line). Triple extrusion method not only assures clean interfaces between the insulation and stress control layers, but also assures a construction free of Partial Discharge with high operational reliability.

TECHNICAL DATA

Rated voltage $U_0 / U (U_m)$	6 / 10 (12)	kV
Impulse test voltage (peak value)	75	kV
Power frequency test voltage for 5 minutes	21	kV
Max. conductor operating temperature at Normal conditions	90	°C
Max. conductor operating temperature at Emergency conditions	130	°C
Max. conductor operating temperature at Short circuit conditions	250	°C
Min. bending radius during installation in terms of cable outer diameter	15 Ø	

The above data is approximate and subject to manufacturing tolerance.

We reserve the right to change the above figures as a result of product development and/or changes in standard.

Constructional Data

Conductor		Insulation			Screen	Armour	Packing			Cable Code
Nominal area of conductor	Approx. conductor diameter	Thickness of insulation layers			Approx. metallic screen tape thickness	Tape thickness	Approx. overall diameter	Approx. overall weight	Standard cutting length $\pm 5\%$	
		C.S	XLPE	I.S						
mm ²	mm	Min.	Nom.	Min.	mm	mm	mm	kg / km	m	
25	5.85	0.3	3.4	0.3	0.076	0.50	22.8	624	1000	A316XH1BBBMRDXXI0MR
35	6.90	0.3	3.4	0.3	0.076	0.50	23.8	686	1000	A317XH1BBBMRDXXI0MR
50	8.10	0.3	3.4	0.3	0.076	0.50	25.2	776	1000	A318XH1BBBMRDXXI0MR
70	9.70	0.3	3.4	0.3	0.076	0.50	26.8	892	1000	A319XH1BBBMRDXXI0MR
95	11.30	0.3	3.4	0.3	0.076	0.50	28.6	1031	1000	A345XH1BBBMRDXXI0MR
120	12.60	0.3	3.4	0.3	0.076	0.50	29.9	1150	1000	A346XH1BBBMRDXXI0MR
150	14.10	0.3	3.4	0.3	0.076	0.50	31.6	1292	1000	A347XH1BBBMRDXXI0MR
185	15.80	0.3	3.4	0.3	0.076	0.50	33.5	1475	1000	A348XH1BBBMRDXXI0MR
240	18.10	0.3	3.4	0.3	0.076	0.50	35.8	1718	1000	A349XH1BBBMRDXXI0MR
300	20.50	0.3	3.4	0.3	0.076	0.50	38.4	1991	1000	A350XH1BBBMRDXXI0MR
400	23.10	0.3	3.4	0.3	0.076	0.50	41.4	2362	1000	A351XH1BBBMRDXXI0MR
500	26.50	0.3	3.4	0.3	0.076	0.50	45.0	2820	1000	A352XH1BBBMRDXXI0MR
630	30.05	0.3	3.4	0.3	0.076	0.50	49.0	3389	1000	A353XH1BBBMRDXXI0MR
800	34.00	0.3	3.4	0.3	0.076	0.50	53.3	4112	500	A354XH1BBBMRDXXI0MF
1000	40.00	0.3	3.4	0.3	0.076	0.50	61.3	5119	500	A755XH1BBBMRDXXI0MF

Electrical Data

Nominal area of conductor	Electrical Characteristics					Continuous Current Ratings						
	Max. Conductor Resistance		Reactance (60 Hz)	Impedance (90 °C, 60 Hz)	Capacitance	Buried direct in the ground		In single-way ducts		In air		
	DC at 20 °C	AC at 90 °C				Trefoil	Flat spaced	Trefoil	Flat touched	Trefoil	Flat touched	Flat spaced
	mm ²	Ω / km	Ω / km	Ω / km	Ω / km	μ F / km	A	A	A	A	A	A
25	1.2000	1.5386	0.179	1.549	0.202	98	103	90	91	112	114	133
35	0.8680	1.1130	0.170	1.126	0.224	117	122	108	108	135	139	161
50	0.6410	0.8220	0.159	0.837	0.249	138	143	128	127	163	166	193
70	0.4430	0.5683	0.150	0.588	0.282	168	175	156	156	203	207	241
95	0.3200	0.4108	0.143	0.435	0.316	201	208	187	185	246	252	292
120	0.2530	0.3250	0.138	0.353	0.343	227	235	212	210	284	290	335
150	0.2060	0.2650	0.134	0.297	0.374	254	261	237	235	323	329	380
185	0.1640	0.2114	0.129	0.248	0.409	287	294	269	265	371	378	435
240	0.1250	0.1618	0.124	0.204	0.456	331	337	311	305	439	445	510
300	0.1000	0.1303	0.119	0.177	0.505	374	376	350	342	505	511	582
400	0.0778	0.1025	0.116	0.155	0.559	424	422	399	387	586	590	668
500	0.0605	0.0813	0.112	0.138	0.629	481	472	454	436	682	683	768
630	0.0469	0.0650	0.109	0.126	0.702	540	513	508	479	785	775	858
800	0.0367	0.0532	0.106	0.118	0.786	597	549	560	517	891	867	944
1000	0.0291	0.0387	0.102	0.109	0.938	694	593	635	569	1078	1022	1063

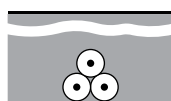

Fig. (a)

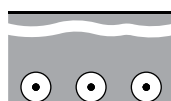

Fig. (b)

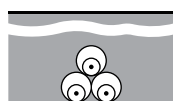

Fig. (c)

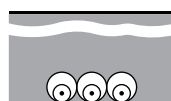

Fig. (d)

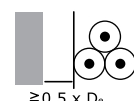

Fig. (e)

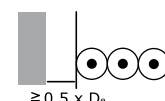

Fig. (f)

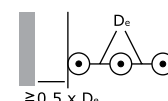

Fig. (g)

Laying Conditions: Ambient air temperature of 40 °C, Ambient ground temperature of 30 °C, Soil thermal resistivity of 1.5 K·m/W, Depth of laying of 0.8 m, and cable screens are bonded at both ends. In case of different laying conditions, appropriate correction (derating) factors from *Annex E* have to be applied to cater for the actual installation conditions.

Three-Core Cables, with Aluminum Conductors, XLPE Insulated, Tape Armoured and PVC Sheathed

APPLICATION

Suitable for installations indoors: mostly in power supply stations and outdoors: in cable ducts, underground, and on cable trays for industries, switch-boards and power stations. Due to the good laying and mechanical characteristics, this cable is suitable when mechanical protection is required or in applications where mechanical damages are expected to occur.

APPLICABLE STANDARDS

alfanar medium voltage cables are designed and tested to meet or exceed the requirements of IEC 60502-2 standard. However, **alfanar** can also supply a range of alternative designs to meet customer-specified requirements.

CABLE CONSTRUCTION

Conductor

Stranded circular compacted aluminum conductor (Class 2).

Conductor Screen

Extruded layer of a cross-linkable semi-conducting compound as a stress control layer.

Insulation

Extruded layer of cross-linked polyethylene (XLPE).

Insulation Screen

Extruded layer of a cross-linkable semi-conducting compound firmly bonded to the insulation.

Metallic Screen

Flat plain copper tape helically applied over the insulation screen with suitable overlap.

Filler

Non-hygroscopic polypropylene filler suitable for the cable's operating temperature.

Bedding

Extruded layer of Polyvinyl chloride (PVC).

Armouring

Double layer of galvanized steel tapes.

Outer Jacket

Extruded layer of Polyvinyl chloride (PVC).

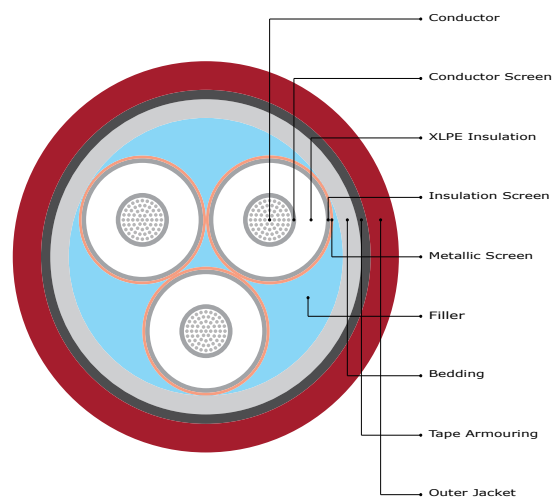

Note: The conductor screen, XLPE insulation and the insulation screen are extruded simultaneously in one process using triple extrusion method (Continuous Vulcanization Line). Triple extrusion method not only assures clean interfaces between the insulation and stress control layers, but also assures a construction free of Partial Discharge with high operational reliability.

TECHNICAL DATA

Rated voltage $U_0 / U (U_m)$	6 / 10 (12)	kV
Impulse test voltage (peak value)	75	kV
Power frequency test voltage for 5 minutes	21	kV
Max. conductor operating temperature at Normal conditions	90	°C
Max. conductor operating temperature at Emergency conditions	130	°C
Max. conductor operating temperature at Short circuit conditions	250	°C
Min. bending radius during installation in terms of cable outer diameter	12 \emptyset	

Constructional Data

Conductor		Insulation			Screen	Armour	Packing			Cable Code
Nominal area of conductor	Approx. conductor diameter	Thickness of insulation layers			Approx. metallic screen tape thickness	Tape thickness	Approx. overall diameter	Approx. overall weight	Standard cutting length $\pm 5\%$	
		C.S.	XLPE	I.S.						
mm ²	mm	Min.	Nom.	Min.	mm	mm	mm	kg / km	m	
25	5.85	0.3	3.4	0.3	0.076	0.50	42.3	2176	1000	A316XH3BBGMRDXXI0MR
35	6.90	0.3	3.4	0.3	0.076	0.50	44.5	2398	1000	A317XH3BBGMRDXXI0MR
50	8.10	0.3	3.4	0.3	0.076	0.50	47.7	2749	1000	A318XH3BBGMRDXXI0MR
70	9.70	0.3	3.4	0.3	0.076	0.50	51.5	3204	1000	A319XH3BBGMRDXXI0MR
95	11.30	0.3	3.4	0.3	0.076	0.50	55.2	3679	500	A345XH3BBGMRDXXI0MF
120	12.60	0.3	3.4	0.3	0.076	0.50	58.4	4155	500	A346XH3BBGMRDXXI0MF
150	14.10	0.3	3.4	0.3	0.076	0.50	61.8	4635	500	A347XH3BBGMRDXXI0MF
185	15.80	0.3	3.4	0.3	0.076	0.50	65.9	5286	500	A348XH3BBGMRDXXI0MF
240	18.10	0.3	3.4	0.3	0.076	0.50	71.5	6248	500	A349XH3BBGMRDXXI0MF
300	20.50	0.3	3.4	0.3	0.076	0.50	77.2	7260	500	A350XH3BBGMRDXXI0MF
400	23.10	0.3	3.4	0.3	0.076	0.80	84.7	9333	400	A351XH3BBGMRDXXI0MU

Electrical Data

Nominal area of conductor	Electrical Characteristics					Continuous Current Ratings		
	Max. Conductor Resistance		Reactance (60 Hz)	Impedance (90 °C, 60 Hz)	Capacitance	Buried direct in the ground	In a buried duct	In air
	DC at 20 °C	AC at 90 °C				Fig. (a)	Fig. (b)	Fig. (c)
mm ²	Ω / km	Ω / km	Ω / km	Ω / km	$\mu\text{F} / \text{km}$	A	A	A
25	1.2000	1.5386	0.150	1.546	0.202	95	81	103
35	0.8680	1.1131	0.143	1.122	0.224	113	97	124
50	0.6410	0.8221	0.133	0.833	0.249	133	114	147
70	0.4430	0.5684	0.126	0.582	0.282	162	140	183
95	0.3200	0.4110	0.120	0.428	0.316	192	168	221
120	0.2530	0.3253	0.116	0.345	0.343	218	191	253
150	0.2060	0.2653	0.113	0.288	0.374	244	215	287
185	0.1640	0.2118	0.109	0.238	0.409	275	244	328
240	0.1250	0.1624	0.105	0.193	0.456	318	284	385
300	0.1000	0.1311	0.102	0.166	0.505	357	321	439
400	0.0778	0.1036	0.099	0.143	0.559	406	368	508

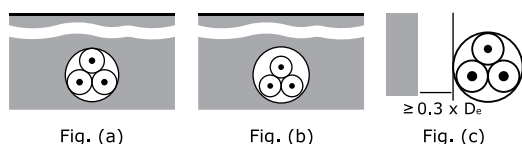

Laying Conditions: Ambient air temperature of 40 °C, Ambient ground temperature of 30 °C, Soil thermal resistivity of 1.5 K·m/W, Depth of laying of 0.8 m. and cable screens are bonded at both ends. In case of different laying conditions, appropriate correction (derating) factors from *Annex E* have to be applied to cater for the actual installation conditions.

Single-Core Cables, with Aluminum Conductors, XLPE Insulated, Wire Armoured and PVC Sheathed

APPLICATION

Suitable for installations indoors: mostly in power supply stations and outdoors: in cable ducts, underground, and on cable trays for industries, switch-boards and power stations. Due to the good laying and mechanical characteristics, this cable is suitable when mechanical protection is required or in applications where mechanical damages are expected to occur.

APPLICABLE STANDARDS

alfanar medium voltage cables are designed and tested to meet or exceed the requirements of IEC 60502-2 standard and/or BS 6622 standard with rated voltage 6.35 / 11 (12) kV. However, **alfanar** can also supply a range of alternative designs to meet customer-specified requirements

CABLE CONSTRUCTION

Conductor

Stranded circular compacted aluminum conductor (Class 2).

Conductor Screen

Extruded layer of a cross-linkable semi-conducting compound as a stress control layer.

Insulation

Extruded layer of cross-linked polyethylene (XLPE).

Insulation Screen

Extruded layer of a cross-linkable semi-conducting compound firmly bonded to the insulation.

Metallic Screen

Flat plain copper tape helically applied over the insulation screen with suitable overlap.

Bedding

Extruded layer of Polyvinyl chloride (PVC).

Armouring

Single layer of round non-magnetic (aluminum) wires.

Outer Jacket

Extruded layer of Polyvinyl chloride (PVC).

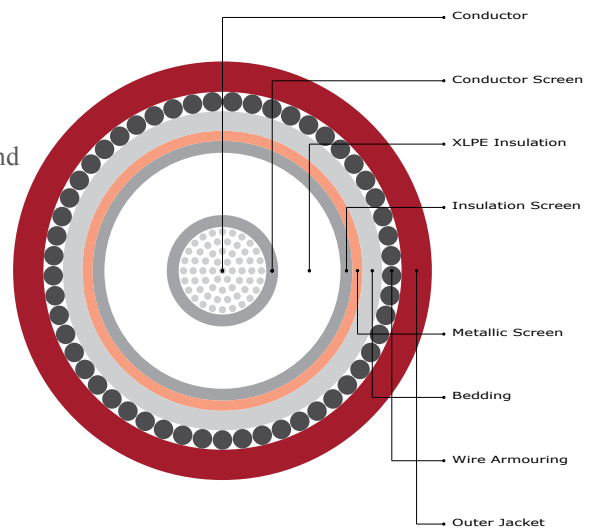

Note: The conductor screen, XLPE insulation and the insulation screen are extruded simultaneously in one process using triple extrusion method (Continuous Vulcanization Line). Triple extrusion method not only assures clean interfaces between the insulation and stress control layers, but also assures a construction free of Partial Discharge with high operational reliability.

TECHNICAL DATA

Rated voltage $U_0 / U (U_m)$	6 / 10 (12)	kV
Impulse test voltage (peak value)	75	kV
Power frequency test voltage for 5 minutes	21	kV
Max. conductor operating temperature at Normal conditions	90	°C
Max. conductor operating temperature at Emergency conditions	130	°C
Max. conductor operating temperature at Short circuit conditions	250	°C
Min. bending radius during installation in terms of cable outer diameter	15 Ø	

The above data is approximate and subject to manufacturing tolerance.

We reserve the right to change the above figures as a result of product development and/or changes in standard.

Constructional Data

Conductor		Insulation			Screen	Armour	Packing			Cable Code
Nominal area of conductor	Approx. conductor diameter	Thickness of insulation layers			Approx. metallic screen tape thickness	Wire diameter	Approx. overall diameter	Approx. overall weight	Standard cutting length $\pm 5\%$	
		C.S	XLPE	I.S						
mm ²	mm	Min.	Nom.	Min.	mm	mm	mm	kg / km	m	
25	5.85	0.3	3.4	0.3	0.076	1.60	24.7	748	1000	A316XH1BBAMRDXXI0MR
35	6.90	0.3	3.4	0.3	0.076	1.60	25.7	810	1000	A317XH1BBAMRDXXI0MR
50	8.10	0.3	3.4	0.3	0.076	1.60	26.9	894	1000	A318XH1BBAMRDXXI0MR
70	9.70	0.3	3.4	0.3	0.076	1.60	28.7	1031	1000	A319XH1BBAMRDXXI0MR
95	11.30	0.3	3.4	0.3	0.076	1.60	30.3	1166	1000	A345XH1BBAMRDXXI0MR
120	12.60	0.3	3.4	0.3	0.076	2.00	32.6	1388	1000	A346XH1BBAMRDXXI0MR
150	14.10	0.3	3.4	0.3	0.076	2.00	34.3	1542	1000	A347XH1BBAMRDXXI0MR
185	15.80	0.3	3.4	0.3	0.076	2.00	36.0	1718	1000	A348XH1BBAMRDXXI0MR
240	18.10	0.3	3.4	0.3	0.076	2.00	38.5	2004	1000	A349XH1BBAMRDXXI0MR
300	20.50	0.3	3.4	0.3	0.076	2.00	41.1	2293	1000	A350XH1BBAMRDXXI0MR
400	23.10	0.3	3.4	0.3	0.076	2.50	45.1	2824	1000	A351XH1BBAMRDXXI0MR
500	26.50	0.3	3.4	0.3	0.076	2.50	48.7	3323	1000	A352XH1BBAMRDXXI0MR
630	30.05	0.3	3.4	0.3	0.076	2.50	52.7	3933	1000	A353XH1BBAMRDXXI0MR
800	34.00	0.3	3.4	0.3	0.076	2.50	57.2	4735	500	A354XH1BBAMRDXXI0MF
1000	40.00	0.3	3.4	0.3	0.076	2.50	65.0	5808	500	A755XH1BBAMRDXXI0MF

Electrical Data

Nominal area of conductor	Electrical Characteristics					Continuous Current Ratings						
	Max. Conductor Resistance		Reactance (60 Hz)	Impedance (90 °C, 60 Hz)	Capacitance	Buried direct in the ground		In single-way ducts		In air		
	DC at 20 °C	AC at 90 °C				Trefoil	Flat spaced	Trefoil	Flat touched	Trefoil	Flat touched	Flat spaced
	mm ²	Ω / km	Ω / km	Ω / km	Ω / km	$\mu\text{F} / \text{km}$	A	A	A	A	A	A
25	1.2000	1.5386	0.185	1.550	0.202	99	103	92	91	115	117	135
35	0.8680	1.1130	0.176	1.127	0.224	118	121	109	108	139	142	163
50	0.6410	0.8220	0.164	0.838	0.249	139	142	128	127	166	169	194
70	0.4430	0.5683	0.155	0.589	0.282	169	171	156	153	207	210	240
95	0.3200	0.4107	0.148	0.436	0.316	200	200	185	180	250	252	288
120	0.2530	0.3250	0.145	0.356	0.343	225	221	208	200	288	288	326
150	0.2060	0.2649	0.140	0.300	0.374	251	242	230	220	326	324	364
185	0.1640	0.2113	0.134	0.250	0.409	281	266	257	244	372	368	409
240	0.1250	0.1617	0.129	0.207	0.456	321	296	291	272	435	424	467
300	0.1000	0.1301	0.125	0.180	0.505	357	320	322	297	495	477	520
400	0.0778	0.1022	0.122	0.159	0.559	394	344	351	320	562	530	577
500	0.0605	0.0809	0.118	0.143	0.629	437	372	386	347	640	593	643
630	0.0469	0.0646	0.114	0.131	0.702	479	399	421	374	721	656	709
800	0.0367	0.0527	0.111	0.123	0.786	518	425	453	399	800	715	775
1000	0.0291	0.0386	0.106	0.113	0.938	561	463	495	435	908	805	878

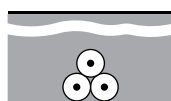

Fig. (a)

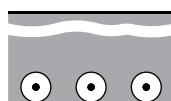

Fig. (b)

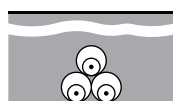

Fig. (c)

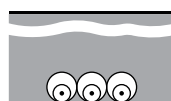

Fig. (d)

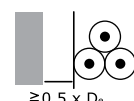

Fig. (e)

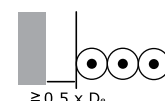

Fig. (f)

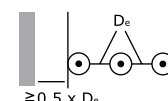

Fig. (g)

Laying Conditions: Ambient air temperature of 40 °C, Ambient ground temperature of 30 °C, Soil thermal resistivity of 1.5 K·m/W, Depth of laying of 0.8 m, and cable screens are bonded at both ends. In case of different laying conditions, appropriate correction (derating) factors from *Annex E* have to be applied to cater for the actual installation conditions.

Three-Core Cables, with Aluminum Conductors, XLPE Insulated, Wire Armoured and PVC Sheathed

APPLICATION

Suitable for installations indoors: mostly in power supply stations and outdoors: in cable ducts, underground, and on cable trays for industries, switch-boards and power stations. Due to the good laying and mechanical characteristics, this cable is suitable when mechanical protection is required or in applications where mechanical damages are expected to occur.

APPLICABLE STANDARDS

alfanar medium voltage cables are designed and tested to meet or exceed the requirements of IEC 60502-2 standard and/or BS 6622 standard with rated voltage 6.35 / 11 (12) kV. However, **alfanar** can also supply a range of alternative designs to meet customer-specified requirements.

CABLE CONSTRUCTION

Conductor

Stranded circular compacted aluminum conductor (Class 2).

Conductor Screen

Extruded layer of a cross-linkable semi-conducting compound as a stress control layer.

Insulation

Extruded layer of cross-linked polyethylene (XLPE).

Insulation Screen

Extruded layer of a cross-linkable semi-conducting compound firmly bonded to the insulation.

Metallic Screen

Flat plain copper tape helically applied over the insulation screen with suitable overlap.

Filler

Non-hygroscopic polypropylene filler suitable for the cable's operating temperature.

Bedding

Extruded layer of Polyvinyl chloride (PVC).

Armouring

Single layer of round galvanized steel wires.

Outer Jacket

Extruded layer of Polyvinyl chloride (PVC).

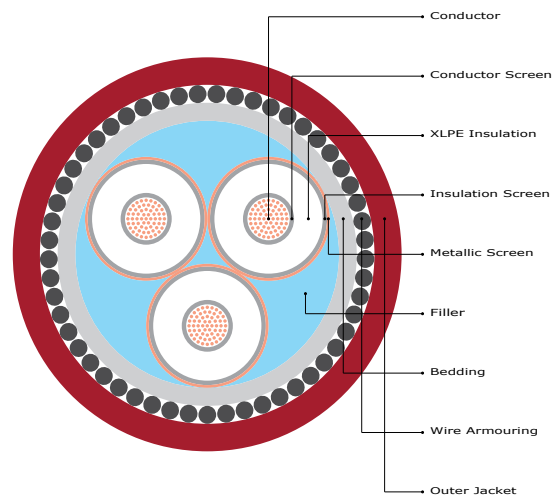

Note: The conductor screen, XLPE insulation and the insulation screen are extruded simultaneously in one process using triple extrusion method (Continuous Vulcanization Line). Triple extrusion method not only assures clean interfaces between the insulation and stress control layers, but also assures a construction free of Partial Discharge with high operational reliability.

TECHNICAL DATA

Rated voltage $U_0 / U (U_m)$	6 / 10 (12)	kV
Impulse test voltage (peak value)	75	kV
Power frequency test voltage for 5 minutes	21	kV
Max. conductor operating temperature at Normal conditions	90	°C
Max. conductor operating temperature at Emergency conditions	130	°C
Max. conductor operating temperature at Short circuit conditions	250	°C
Min. bending radius during installation in terms of cable outer diameter	12 \emptyset	

Constructional Data

Conductor		Insulation			Screen	Armour	Packing			Cable Code
Nominal area of conductor	Approx. conductor diameter	Thickness of insulation layers			Approx. metallic screen tape thickness	Wire diameter	Approx. overall diameter	Approx. overall weight	Standard cutting length $\pm 5\%$	
		C.S.	XLPE	I.S.						
mm ²	mm	Min.	Nom.	Min.	mm	mm	mm	kg / km	m	
25	5.85	0.3	3.4	0.3	0.076	2.50	45.5	3471	1000	A316XH3BBWMDXXI0MR
35	6.90	0.3	3.4	0.3	0.076	2.50	47.9	3769	1000	A317XH3BBWMDXXI0MR
50	8.10	0.3	3.4	0.3	0.076	2.50	50.9	4220	1000	A318XH3BBWMDXXI0MR
70	9.70	0.3	3.4	0.3	0.076	2.50	54.7	4790	1000	A319XH3BBWMDXXI0MR
95	11.30	0.3	3.4	0.3	0.076	2.50	58.4	5381	500	A345XH3BBWMDXXI0MF
120	12.60	0.3	3.4	0.3	0.076	2.50	61.6	5942	500	A346XH3BBWMDXXI0MF
150	14.10	0.3	3.4	0.3	0.076	2.50	65.0	6540	500	A347XH3BBWMDXXI0MF
185	15.80	0.3	3.4	0.3	0.076	2.50	69.1	7303	500	A348XH3BBWMDXXI0MF
240	18.10	0.3	3.4	0.3	0.076	3.15	76.6	9403	500	A349XH3BBWMDXXI0MF
300	20.50	0.3	3.4	0.3	0.076	3.15	82.3	10682	500	A350XH3BBWMDXXI0MF
400	23.10	0.3	3.4	0.3	0.076	3.15	88.6	12231	400	A351XH3BBWMDXXI0MU

Electrical Data

Nominal area of conductor	Electrical Characteristics					Continuous Current Ratings		
	Max. Conductor Resistance		Reactance (60 Hz)	Impedance (90 °C, 60 Hz)	Capacitance	Buried direct in the ground	In a buried duct	In air
	DC at 20 °C	AC at 90 °C				Fig. (a)	Fig. (b)	Fig. (c)
mm ²	Ω / km	Ω / km	Ω / km	Ω / km	$\mu\text{F} / \text{km}$	A	A	A
25	1.2000	1.5386	0.150	1.546	0.202	96	82	105
35	0.8680	1.1131	0.143	1.122	0.224	114	98	126
50	0.6410	0.8221	0.133	0.833	0.249	133	116	150
70	0.4430	0.5684	0.126	0.582	0.282	162	142	185
95	0.3200	0.4110	0.120	0.428	0.316	193	169	224
120	0.2530	0.3253	0.116	0.345	0.343	217	192	256
150	0.2060	0.2653	0.113	0.288	0.374	243	215	289
185	0.1640	0.2118	0.109	0.238	0.409	273	243	329
240	0.1250	0.1624	0.105	0.193	0.456	312	280	384
300	0.1000	0.1311	0.102	0.166	0.505	348	314	434
400	0.0778	0.1036	0.099	0.143	0.559	390	354	495

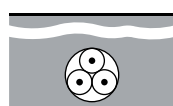

Fig. (a)

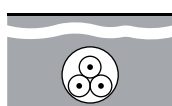

Fig. (b)



Fig. (c)

Laying Conditions: Ambient air temperature of 40 °C, Ambient ground temperature of 30 °C, Soil thermal resistivity of 1.5 K·m/W, Depth of laying of 0.8 m. and cable screens are bonded at both ends. In case of different laying conditions, appropriate correction (derating) factors from *Annex E* have to be applied to cater for the actual installation conditions.

Single-Core Cables, with Copper Conductors, XLPE Insulated and PVC Sheathed

APPLICATION

Suitable for installations indoors: mostly in power supply stations and outdoors: in cable ducts, underground, and on cable trays for industries, switch-boards and power stations.

APPLICABLE STANDARDS

alfanar medium voltage cables are designed and tested to meet or exceed the requirements of IEC 60502-2 standard. However, **alfanar** can also supply a range of alternative designs to meet customer-specified requirements.

CABLE CONSTRUCTION

Conductor

Plain annealed stranded circular compacted copper conductor (Class 2).

Conductor Screen

Extruded layer of a cross-linkable semi-conducting compound as a stress control layer.

Insulation

Extruded layer of cross-linked polyethylene (XLPE).

Insulation Screen

Extruded layer of a cross-linkable semi-conducting compound firmly bonded to the insulation.

Metallic Screen

Flat plain copper tape helically applied over the insulation screen with suitable overlap.

Outer Jacket

Extruded layer of Polyvinyl chloride (PVC).

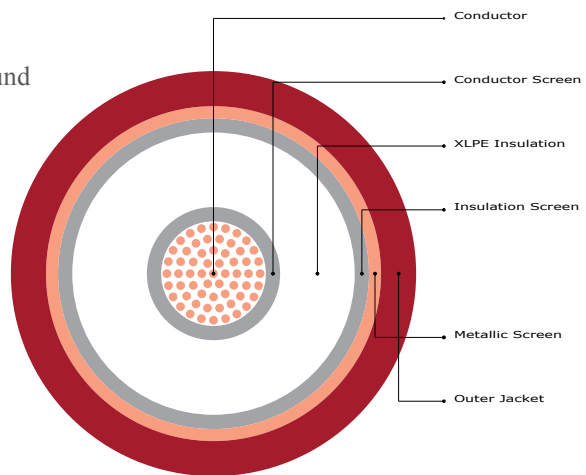

Note: The conductor screen, XLPE insulation and the insulation screen are extruded simultaneously in one process using triple extrusion method (Continuous Vulcanization Line). Triple extrusion method not only assures clean interfaces between the insulation and stress control layers, but also assures a construction free of Partial Discharge with high operational reliability.

TECHNICAL DATA

Rated voltage $U_0 / U (U_m)$	8.7 / 15 (17.5)	kV
Impulse test voltage (peak value)	95	kV
Power frequency test voltage for 5 minutes	30.5	kV
Max. conductor operating temperature at Normal conditions	90	°C
Max. conductor operating temperature at Emergency conditions	130	°C
Max. conductor operating temperature at Short circuit conditions	250	°C
Min. bending radius during installation in terms of cable outer diameter	20 Ø	

The above data is approximate and subject to manufacturing tolerance.

We reserve the right to change the above figures as a result of product development and/or changes in standard.

Constructional Data

Conductor		Insulation			Screen	Armour	Packing			Cable Code
Nominal area of conductor	Approx. conductor diameter	Thickness of insulation layers			Approx. metallic screen tape thickness	N / A	Approx. overall diameter	Approx. overall weight	Standard cutting length $\pm 5\%$	
		C.S	XLPE	I.S						
mm ²	mm	Min.	Nom.	Min.	mm	mm	mm	kg / km	m	
25	5.85	0.3	4.5	0.3	0.076	-	20.4	606	1000	C316XJ1BB0MRDXXI0MR
35	6.90	0.3	4.5	0.3	0.076	-	21.6	729	1000	C317XJ1BB0MRDXXI0MR
50	8.10	0.3	4.5	0.3	0.076	-	22.8	874	1000	C318XJ1BB0MRDXXI0MR
70	9.70	0.3	4.5	0.3	0.076	-	24.6	1113	1000	C319XJ1BB0MRDXXI0MR
95	11.30	0.3	4.5	0.3	0.076	-	26.2	1382	1000	C345XJ1BB0MRDXXI0MR
120	12.60	0.3	4.5	0.3	0.076	-	27.7	1661	1000	C346XJ1BB0MRDXXI0MR
150	14.10	0.3	4.5	0.3	0.076	-	29.2	1930	1000	C347XJ1BB0MRDXXI0MR
185	15.80	0.3	4.5	0.3	0.076	-	31.1	2341	1000	C348XJ1BB0MRDXXI0MR
240	18.10	0.3	4.5	0.3	0.076	-	33.6	2924	1000	C349XJ1BB0MRDXXI0MR
300	20.50	0.3	4.5	0.3	0.076	-	36.0	3542	1000	C350XJ1BB0MRDXXI0MR
400	23.10	0.3	4.5	0.3	0.076	-	38.8	4398	1000	C351XJ1BB0MRDXXI0MR
500	26.50	0.3	4.5	0.3	0.076	-	42.4	5563	500	C352XJ1BB0MRDXXI0MF
630	30.05	0.3	4.5	0.3	0.076	-	46.2	6878	500	C353XJ1BB0MRDXXI0MF
800	34.00	0.3	4.5	0.3	0.076	-	50.7	8748	500	C354XJ1BB0MRDXXI0MF
1000	40.00	0.3	4.5	0.3	0.076	-	58.3	10981	500	C755XJ1BB0MRDXXI0MF

Electrical Data

Nominal area of conductor	Electrical Characteristics					Continuous Current Ratings						
	Max. Conductor Resistance		Reactance (60 Hz)	Impedance (90 °C, 60 Hz)	Capacitance	Buried direct in the ground		In single-way ducts		In air		
	DC at 20 °C	AC at 90 °C				Trefoil	Flat spaced	Trefoil	Flat touched	Trefoil	Flat touched	Flat spaced
	mm ²	Ω / km	Ω / km	Ω / km	Ω / km	$\mu\text{F} / \text{km}$	A	A	A	A	A	A
25	0.7270	0.9272	0.171	0.943	0.166	126	132	114	114	140	111	132
35	0.5240	0.6684	0.163	0.688	0.183	151	157	137	137	170	135	161
50	0.3870	0.4938	0.151	0.516	0.202	178	185	162	162	204	162	194
70	0.2680	0.3423	0.143	0.371	0.228	217	226	198	198	255	203	242
95	0.1930	0.2470	0.137	0.282	0.253	259	269	238	237	311	248	295
120	0.1530	0.1962	0.133	0.237	0.273	293	304	270	269	359	286	340
150	0.1240	0.1596	0.128	0.205	0.297	327	340	303	301	409	326	387
185	0.0991	0.1283	0.123	0.178	0.324	368	382	343	340	470	376	446
240	0.0754	0.0989	0.119	0.155	0.360	425	439	397	393	556	446	527
300	0.0601	0.0802	0.115	0.140	0.397	476	491	448	441	638	514	606
400	0.0470	0.0646	0.111	0.128	0.438	535	550	508	497	735	598	703
500	0.0366	0.0527	0.107	0.119	0.491	599	612	573	557	846	697	818
630	0.0283	0.0436	0.104	0.113	0.546	664	675	643	618	963	804	941
800	0.0221	0.0371	0.102	0.108	0.610	725	733	709	676	1081	916	1070
1000	0.0176	0.0248	0.098	0.101	0.725	891	829	842	782	1387	1127	1265

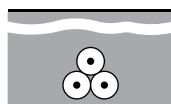

Fig. (a)

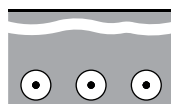

Fig. (b)

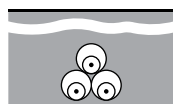

Fig. (c)

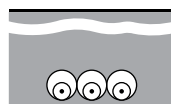

Fig. (d)

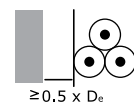

Fig. (e)



Fig. (f)

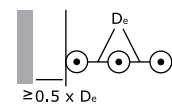

Fig. (g)

Laying Conditions: Ambient air temperature of 40 °C, Ambient ground temperature of 30 °C, Soil thermal resistivity of 1.5 K·m/W, Depth of laying of 0.8 m, and cable screens are bonded at both ends. In case of different laying conditions, appropriate correction (derating) factors from *Annex E* have to be applied to cater for the actual installation conditions.

Three-Core Cables, with Copper Conductors, XLPE Insulated and PVC Sheathed

APPLICATION

Suitable for installations indoors: mostly in power supply stations and outdoors: in cable ducts, underground, and on cable trays for industries, switch-boards and power stations.

APPLICABLE STANDARDS

alfanar medium voltage cables are designed and tested to meet or exceed the requirements of IEC 60502-2 standard. However, **alfanar** can also supply a range of alternative designs to meet customer-specified requirements.

CABLE CONSTRUCTION

Conductor

Plain annealed stranded circular compacted copper conductor (Class 2).

Conductor Screen

Extruded layer of a cross-linkable semi-conducting compound as a stress control layer.

Insulation

Extruded layer of cross-linked polyethylene (XLPE).

Insulation Screen

Extruded layer of a cross-linkable semi-conducting compound firmly bonded to the insulation.

Metallic Screen

Flat plain copper tape helically applied over the insulation screen with suitable overlap.

Filler

Non-hygroscopic polypropylene filler suitable for the cable's operating temperature.

Outer Jacket

Extruded layer of Polyvinyl chloride (PVC).

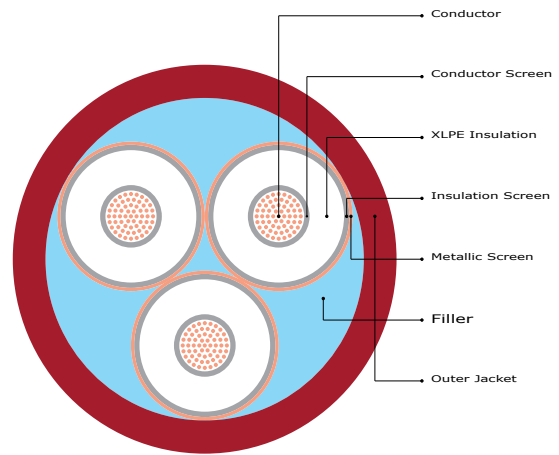

Note: The conductor screen, XLPE insulation and the insulation screen are extruded simultaneously in one process using triple extrusion method (Continuous Vulcanization Line). Triple extrusion method not only assures clean interfaces between the insulation and stress control layers, but also assures a construction free of Partial Discharge with high operational reliability.

TECHNICAL DATA

Rated voltage $U_0 / U (U_m)$	8.7 / 15 (17.5)	kV
Impulse test voltage (peak value)	95	kV
Power frequency test voltage for 5 minutes	30.5	kV
Max. conductor operating temperature at Normal conditions	90	°C
Max. conductor operating temperature at Emergency conditions	130	°C
Max. conductor operating temperature at Short circuit conditions	250	°C
Min. bending radius during installation in terms of cable outer diameter	15 Ø	

The above data is approximate and subject to manufacturing tolerance.

We reserve the right to change the above figures as a result of product development and/or changes in standard.

Constructional Data

Conductor		Insulation			Screen	Armour	Packing			Cable Code
Nominal area of conductor	Approx. conductor diameter	Thickness of insulation layers			Approx. metallic screen tape thickness	N / A	Approx. overall diameter	Approx. overall weight	Standard cutting length $\pm 5\%$	
		C.S	XLPE	I.S						
mm ²	mm	Min.	Nom.	Min.	mm	mm	mm	kg / km	m	
25	5.85	0.3	4.5	0.3	0.076	-	42.5	2037	1000	C316XJ3BB0MRDXXI0MR
35	6.90	0.3	4.5	0.3	0.076	-	44.8	2419	1000	C317XJ3BB0MRDXXI0MR
50	8.10	0.3	4.5	0.3	0.076	-	47.6	2912	1000	C318XJ3BB0MRDXXI0MR
70	9.70	0.3	4.5	0.3	0.076	-	51.3	3662	1000	C319XJ3BB0MRDXXI0MR
95	11.30	0.3	4.5	0.3	0.076	-	54.9	4540	1000	C345XJ3BB0MRDXXI0MR
120	12.60	0.3	4.5	0.3	0.076	-	57.9	5402	500	C346XJ3BB0MRDXXI0MF
150	14.10	0.3	4.5	0.3	0.076	-	61.4	6293	500	C347XJ3BB0MRDXXI0MF
185	15.80	0.3	4.5	0.3	0.076	-	65.2	7568	500	C348XJ3BB0MRDXXI0MF
240	18.10	0.3	4.5	0.3	0.076	-	70.6	9433	500	C349XJ3BB0MRDXXI0MF
300	20.50	0.3	4.5	0.3	0.076	-	76.0	11422	400	C350XJ3BB0MRDXXI0MU
400	23.10	0.3	4.5	0.3	0.076	-	82.2	14176	400	C351XJ3BB0MRDXXI0MU

Electrical Data

Nominal area of conductor	Electrical Characteristics					Continuous Current Ratings		
	Max. Conductor Resistance		Reactance (60 Hz)	Impedance (90 °C, 60 Hz)	Capacitance	Buried direct in the ground	In a buried duct	In air
	DC at 20 °C	AC at 90 °C				Fig. (a)	Fig. (b)	Fig. (c)
mm ²	Ω / km	Ω / km	Ω / km	Ω / km	μF / km	A	A	A
25	0.7270	0.9272	0.161	0.941	0.166	128	106	141
35	0.5240	0.6684	0.153	0.686	0.183	152	127	171
50	0.3870	0.4939	0.142	0.514	0.202	179	151	204
70	0.2680	0.3424	0.134	0.368	0.228	218	185	254
95	0.1930	0.2471	0.128	0.278	0.253	260	222	309
120	0.1530	0.1964	0.124	0.232	0.273	294	253	355
150	0.1240	0.1599	0.120	0.200	0.297	329	284	403
185	0.0991	0.1287	0.115	0.173	0.324	371	322	462
240	0.0754	0.0993	0.111	0.149	0.360	426	374	542
300	0.0601	0.0808	0.107	0.134	0.397	478	422	619
400	0.0470	0.0654	0.104	0.123	0.438	536	477	708

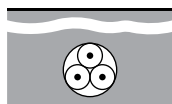

Fig. (a)

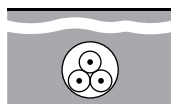

Fig. (b)



Fig. (c)

Laying Conditions: Ambient air temperature of 40 °C, Ambient ground temperature of 30 °C, Soil thermal resistivity of 1.5 K·m/W, Depth of laying of 0.8 m, and cable screens are bonded at both ends. In case of different laying conditions, appropriate correction (derating) factors from *Annex E* have to be applied to cater for the actual installation conditions.

Single-Core Cables, with Copper Conductors, XLPE Insulated, Tape Armoured and PVC Sheathed

APPLICATION

Suitable for installations indoors: mostly in power supply stations and outdoors: in cable ducts, underground, and on cable trays for industries, switch-boards and power stations. Due to the good laying and mechanical characteristics, this cable is suitable when mechanical protection is required or in applications where mechanical damages are expected to occur.

APPLICABLE STANDARDS

alfanar medium voltage cables are designed and tested to meet or exceed the requirements of IEC 60502-2 standard. However, **alfanar** can also supply a range of alternative designs to meet customer-specified requirements.

CABLE CONSTRUCTION

Conductor

Plain annealed stranded circular compacted copper conductor (Class 2).

Conductor Screen

Extruded layer of a cross-linkable semi-conducting compound as a stress control layer.

Insulation

Extruded layer of cross-linked polyethylene (XLPE).

Insulation Screen

Extruded layer of a cross-linkable semi-conducting compound firmly bonded to the insulation.

Metallic Screen

Flat plain copper tape helically applied over the insulation screen with suitable overlap.

Bedding

Extruded layer of Polyvinyl chloride (PVC).

Armouring

Double layer of non-magnetic (aluminum) tapes.

Outer Jacket

Extruded layer of Polyvinyl chloride (PVC).

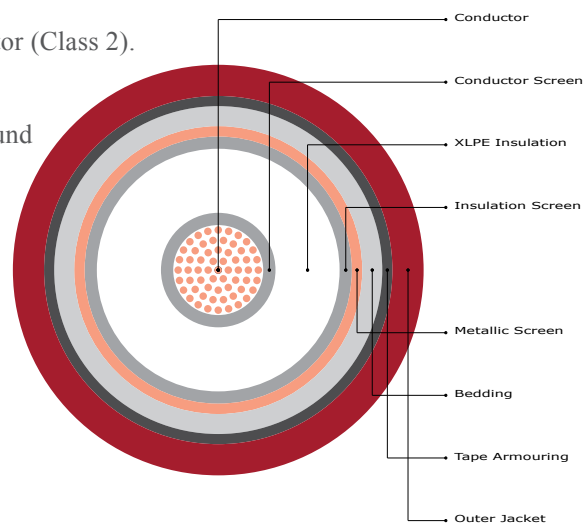

Note: The conductor screen, XLPE insulation and the insulation screen are extruded simultaneously in one process using triple extrusion method (Continuous Vulcanization Line). Triple extrusion method not only assures clean interfaces between the insulation and stress control layers, but also assures a construction free of Partial Discharge with high operational reliability.

TECHNICAL DATA

Rated voltage $U_0 / U (U_m)$	8.7 / 15 (17.5)	kV
Impulse test voltage (peak value)	95	kV
Power frequency test voltage for 5 minutes	30.5	kV
Max. conductor operating temperature at Normal conditions	90	°C
Max. conductor operating temperature at Emergency conditions	130	°C
Max. conductor operating temperature at Short circuit conditions	250	°C
Min. bending radius during installation in terms of cable outer diameter	15 Ø	

The above data is approximate and subject to manufacturing tolerance.

We reserve the right to change the above figures as a result of product development and/or changes in standard.

Constructional Data

Conductor		Insulation			Screen	Armour	Packing			Cable Code
Nominal area of conductor	Approx. conductor diameter	Thickness of insulation layers			Approx. metallic screen tape thickness	Tape thickness	Approx. overall diameter	Approx. overall weight	Standard cutting length $\pm 5\%$	
		C.S	XLPE	I.S						
mm ²	mm	Min.	Nom.	Min.	mm	mm	mm	kg / km	m	
25	5.85	0.3	4.5	0.3	0.076	0.50	25.2	892	1000	C316XJ1BBBMRDXXI0MR
35	6.90	0.3	4.5	0.3	0.076	0.50	26.2	1018	1000	C317XJ1BBBMRDXXI0MR
50	8.10	0.3	4.5	0.3	0.076	0.50	27.6	1192	1000	C318XJ1BBBMRDXXI0MR
70	9.70	0.3	4.5	0.3	0.076	0.50	29.2	1439	1000	C319XJ1BBBMRDXXI0MR
95	11.30	0.3	4.5	0.3	0.076	0.50	31.0	1743	1000	C345XJ1BBBMRDXXI0MR
120	12.60	0.3	4.5	0.3	0.076	0.50	32.3	2024	1000	C346XJ1BBBMRDXXI0MR
150	14.10	0.3	4.5	0.3	0.076	0.50	34.0	2328	1000	C347XJ1BBBMRDXXI0MR
185	15.80	0.3	4.5	0.3	0.076	0.50	35.7	2745	1000	C348XJ1BBBMRDXXI0MR
240	18.10	0.3	4.5	0.3	0.076	0.50	38.2	3360	1000	C349XJ1BBBMRDXXI0MR
300	20.50	0.3	4.5	0.3	0.076	0.50	40.8	4026	1000	C350XJ1BBBMRDXXI0MR
400	23.10	0.3	4.5	0.3	0.076	0.50	43.8	4941	1000	C351XJ1BBBMRDXXI0MR
500	26.50	0.3	4.5	0.3	0.076	0.50	47.6	6176	500	C352XJ1BBBMRDXXI0MF
630	30.05	0.3	4.5	0.3	0.076	0.50	51.4	7542	500	C353XJ1BBBMRDXXI0MF
800	34.00	0.3	4.5	0.3	0.076	0.50	55.9	9474	500	C354XJ1BBBMRDXXI0MF
1000	40.00	0.3	4.5	0.3	0.076	0.50	63.9	11872	500	C755XJ1BBBMRDXXI0MF

Electrical Data

Nominal area of conductor	Electrical Characteristics					Continuous Current Ratings						
	Max. Conductor Resistance		Reactance (60 Hz)	Impedance (90 °C, 60 Hz)	Capacitance	Buried direct in the ground		In single-way ducts		In air		
	DC at 20 °C	AC at 90 °C				Trefoil	Flat spaced	Trefoil	Flat touched	Trefoil	Flat touched	Flat spaced
	mm ²	Ω / km	Ω / km	Ω / km	Ω / km	$\mu\text{F} / \text{km}$	A	A	A	A	A	A
25	0.7270	0.9272	0.187	0.946	0.166	127	132	116	116	144	147	171
35	0.5240	0.6684	0.177	0.691	0.183	151	157	139	139	175	178	207
50	0.3870	0.4938	0.166	0.521	0.202	178	184	164	163	209	214	248
70	0.2680	0.3422	0.156	0.376	0.228	217	224	200	199	261	266	308
95	0.1930	0.2469	0.149	0.288	0.253	258	265	239	237	317	323	373
120	0.1530	0.1961	0.144	0.243	0.273	291	298	271	267	364	370	426
150	0.1240	0.1594	0.140	0.212	0.297	326	331	303	298	414	420	482
185	0.0991	0.1281	0.134	0.185	0.324	366	369	341	334	474	480	548
240	0.0754	0.0985	0.128	0.162	0.360	421	419	393	381	558	562	639
300	0.0601	0.0798	0.124	0.147	0.397	473	464	441	425	639	640	723
400	0.0470	0.0640	0.120	0.136	0.438	530	513	496	473	733	730	817
500	0.0366	0.0519	0.116	0.127	0.491	592	564	556	524	841	830	924
630	0.0283	0.0427	0.112	0.120	0.546	652	597	610	562	949	921	1006
800	0.0221	0.0362	0.109	0.115	0.610	705	622	657	591	1054	1005	1080
1000	0.0176	0.0246	0.105	0.108	0.725	831	662	743	643	1296	1188	1201

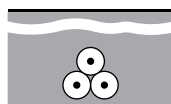

Fig. (a)

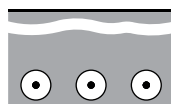

Fig. (b)

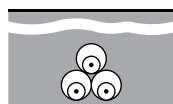

Fig. (c)

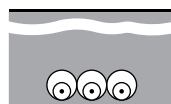

Fig. (d)

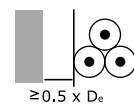

Fig. (e)

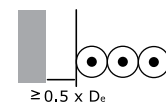

Fig. (f)

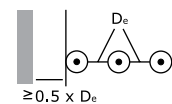

Fig. (g)

Laying Conditions: Ambient air temperature of 40 °C, Ambient ground temperature of 30 °C, Soil thermal resistivity of 1.5 K·m/W, Depth of laying of 0.8 m, and cable screens are bonded at both ends. In case of different laying conditions, appropriate correction (derating) factors from *Annex E* have to be applied to cater for the actual installation conditions.

Three-Core Cables, with Copper Conductors, XLPE Insulated, Tape Armoured and PVC Sheathed

APPLICATION

Suitable for installations indoors: mostly in power supply stations and outdoors: in cable ducts, underground, and on cable trays for industries, switch-boards and power stations. Due to the good laying and mechanical characteristics, this cable is suitable when mechanical protection is required or in applications where mechanical damages are expected to occur.

APPLICABLE STANDARDS

alfanar medium voltage cables are designed and tested to meet or exceed the requirements of IEC 60502-2 standard. However, **alfanar** can also supply a range of alternative designs to meet customer-specified requirements.

CABLE CONSTRUCTION

Conductor

Plain annealed stranded circular compacted copper conductor (Class 2).

Conductor Screen

Extruded layer of a cross-linkable semi-conducting compound as a stress control layer.

Insulation

Extruded layer of cross-linked polyethylene (XLPE).

Insulation Screen

Extruded layer of a cross-linkable semi-conducting compound firmly bonded to the insulation.

Metallic Screen

Flat plain copper tape helically applied over the insulation screen with suitable overlap.

Filler

Non-hygroscopic polypropylene filler suitable for the cable's operating temperature.

Bedding

Extruded layer of Polyvinyl chloride (PVC).

Armouring

Double layer of galvanized steel tapes.

Outer Jacket

Extruded layer of Polyvinyl chloride (PVC).

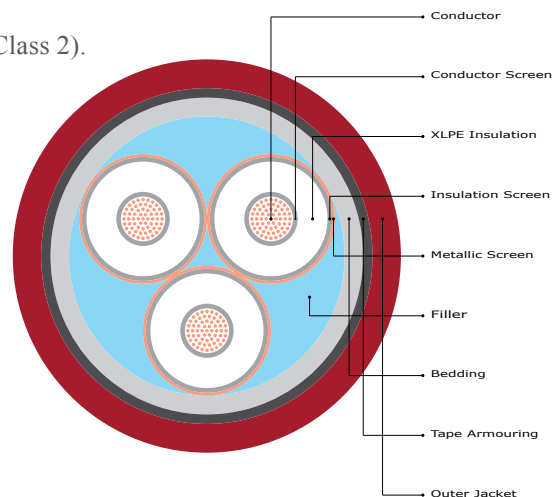

Note: The conductor screen, XLPE insulation and the insulation screen are extruded simultaneously in one process using triple extrusion method (Continuous Vulcanization Line). Triple extrusion method not only assures clean interfaces between the insulation and stress control layers, but also assures a construction free of Partial Discharge with high operational reliability.

TECHNICAL DATA

Rated voltage $U_0 / U (U_m)$	8.7 / 15 (17.5)	kV
Impulse test voltage (peak value)	95	kV
Power frequency test voltage for 5 minutes	30.5	kV
Max. conductor operating temperature at Normal conditions	90	°C
Max. conductor operating temperature at Emergency conditions	130	°C
Max. conductor operating temperature at Short circuit conditions	250	°C
Min. bending radius during installation in terms of cable outer diameter	12 Ø	

Constructional Data

Conductor		Insulation			Screen	Armour	Packing			Cable Code
Nominal area of conductor	Approx. conductor diameter	Thickness of insulation layers			Approx. metallic screen tape thickness	Tape thickness	Approx. overall diameter	Approx. overall weight	Standard cutting length $\pm 5\%$	
		C.S.	XLPE	I.S.						
mm ²	mm	Min.	Nom.	Min.	mm	mm	mm	kg / km	m	
25	5.85	0.3	4.5	0.3	0.076	0.50	47.5	3074	1000	C316XJ3BBGMRDXXI0MR
35	6.90	0.3	4.5	0.3	0.076	0.50	49.8	3507	1000	C317XJ3BBGMRDXXI0MR
50	8.10	0.3	4.5	0.3	0.076	0.50	52.8	4094	1000	C318XJ3BBGMRDXXI0MR
70	9.70	0.3	4.5	0.3	0.076	0.50	56.5	4932	1000	C319XJ3BBGMRDXXI0MR
95	11.30	0.3	4.5	0.3	0.076	0.50	60.5	5958	500	C345XJ3BBGMRDXXI0MF
120	12.60	0.3	4.5	0.3	0.076	0.50	63.7	6927	500	C346XJ3BBGMRDXXI0MF
150	14.10	0.3	4.5	0.3	0.076	0.50	67.2	7907	500	C347XJ3BBGMRDXXI0MF
185	15.80	0.3	4.5	0.3	0.076	0.50	71.2	9315	500	C348XJ3BBGMRDXXI0MF
240	18.10	0.3	4.5	0.3	0.076	0.50	76.8	11358	500	C349XJ3BBGMRDXXI0MF
300	20.50	0.3	4.5	0.3	0.076	0.50	83.8	14346	400	C350XJ3BBGMRDXXI0MU
400	23.10	0.3	4.5	0.3	0.076	0.80	90.0	17327	350	C351XJ3BBGMRDXXI0MV

Electrical Data

Nominal area of conductor	Electrical Characteristics					Continuous Current Ratings		
	Max. Conductor Resistance		Reactance (60 Hz)	Impedance (90 °C, 60 Hz)	Capacitance	Buried direct in the ground	In a buried duct	In air
	DC at 20 °C	AC at 90 °C				Fig. (a)	Fig. (b)	Fig. (c)
mm ²	Ω / km	Ω / km	Ω / km	Ω / km	$\mu\text{F} / \text{km}$	A	A	A
25	0.7270	0.9272	0.161	0.941	0.166	122	104	132
35	0.5240	0.6684	0.153	0.686	0.183	146	125	160
50	0.3870	0.4939	0.142	0.514	0.202	171	147	190
70	0.2680	0.3424	0.134	0.368	0.228	208	180	235
95	0.1930	0.2471	0.128	0.278	0.253	248	216	285
120	0.1530	0.1964	0.124	0.232	0.273	280	245	325
150	0.1240	0.1599	0.120	0.200	0.297	313	276	369
185	0.0991	0.1287	0.115	0.173	0.324	352	312	419
240	0.0754	0.0993	0.111	0.149	0.360	404	360	489
300	0.0601	0.0808	0.107	0.134	0.397	451	405	555
400	0.0470	0.0654	0.104	0.123	0.438	506	458	633

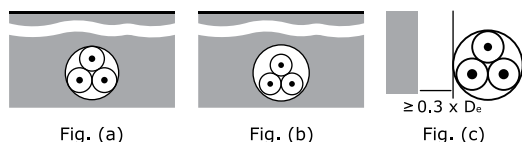

Laying Conditions: Ambient air temperature of 40 °C, Ambient ground temperature of 30 °C, Soil thermal resistivity of 1.5 K·m/W, Depth of laying of 0.8 m. and cable screens are bonded at both ends. In case of different laying conditions, appropriate correction (derating) factors from *Annex E* have to be applied to cater for the actual installation conditions.

Single-Core Cables, with Copper Conductors, XLPE Insulated, Wire Armoured and PVC Sheathed

APPLICATION

Suitable for installations indoors: mostly in power supply stations and outdoors: in cable ducts, underground, and on cable trays for industries, switch-boards and power stations. Due to the good laying and mechanical characteristics, this cable is suitable when mechanical protection is required or in applications where mechanical damages are expected to occur.

APPLICABLE STANDARDS

alfanar medium voltage cables are designed and tested to meet or exceed the requirements of IEC 60502-2 standard and/or BS 6622 standard with rated voltage 8.7 / 15 (17.5) kV. However, **alfanar** can also supply a range of alternative designs to meet customer-specified requirements.

CABLE CONSTRUCTION

Conductor

Stranded circular compacted aluminum conductor (Class 2).

Conductor Screen

Extruded layer of a cross-linkable semi-conducting compound as a stress control layer.

Insulation

Extruded layer of cross-linked polyethylene (XLPE).

Insulation Screen

Extruded layer of a cross-linkable semi-conducting compound firmly bonded to the insulation.

Metallic Screen

Flat plain copper tape helically applied over the insulation screen with suitable overlap.

Bedding

Extruded layer of Polyvinyl chloride (PVC).

Armouring

Single layer of round non-magnetic (aluminum) wires.

Outer Jacket

Extruded layer of Polyvinyl chloride (PVC).

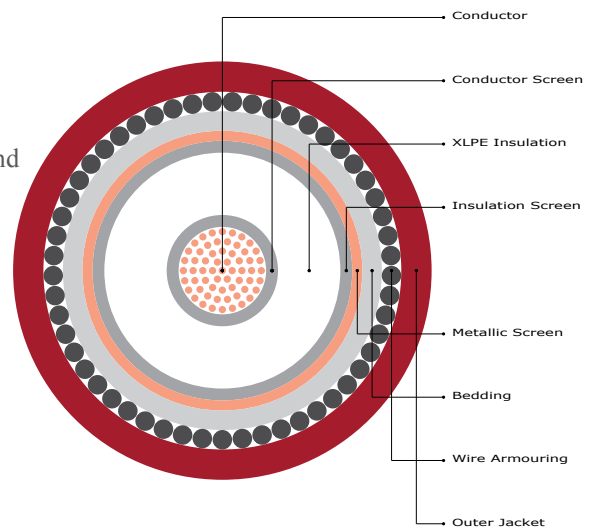

Note: The conductor screen, XLPE insulation and the insulation screen are extruded simultaneously in one process using triple extrusion method (Continuous Vulcanization Line). Triple extrusion method not only assures clean interfaces between the insulation and stress control layers, but also assures a construction free of Partial Discharge with high operational reliability.

TECHNICAL DATA

Rated voltage $U_0 / U (U_m)$	8.7 / 15 (17.5)	kV
Impulse test voltage (peak value)	95	kV
Power frequency test voltage for 5 minutes	30.5	kV
Max. conductor operating temperature at Normal conditions	90	°C
Max. conductor operating temperature at Emergency conditions	130	°C
Max. conductor operating temperature at Short circuit conditions	250	°C
Min. bending radius during installation in terms of cable outer diameter	15 Ø	

The above data is approximate and subject to manufacturing tolerance.

We reserve the right to change the above figures as a result of product development and/or changes in standard.

Constructional Data

Conductor		Insulation			Screen	Armour	Packing			Cable Code
Nominal area of conductor	Approx. conductor diameter	Thickness of insulation layers			Approx. metallic screen tape thickness	Wire diameter	Approx. overall diameter	Approx. overall weight	Standard cutting length $\pm 5\%$	
		C.S	XLPE	I.S						
mm ²	mm	Min.	Nom.	Min.	mm	mm	mm	kg / km	m	
25	5.85	0.3	4.5	0.3	0.076	1.60	26.9	1010	1000	C316XJ1BBAMRDXXI0MR
35	6.90	0.3	4.5	0.3	0.076	1.60	28.1	1156	1000	C317XJ1BBAMRDXXI0MR
50	8.10	0.3	4.5	0.3	0.076	1.60	29.3	1321	1000	C318XJ1BBAMRDXXI0MR
70	9.70	0.3	4.5	0.3	0.076	1.60	31.1	1592	1000	C319XJ1BBAMRDXXI0MR
95	11.30	0.3	4.5	0.3	0.076	2.00	33.5	1970	1000	C345XJ1BBAMRDXXI0MR
120	12.60	0.3	4.5	0.3	0.076	2.00	35.0	2279	1000	C346XJ1BBAMRDXXI0MR
150	14.10	0.3	4.5	0.3	0.076	2.00	36.5	2577	1000	C347XJ1BBAMRDXXI0MR
185	15.80	0.3	4.5	0.3	0.076	2.00	38.4	3032	1000	C348XJ1BBAMRDXXI0MR
240	18.10	0.3	4.5	0.3	0.076	2.00	40.9	3662	1000	C349XJ1BBAMRDXXI0MR
300	20.50	0.3	4.5	0.3	0.076	2.00	43.3	4325	1000	C350XJ1BBAMRDXXI0MR
400	23.10	0.3	4.5	0.3	0.076	2.50	47.5	5435	1000	C351XJ1BBAMRDXXI0MR
500	26.50	0.3	4.5	0.3	0.076	2.50	51.3	6712	1000	C352XJ1BBAMRDXXI0MF
630	30.05	0.3	4.5	0.3	0.076	2.50	55.1	8118	1000	C353XJ1BBAMRDXXI0MF
800	34.00	0.3	4.5	0.3	0.076	2.50	59.6	10100	500	C354XJ1BBAMRDXXI0MF
1000	40.00	0.3	4.5	0.3	0.076	2.50	67.6	12580	500	C755XJ1BBAMRDXXI0MF

Electrical Data

Nominal area of conductor	Electrical Characteristics					Continuous Current Ratings						
	Max. Conductor Resistance		Reactance (60 Hz)	Impedance (90 °C, 60 Hz)	Capacitance	Buried direct in the ground		In single-way ducts		In air		
	DC at 20 °C	AC at 90 °C				Trefoil	Flat spaced	Trefoil	Flat touched	Trefoil	Flat touched	Flat spaced
	mm ²	Ω / km	Ω / km	Ω / km	Ω / km	$\mu\text{F} / \text{km}$	A	A	A	A	A	A
25	0.7270	0.9272	0.191	0.947	0.166	127	131	118	116	148	150	173
35	0.5240	0.6684	0.182	0.693	0.183	152	155	140	138	179	182	208
50	0.3870	0.4938	0.170	0.522	0.202	178	180	164	161	214	217	247
70	0.2680	0.3422	0.161	0.378	0.228	216	214	198	193	265	267	303
95	0.1930	0.2468	0.155	0.291	0.253	256	249	234	225	320	320	361
120	0.1530	0.1960	0.150	0.247	0.273	286	270	260	246	366	361	402
150	0.1240	0.1593	0.145	0.215	0.297	317	292	286	268	413	403	446
185	0.0991	0.1280	0.139	0.189	0.324	353	317	316	293	469	453	495
240	0.0754	0.0984	0.134	0.166	0.360	399	346	353	321	542	514	555
300	0.0601	0.0796	0.129	0.151	0.397	439	369	385	345	611	571	608
400	0.0470	0.0637	0.126	0.141	0.438	473	388	410	362	679	618	661
500	0.0366	0.0515	0.121	0.132	0.491	513	411	442	386	757	676	722
630	0.0283	0.0423	0.117	0.125	0.546	551	434	472	409	835	733	782
800	0.0221	0.0356	0.114	0.119	0.610	583	456	499	429	907	784	841
1000	0.0176	0.0245	0.109	0.112	0.725	626	493	540	465	1022	876	947

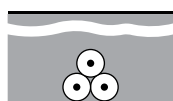

Fig. (a)

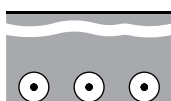

Fig. (b)

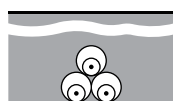

Fig. (c)

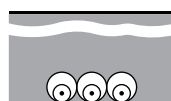

Fig. (d)

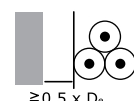

Fig. (e)

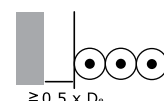

Fig. (f)

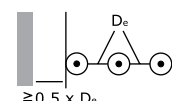

Fig. (g)

Laying Conditions: Ambient air temperature of 40 °C, Ambient ground temperature of 30 °C, Soil thermal resistivity of 1.5 K·m/W, Depth of laying of 0.8 m, and cable screens are bonded at both ends. In case of different laying conditions, appropriate correction (derating) factors from *Annex E* have to be applied to cater for the actual installation conditions.

Three-Core Cables, with Copper Conductors, XLPE Insulated, Wire Armoured and PVC Sheathed

APPLICATION

Suitable for installations indoors: mostly in power supply stations and outdoors: in cable ducts, underground, and on cable trays for industries, switch-boards and power stations. Due to the good laying and mechanical characteristics, this cable is suitable when mechanical protection is required or in applications where mechanical damages are expected to occur.

APPLICABLE STANDARDS

alfanar medium voltage cables are designed and tested to meet or exceed the requirements of IEC 60502-2 standard and/or BS 6622 standard with rated voltage 8.7 / 15 (17.5) kV. However, **alfanar** can also supply a range of alternative designs to meet customer-specified requirements.

CABLE CONSTRUCTION

Conductor

Plain annealed stranded circular compacted copper conductor (Class 2).

Conductor Screen

Extruded layer of a cross-linkable semi-conducting compound as a stress control layer.

Insulation

Extruded layer of cross-linked polyethylene (XLPE).

Insulation Screen

Extruded layer of a cross-linkable semi-conducting compound firmly bonded to the insulation.

Metallic Screen

Flat plain copper tape helically applied over the insulation screen with suitable overlap.

Filler

Non-hygroscopic polypropylene filler suitable for the cable's operating temperature.

Bedding

Extruded layer of Polyvinyl chloride (PVC).

Armouring

Single layer of round galvanized steel wires.

Outer Jacket

Extruded layer of Polyvinyl chloride (PVC).

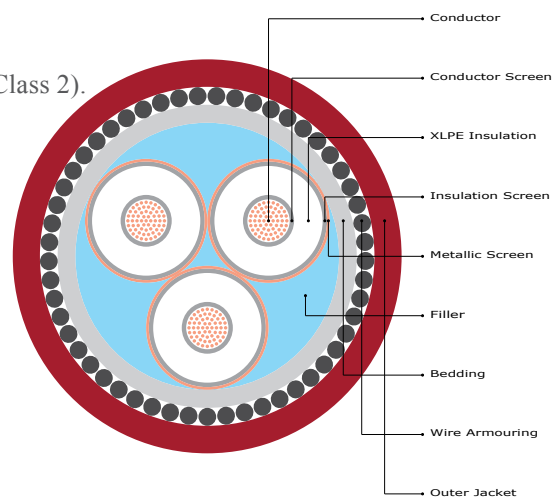

Note: The conductor screen, XLPE insulation and the insulation screen are extruded simultaneously in one process using triple extrusion method (Continuous Vulcanization Line). Triple extrusion method not only assures clean interfaces between the insulation and stress control layers, but also assures a construction free of Partial Discharge with high operational reliability.

TECHNICAL DATA

Rated voltage $U_0 / U (U_m)$	8.7 / 15 (17.5)	kV
Impulse test voltage (peak value)	95	kV
Power frequency test voltage for 5 minutes	30.5	kV
Max. conductor operating temperature at Normal conditions	90	°C
Max. conductor operating temperature at Emergency conditions	130	°C
Max. conductor operating temperature at Short circuit conditions	250	°C
Min. bending radius during installation in terms of cable outer diameter	12 \emptyset	

Constructional Data

Conductor		Insulation			Screen	Armour	Packing			Cable Code
Nominal area of conductor	Approx. conductor diameter	Thickness of insulation layers			Approx. metallic screen tape thickness	Wire diameter	Approx. overall diameter	Approx. overall weight	Standard cutting length $\pm 5\%$	
		C.S.	XLPE	I.S.						
mm ²	mm	Min.	Nom.	Min.	mm	mm	mm	kg / km	m	
25	5.85	0.3	4.5	0.3	0.076	2.50	50.7	4543	1000	C316XJ3BBWMDXXI0MR
35	6.90	0.3	4.5	0.3	0.076	2.50	53.0	5033	1000	C317XJ3BBWMDXXI0MR
50	8.10	0.3	4.5	0.3	0.076	2.50	56.0	5704	1000	C318XJ3BBWMDXXI0MR
70	9.70	0.3	4.5	0.3	0.076	2.50	59.7	6658	1000	C319XJ3BBWMDXXI0MR
95	11.30	0.3	4.5	0.3	0.076	2.50	63.7	7800	500	C345XJ3BBWMDXXI0MF
120	12.60	0.3	4.5	0.3	0.076	2.50	66.9	8891	500	C346XJ3BBWMDXXI0MF
150	14.10	0.3	4.5	0.3	0.076	3.15	72.3	10916	500	C347XJ3BBWMDXXI0MF
185	15.80	0.3	4.5	0.3	0.076	3.15	76.3	12474	500	C348XJ3BBWMDXXI0MF
240	18.10	0.3	4.5	0.3	0.076	3.15	81.9	14785	400	C349XJ3BBWMDXXI0MU
300	20.50	0.3	4.5	0.3	0.076	3.15	87.7	17264	400	C350XJ3BBWMDXXI0MU
400	23.10	0.3	4.5	0.3	0.076	3.15	93.9	20445	300	C351XJ3BBWMDXXI0MT

Electrical Data

Nominal area of conductor	Electrical Characteristics					Continuous Current Ratings		
	Max. Conductor Resistance		Reactance (60 Hz)	Impedance (90 °C, 60 Hz)	Capacitance	Buried direct in the ground	In a buried duct	In air
	DC at 20 °C	AC at 90 °C				Fig. (a)	Fig. (b)	Fig. (c)
mm ²	Ω / km	Ω / km	Ω / km	Ω / km	$\mu\text{F} / \text{km}$	A	A	A
25	0.7270	0.9272	0.161	0.941	0.166	123	106	135
35	0.5240	0.6684	0.153	0.686	0.183	146	126	163
50	0.3870	0.4939	0.142	0.514	0.202	171	149	193
70	0.2680	0.3424	0.134	0.368	0.228	208	182	238
95	0.1930	0.2471	0.128	0.278	0.253	247	217	287
120	0.1530	0.1964	0.124	0.232	0.273	278	245	327
150	0.1240	0.1599	0.120	0.200	0.297	309	274	369
185	0.0991	0.1287	0.115	0.173	0.324	345	307	417
240	0.0754	0.0993	0.111	0.149	0.360	391	351	482
300	0.0601	0.0808	0.107	0.134	0.397	431	389	541
400	0.0470	0.0654	0.104	0.123	0.438	475	431	606

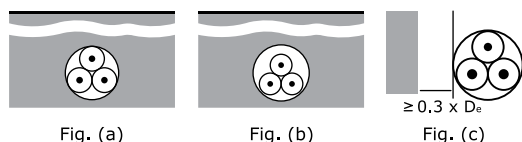

Fig. (a)

Fig. (b)

Fig. (c)

Laying Conditions: Ambient air temperature of 40 °C, Ambient ground temperature of 30 °C, Soil thermal resistivity of 1.5 K·m/W, Depth of laying of 0.8 m. and cable screens are bonded at both ends. In case of different laying conditions, appropriate correction (derating) factors from *Annex E* have to be applied to cater for the actual installation conditions.

Single-Core Cables, with Aluminum Conductors, XLPE Insulated and PVC Sheathed

APPLICATION

Suitable for installations indoors: mostly in power supply stations and outdoors: in cable ducts, underground, and on cable trays for industries, switch-boards and power stations.

APPLICABLE STANDARDS

alfanar medium voltage cables are designed and tested to meet or exceed the requirements of IEC 60502-2 standard. However, **alfanar** can also supply a range of alternative designs to meet customer-specified requirements.

CABLE CONSTRUCTION

Conductor

Stranded circular compacted aluminum conductor (Class 2).

Conductor Screen

Extruded layer of a cross-linkable semi-conducting compound as a stress control layer.

Insulation

Extruded layer of cross-linked polyethylene (XLPE).

Insulation Screen

Extruded layer of a cross-linkable semi-conducting compound firmly bonded to the insulation.

Metallic Screen

Flat plain copper tape helically applied over the insulation screen with suitable overlap.

Outer Jacket

Extruded layer of Polyvinyl chloride (PVC).

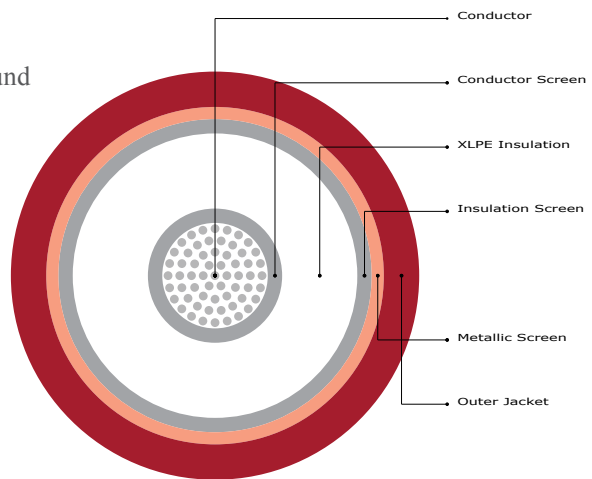

Note: The conductor screen, XLPE insulation and the insulation screen are extruded simultaneously in one process using triple extrusion method (Continuous Vulcanization Line). Triple extrusion method not only assures clean interfaces between the insulation and stress control layers, but also assures a construction free of Partial Discharge with high operational reliability.

TECHNICAL DATA

Rated voltage $U_0 / U (U_m)$	8.7 / 15 (17.5)	kV
Impulse test voltage (peak value)	95	kV
Power frequency test voltage for 5 minutes	30.5	kV
Max. conductor operating temperature at Normal conditions	90	°C
Max. conductor operating temperature at Emergency conditions	130	°C
Max. conductor operating temperature at Short circuit conditions	250	°C
Min. bending radius during installation in terms of cable outer diameter	20 Ø	

The above data is approximate and subject to manufacturing tolerance.

We reserve the right to change the above figures as a result of product development and/or changes in standard.

Constructional Data

Conductor		Insulation			Screen	Armour	Packing			Cable Code
Nominal area of conductor	Approx. conductor diameter	Thickness of insulation layers			Approx. metallic screen tape thickness	N / A	Approx. overall diameter	Approx. overall weight	Standard cutting length $\pm 5\%$	
		C.S	XLPE	I.S						
mm ²	mm	Min.	Nom.	Min.	mm	mm	mm	kg / km	m	
25	5.85	0.3	4.5	0.3	0.076	-	20.4	452	1000	A316XJ1BB0MRDXXI0MR
35	6.90	0.3	4.5	0.3	0.076	-	21.6	515	1000	A317XJ1BB0MRDXXI0MR
50	8.10	0.3	4.5	0.3	0.076	-	22.8	582	1000	A318XJ1BB0MRDXXI0MR
70	9.70	0.3	4.5	0.3	0.076	-	24.6	695	1000	A319XJ1BB0MRDXXI0MR
95	11.30	0.3	4.5	0.3	0.076	-	26.2	807	1000	A345XJ1BB0MRDXXI0MR
120	12.60	0.3	4.5	0.3	0.076	-	27.7	930	1000	A346XJ1BB0MRDXXI0MR
150	14.10	0.3	4.5	0.3	0.076	-	29.2	1044	1000	A347XJ1BB0MRDXXI0MR
185	15.80	0.3	4.5	0.3	0.076	-	31.1	1210	1000	A348XJ1BB0MRDXXI0MR
240	18.10	0.3	4.5	0.3	0.076	-	33.6	1447	1000	A349XJ1BB0MRDXXI0MR
300	20.50	0.3	4.5	0.3	0.076	-	36.0	1682	1000	A350XJ1BB0MRDXXI0MR
400	23.10	0.3	4.5	0.3	0.076	-	38.8	2008	1000	A351XJ1BB0MRDXXI0MR
500	26.50	0.3	4.5	0.3	0.076	-	42.4	2433	1000	A352XJ1BB0MRDXXI0MR
630	30.05	0.3	4.5	0.3	0.076	-	46.2	2942	1000	A353XJ1BB0MRDXXI0MR
800	34.00	0.3	4.5	0.3	0.076	-	50.7	3648	500	A354XJ1BB0MRDXXI0MF
1000	40.00	0.3	4.5	0.3	0.076	-	58.3	4526	500	A755XJ1BB0MRDXXI0MF

Electrical Data

Nominal area of conductor	Electrical Characteristics					Continuous Current Ratings						
	Max. Conductor Resistance		Reactance (60 Hz)	Impedance (90 °C, 60 Hz)	Capacitance	Buried direct in the ground		In single-way ducts		In air		
	DC at 20 °C	AC at 90 °C				Trefoil	Flat spaced	Trefoil	Flat touched	Trefoil	Flat touched	Flat spaced
	mm ²	Ω / km	Ω / km	Ω / km	Ω / km	$\mu\text{F} / \text{km}$	A	A	A	A	A	A
25	1.2000	1.5386	0.171	1.548	0.166	98	102	89	89	108	111	132
35	0.8680	1.1130	0.163	1.125	0.183	117	122	106	106	132	135	161
50	0.6410	0.8221	0.151	0.836	0.202	138	144	126	125	158	162	194
70	0.4430	0.5683	0.143	0.586	0.228	168	176	154	154	198	203	242
95	0.3200	0.4108	0.137	0.433	0.253	201	210	184	184	242	248	295
120	0.2530	0.3251	0.133	0.351	0.273	228	237	210	209	279	286	340
150	0.2060	0.2650	0.128	0.294	0.297	254	266	236	235	318	326	387
185	0.1640	0.2115	0.123	0.245	0.324	287	300	268	267	367	376	446
240	0.1250	0.1619	0.119	0.201	0.360	333	346	311	309	435	446	527
300	0.1000	0.1304	0.115	0.174	0.397	375	389	352	349	503	514	606
400	0.0778	0.1027	0.111	0.151	0.438	427	441	403	398	586	598	703
500	0.0605	0.0815	0.107	0.135	0.491	485	499	461	453	685	697	818
630	0.0469	0.0653	0.104	0.123	0.546	547	560	525	511	793	804	941
800	0.0367	0.0536	0.102	0.115	0.610	610	620	590	570	908	916	1070
1000	0.0291	0.0388	0.098	0.106	0.725	728	703	692	657	1131	1127	1265

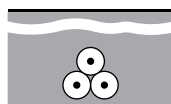

Fig. (a)

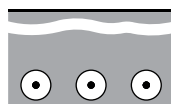

Fig. (b)

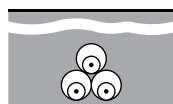

Fig. (c)

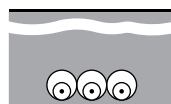

Fig. (d)

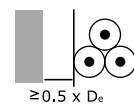

Fig. (e)

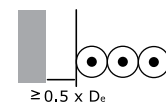

Fig. (f)

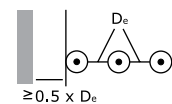

Fig. (g)

Laying Conditions: Ambient air temperature of 40 °C, Ambient ground temperature of 30 °C, Soil thermal resistivity of 1.5 K·m/W, Depth of laying of 0.8 m, and cable screens are bonded at both ends. In case of different laying conditions, appropriate correction (derating) factors from *Annex E* have to be applied to cater for the actual installation conditions.

Three-Core Cables, with Aluminum Conductors, XLPE Insulated and PVC Sheathed

APPLICATION

Suitable for installations indoors: mostly in power supply stations and outdoors: in cable ducts, underground, and on cable trays for industries, switch-boards and power stations.

APPLICABLE STANDARDS

alfanar medium voltage cables are designed and tested to meet or exceed the requirements of IEC 60502-2 standard. However, **alfanar** can also supply a range of alternative designs to meet customer-specified requirements.

CABLE CONSTRUCTION

Conductor

Stranded circular compacted aluminum conductor (Class 2).

Conductor Screen

Extruded layer of a cross-linkable semi-conducting compound as a stress control layer.

Insulation

Extruded layer of cross-linked polyethylene (XLPE).

Insulation Screen

Extruded layer of a cross-linkable semi-conducting compound firmly bonded to the insulation.

Metallic Screen

Flat plain copper tape helically applied over the insulation screen with suitable overlap.

Filler

Non-hygroscopic polypropylene filler suitable for the cable's operating temperature.

Outer Jacket

Extruded layer of Polyvinyl chloride (PVC).

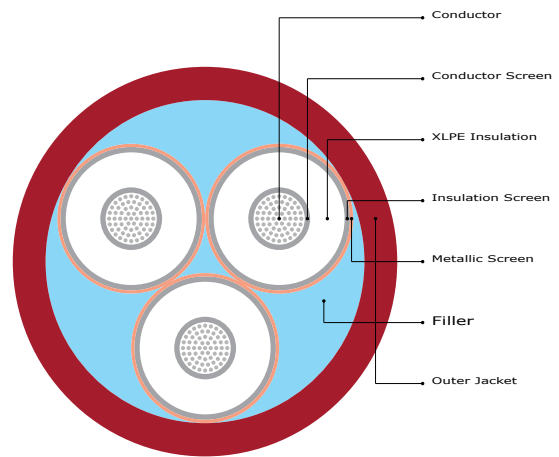

Note: The conductor screen, XLPE insulation and the insulation screen are extruded simultaneously in one process using triple extrusion method (Continuous Vulcanization Line). Triple extrusion method not only assures clean interfaces between the insulation and stress control layers, but also assures a construction free of Partial Discharge with high operational reliability.

TECHNICAL DATA

Rated voltage $U_0 / U (U_m)$	8.7 / 15 (17.5)	kV
Impulse test voltage (peak value)	95	kV
Power frequency test voltage for 5 minutes	30.5	kV
Max. conductor operating temperature at Normal conditions	90	°C
Max. conductor operating temperature at Emergency conditions	130	°C
Max. conductor operating temperature at Short circuit conditions	250	°C
Min. bending radius during installation in terms of cable outer diameter	15 Ø	

The above data is approximate and subject to manufacturing tolerance.

We reserve the right to change the above figures as a result of product development and/or changes in standard.

Constructional Data

Conductor		Insulation			Screen	Armour	Packing			Cable Code
Nominal area of conductor	Approx. conductor diameter	Thickness of insulation layers			Approx. metallic screen tape thickness	N / A	Approx. overall diameter	Approx. overall weight	Standard cutting length $\pm 5\%$	
		C.S	XLPE	I.S						
mm ²	mm	Min.	Nom.	Min.	mm	mm	mm	kg / km	m	
25	5.85	0.3	4.5	0.3	0.076	-	42.5	1575	1000	A316XJ3BB0MRDXXI0MR
35	6.90	0.3	4.5	0.3	0.076	-	44.8	1777	1000	A317XJ3BB0MRDXXI0MR
50	8.10	0.3	4.5	0.3	0.076	-	47.6	2035	1000	A318XJ3BB0MRDXXI0MR
70	9.70	0.3	4.5	0.3	0.076	-	51.3	2408	1000	A319XJ3BB0MRDXXI0MR
95	11.30	0.3	4.5	0.3	0.076	-	54.9	2815	1000	A345XJ3BB0MRDXXI0MR
120	12.60	0.3	4.5	0.3	0.076	-	57.9	3209	500	A346XJ3BB0MRDXXI0MF
150	14.10	0.3	4.5	0.3	0.076	-	61.4	3635	500	A347XJ3BB0MRDXXI0MF
185	15.80	0.3	4.5	0.3	0.076	-	65.2	4175	500	A348XJ3BB0MRDXXI0MF
240	18.10	0.3	4.5	0.3	0.076	-	70.6	5002	500	A349XJ3BB0MRDXXI0MF
300	20.50	0.3	4.5	0.3	0.076	-	76.0	5842	400	A350XJ3BB0MRDXXI0MU
400	23.10	0.3	4.5	0.3	0.076	-	82.2	7006	400	A351XJ3BB0MRDXXI0MU

Electrical Data

Nominal area of conductor	Electrical Characteristics					Continuous Current Ratings		
	Max. Conductor Resistance		Reactance (60 Hz)	Impedance (90 °C, 60 Hz)	Capacitance	Buried direct in the ground	In a buried duct	In air
	DC at 20 °C	AC at 90 °C				Fig. (a)	Fig. (b)	Fig. (c)
mm ²	Ω / km	Ω / km	Ω / km	Ω / km	$\mu\text{F} / \text{km}$	A	A	A
25	1.2000	1.5386	0.161	1.547	0.166	99	82	109
35	0.8680	1.1130	0.153	1.123	0.183	118	99	132
50	0.6410	0.8221	0.142	0.834	0.202	139	117	158
70	0.4430	0.5684	0.134	0.584	0.228	169	144	197
95	0.3200	0.4109	0.128	0.430	0.253	202	172	240
120	0.2530	0.3252	0.124	0.348	0.273	229	197	276
150	0.2060	0.2652	0.120	0.291	0.297	256	221	313
185	0.1640	0.2117	0.115	0.241	0.324	289	252	361
240	0.1250	0.1622	0.111	0.197	0.360	335	293	425
300	0.1000	0.1308	0.107	0.169	0.397	377	333	488
400	0.0778	0.1032	0.104	0.146	0.438	429	382	566

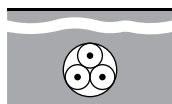

Fig. (a)

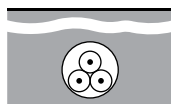

Fig. (b)



Fig. (c)

Laying Conditions: Ambient air temperature of 40 °C, Ambient ground temperature of 30 °C, Soil thermal resistivity of 1.5 K·m/W, Depth of laying of 0.8 m, and cable screens are bonded at both ends. In case of different laying conditions, appropriate correction (derating) factors from *Annex E* have to be applied to cater for the actual installation conditions.

Single-Core Cables, with Aluminum Conductors, XLPE Insulated, Tape Armoured and PVC Sheathed

APPLICATION

Suitable for installations indoors: mostly in power supply stations and outdoors: in cable ducts, underground, and on cable trays for industries, switch-boards and power stations. Due to the good laying and mechanical characteristics, this cable is suitable when mechanical protection is required or in applications where mechanical damages are expected to occur.

APPLICABLE STANDARDS

alfanar medium voltage cables are designed and tested to meet or exceed the requirements of IEC 60502-2 standard. However, **alfanar** can also supply a range of alternative designs to meet customer-specified requirements.

CABLE CONSTRUCTION

Conductor

Stranded circular compacted aluminum conductor (Class 2).

Conductor Screen

Extruded layer of a cross-linkable semi-conducting compound as a stress control layer.

Insulation

Extruded layer of cross-linked polyethylene (XLPE).

Insulation Screen

Extruded layer of a cross-linkable semi-conducting compound firmly bonded to the insulation.

Metallic Screen

Flat plain copper tape helically applied over the insulation screen with suitable overlap.

Bedding

Extruded layer of Polyvinyl chloride (PVC).

Armouring

Double layer of non-magnetic (aluminum) tapes.

Outer Jacket

Extruded layer of Polyvinyl chloride (PVC).

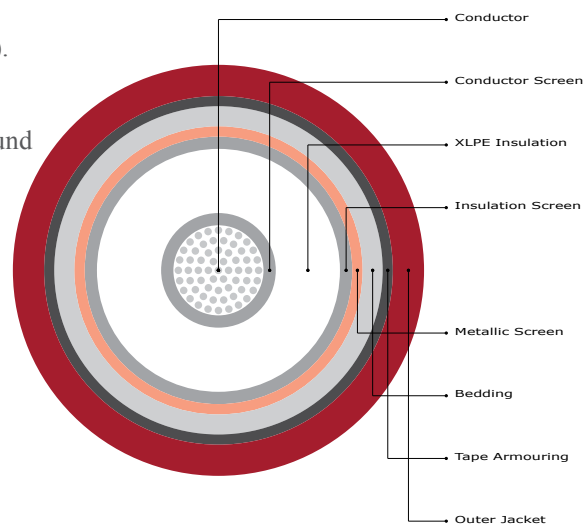

Note: The conductor screen, XLPE insulation and the insulation screen are extruded simultaneously in one process using triple extrusion method (Continuous Vulcanization Line). Triple extrusion method not only assures clean interfaces between the insulation and stress control layers, but also assures a construction free of Partial Discharge with high operational reliability.

TECHNICAL DATA

Rated voltage $U_0 / U (U_m)$	8.7 / 15 (17.5)	kV
Impulse test voltage (peak value)	95	kV
Power frequency test voltage for 5 minutes	30.5	kV
Max. conductor operating temperature at Normal conditions	90	°C
Max. conductor operating temperature at Emergency conditions	130	°C
Max. conductor operating temperature at Short circuit conditions	250	°C
Min. bending radius during installation in terms of cable outer diameter	15 Ø	

The above data is approximate and subject to manufacturing tolerance.

We reserve the right to change the above figures as a result of product development and/or changes in standard.

Constructional Data

Conductor		Insulation			Screen	Armour	Packing			Cable Code
Nominal area of conductor	Approx. conductor diameter	Thickness of insulation layers			Approx. metallic screen tape thickness	Tape thickness	Approx. overall diameter	Approx. overall weight	Standard cutting length $\pm 5\%$	
		C.S	XLPE	I.S						
mm ²	mm	Min.	Nom.	Min.	mm	mm	mm	kg / km	m	
25	5.85	0.3	4.5	0.3	0.076	0.50	25.2	738	1000	A316XJ1BBBMRDXXI0MR
35	6.90	0.3	4.5	0.3	0.076	0.50	26.2	804	1000	A317XJ1BBBMRDXXI0MR
50	8.10	0.3	4.5	0.3	0.076	0.50	27.6	900	1000	A318XJ1BBBMRDXXI0MR
70	9.70	0.3	4.5	0.3	0.076	0.50	29.2	1021	1000	A319XJ1BBBMRDXXI0MR
95	11.30	0.3	4.5	0.3	0.076	0.50	31.0	1168	1000	A345XJ1BBBMRDXXI0MR
120	12.60	0.3	4.5	0.3	0.076	0.50	32.3	1293	1000	A346XJ1BBBMRDXXI0MR
150	14.10	0.3	4.5	0.3	0.076	0.50	34.0	1442	1000	A347XJ1BBBMRDXXI0MR
185	15.80	0.3	4.5	0.3	0.076	0.50	35.7	1614	1000	A348XJ1BBBMRDXXI0MR
240	18.10	0.3	4.5	0.3	0.076	0.50	38.2	1883	1000	A349XJ1BBBMRDXXI0MR
300	20.50	0.3	4.5	0.3	0.076	0.50	40.8	2166	1000	A350XJ1BBBMRDXXI0MR
400	23.10	0.3	4.5	0.3	0.076	0.50	43.8	2551	1000	A351XJ1BBBMRDXXI0MR
500	26.50	0.3	4.5	0.3	0.076	0.50	47.6	3046	1000	A352XJ1BBBMRDXXI0MR
630	30.05	0.3	4.5	0.3	0.076	0.50	51.4	3606	1000	A353XJ1BBBMRDXXI0MR
800	34.00	0.3	4.5	0.3	0.076	0.50	55.9	4374	500	A354XJ1BBBMRDXXI0MF
1000	40.00	0.3	4.5	0.3	0.076	0.50	63.9	5417	500	A755XJ1BBBMRDXXI0MF

Electrical Data

Nominal area of conductor	Electrical Characteristics					Continuous Current Ratings						
	Max. Conductor Resistance		Reactance (60 Hz)	Impedance (90 °C, 60 Hz)	Capacitance	Buried direct in the ground		In single-way ducts		In air		
	DC at 20 °C	AC at 90 °C				Trefoil	Flat spaced	Trefoil	Flat touched	Trefoil	Flat touched	Flat spaced
	mm ²	Ω / km	Ω / km	Ω / km	Ω / km	$\mu\text{F} / \text{km}$	A	A	A	A	A	A
25	1.2000	1.5386	0.187	1.550	0.166	98	103	90	91	112	114	133
35	0.8680	1.1130	0.177	1.127	0.183	117	122	108	108	135	139	161
50	0.6410	0.8220	0.166	0.839	0.202	138	143	128	127	163	166	193
70	0.4430	0.5683	0.156	0.589	0.228	168	175	156	156	203	207	241
95	0.3200	0.4107	0.149	0.437	0.253	201	208	187	185	246	252	292
120	0.2530	0.3250	0.144	0.356	0.273	227	235	212	210	284	290	335
150	0.2060	0.2649	0.140	0.299	0.297	254	261	237	235	323	329	380
185	0.1640	0.2113	0.134	0.250	0.324	287	294	269	265	371	378	435
240	0.1250	0.1617	0.128	0.207	0.360	331	337	311	305	439	445	510
300	0.1000	0.1301	0.124	0.180	0.397	374	376	350	342	505	511	582
400	0.0778	0.1023	0.120	0.158	0.438	424	422	399	387	586	590	668
500	0.0605	0.0810	0.116	0.141	0.491	481	472	454	436	682	683	768
630	0.0469	0.0647	0.112	0.129	0.546	540	513	508	479	785	775	858
800	0.0367	0.0529	0.109	0.121	0.610	597	549	560	517	891	867	944
1000	0.0291	0.0387	0.105	0.112	0.725	694	593	635	569	1078	1022	1063

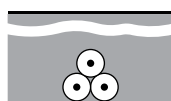

Fig. (a)

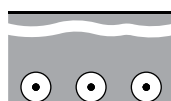

Fig. (b)

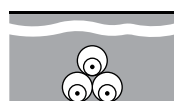

Fig. (c)

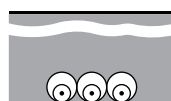

Fig. (d)

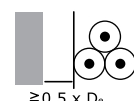

Fig. (e)

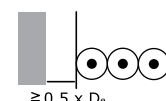

Fig. (f)

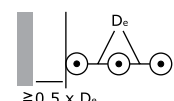

Fig. (g)

Laying Conditions: Ambient air temperature of 40 °C, Ambient ground temperature of 30 °C, Soil thermal resistivity of 1.5 K·m/W, Depth of laying of 0.8 m, and cable screens are bonded at both ends. In case of different laying conditions, appropriate correction (derating) factors from *Annex E* have to be applied to cater for the actual installation conditions.

Three-Core Cables, with Aluminum Conductors, XLPE Insulated, Tape Armoured and PVC Sheathed

APPLICATION

Suitable for installations indoors: mostly in power supply stations and outdoors: in cable ducts, underground, and on cable trays for industries, switch-boards and power stations. Due to the good laying and mechanical characteristics, this cable is suitable when mechanical protection is required or in applications where mechanical damages are expected to occur.

APPLICABLE STANDARDS

alfanar medium voltage cables are designed and tested to meet or exceed the requirements of IEC 60502-2 standard. However, **alfanar** can also supply a range of alternative designs to meet customer-specified requirements.

CABLE CONSTRUCTION

Conductor

Stranded circular compacted aluminum conductor (Class 2).

Conductor Screen

Extruded layer of a cross-linkable semi-conducting compound as a stress control layer.

Insulation

Extruded layer of cross-linked polyethylene (XLPE).

Insulation Screen

Extruded layer of a cross-linkable semi-conducting compound firmly bonded to the insulation.

Metallic Screen

Flat plain copper tape helically applied over the insulation screen with suitable overlap.

Filler

Non-hygroscopic polypropylene filler suitable for the cable's operating temperature.

Bedding

Extruded layer of Polyvinyl chloride (PVC).

Armouring

Double layer of galvanized steel tapes.

Outer Jacket

Extruded layer of Polyvinyl chloride (PVC).

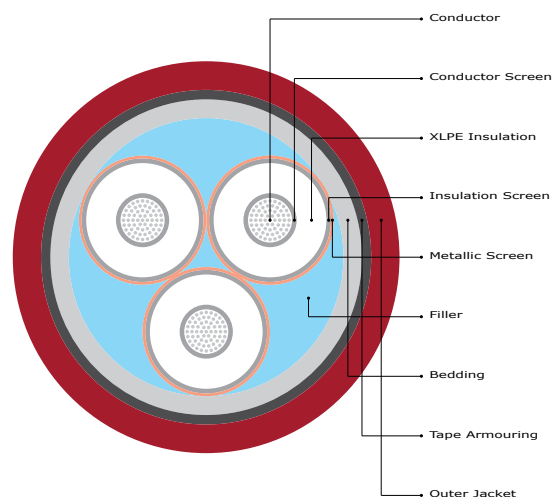

Note: The conductor screen, XLPE insulation and the insulation screen are extruded simultaneously in one process using triple extrusion method (Continuous Vulcanization Line). Triple extrusion method not only assures clean interfaces between the insulation and stress control layers, but also assures a construction free of Partial Discharge with high operational reliability.

TECHNICAL DATA

Rated voltage $U_0 / U (U_m)$	8.7 / 15 (17.5)	kV
Impulse test voltage (peak value)	95	kV
Power frequency test voltage for 5 minutes	30.5	kV
Max. conductor operating temperature at Normal conditions	90	°C
Max. conductor operating temperature at Emergency conditions	130	°C
Max. conductor operating temperature at Short circuit conditions	250	°C
Min. bending radius during installation in terms of cable outer diameter	12 \emptyset	

Constructional Data

Conductor		Insulation			Screen	Armour	Packing			Cable Code
Nominal area of conductor	Approx. conductor diameter	Thickness of insulation layers			Approx. metallic screen tape thickness	Tape thickness	Approx. overall diameter	Approx. overall weight	Standard cutting length $\pm 5\%$	
		C.S.	XLPE	I.S.						
mm ²	mm	Min.	Nom.	Min.	mm	mm	mm	kg / km	m	
25	5.85	0.3	4.5	0.3	0.076	0.50	47.5	2612	1000	A316XJ3BBGMRDXXI0MR
35	6.90	0.3	4.5	0.3	0.076	0.50	49.8	2865	1000	A317XJ3BBGMRDXXI0MR
50	8.10	0.3	4.5	0.3	0.076	0.50	52.8	3217	1000	A318XJ3BBGMRDXXI0MR
70	9.70	0.3	4.5	0.3	0.076	0.50	56.5	3678	1000	A319XJ3BBGMRDXXI0MR
95	11.30	0.3	4.5	0.3	0.076	0.50	60.5	4233	500	A345XJ3BBGMRDXXI0MF
120	12.60	0.3	4.5	0.3	0.076	0.50	63.7	4734	500	A346XJ3BBGMRDXXI0MF
150	14.10	0.3	4.5	0.3	0.076	0.50	67.2	5249	500	A347XJ3BBGMRDXXI0MF
185	15.80	0.3	4.5	0.3	0.076	0.50	71.2	5922	500	A348XJ3BBGMRDXXI0MF
240	18.10	0.3	4.5	0.3	0.076	0.50	76.8	6927	500	A349XJ3BBGMRDXXI0MF
300	20.50	0.3	4.5	0.3	0.076	0.80	83.8	8766	400	A350XJ3BBGMRDXXI0MU
400	23.10	0.3	4.5	0.3	0.076	0.80	90.0	10157	350	A351XJ3BBGMRDXXI0MV

Electrical Data

Nominal area of conductor	Electrical Characteristics					Continuous Current Ratings		
	Max. Conductor Resistance		Reactance (60 Hz)	Impedance (90 °C, 60 Hz)	Capacitance	Buried direct in the ground	In a buried duct	In air
	DC at 20 °C	AC at 90 °C				Fig. (a)	Fig. (b)	Fig. (c)
mm ²	Ω / km	Ω / km	Ω / km	Ω / km	$\mu\text{F} / \text{km}$	A	A	A
25	1.2000	1.5386	0.161	1.547	0.166	95	81	103
35	0.8680	1.1130	0.153	1.123	0.183	113	97	124
50	0.6410	0.8221	0.142	0.834	0.202	133	114	147
70	0.4430	0.5684	0.134	0.584	0.228	162	140	183
95	0.3200	0.4109	0.128	0.430	0.253	192	168	221
120	0.2530	0.3252	0.124	0.348	0.273	218	191	253
150	0.2060	0.2652	0.120	0.291	0.297	244	215	287
185	0.1640	0.2117	0.115	0.241	0.324	275	244	328
240	0.1250	0.1622	0.111	0.197	0.360	318	284	385
300	0.1000	0.1308	0.107	0.169	0.397	357	321	439
400	0.0778	0.1032	0.104	0.146	0.438	406	368	508

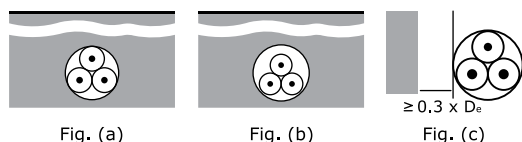

Fig. (a)

Fig. (b)

Fig. (c)

Laying Conditions: Ambient air temperature of 40 °C, Ambient ground temperature of 30 °C, Soil thermal resistivity of 1.5 K·m/W, Depth of laying of 0.8 m. and cable screens are bonded at both ends. In case of different laying conditions, appropriate correction (derating) factors from *Annex E* have to be applied to cater for the actual installation conditions.

Single-Core Cables, with Aluminum Conductors, XLPE Insulated, Wire Armoured and PVC Sheathed

APPLICATION

Suitable for installations indoors: mostly in power supply stations and outdoors: in cable ducts, underground, and on cable trays for industries, switch-boards and power stations. Due to the good laying and mechanical characteristics, this cable is suitable when mechanical protection is required or in applications where mechanical damages are expected to occur.

APPLICABLE STANDARDS

alfanar medium voltage cables are designed and tested to meet or exceed the requirements of IEC 60502-2 standard and/or BS 6622 standard with rated voltage 8.7 / 15 (17.5) kV. However, **alfanar** can also supply a range of alternative designs to meet customer-specified requirements.

CABLE CONSTRUCTION

Conductor

Stranded circular compacted aluminum conductor (Class 2).

Conductor Screen

Extruded layer of a cross-linkable semi-conducting compound as a stress control layer.

Insulation

Extruded layer of cross-linked polyethylene (XLPE).

Insulation Screen

Extruded layer of a cross-linkable semi-conducting compound firmly bonded to the insulation.

Metallic Screen

Flat plain copper tape helically applied over the insulation screen with suitable overlap.

Bedding

Extruded layer of Polyvinyl chloride (PVC).

Armouring

Single layer of round non-magnetic (aluminum) wires.

Outer Jacket

Extruded layer of Polyvinyl chloride (PVC).

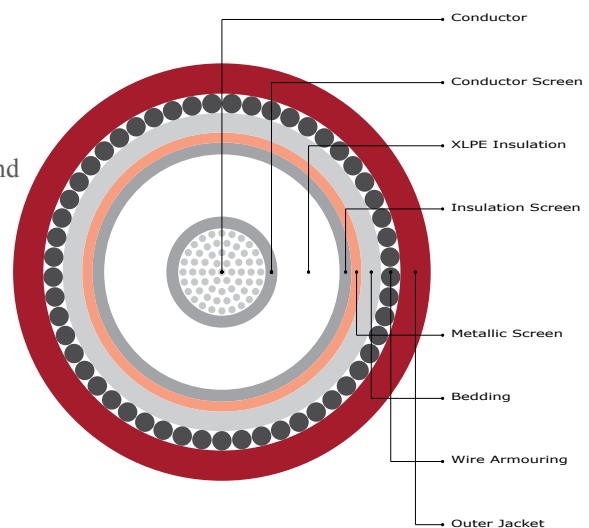

Note: The conductor screen, XLPE insulation and the insulation screen are extruded simultaneously in one process using triple extrusion method (Continuous Vulcanization Line). Triple extrusion method not only assures clean interfaces between the insulation and stress control layers, but also assures a construction free of Partial Discharge with high operational reliability.

TECHNICAL DATA

Rated voltage $U_0 / U (U_m)$	8.7 / 15 (17.5)	kV
Impulse test voltage (peak value)	95	kV
Power frequency test voltage for 5 minutes	30.5	kV
Max. conductor operating temperature at Normal conditions	90	°C
Max. conductor operating temperature at Emergency conditions	130	°C
Max. conductor operating temperature at Short circuit conditions	250	°C
Min. bending radius during installation in terms of cable outer diameter	15 Ø	

The above data is approximate and subject to manufacturing tolerance.

We reserve the right to change the above figures as a result of product development and/or changes in standard.

Constructional Data

Conductor		Insulation			Screen	Armour	Packing			Cable Code
Nominal area of conductor	Approx. conductor diameter	Thickness of insulation layers			Approx. metallic screen tape thickness	Wire diameter	Approx. overall diameter	Approx. overall weight	Standard cutting length $\pm 5\%$	
		C.S	XLPE	I.S						
mm ²	mm	Min.	Nom.	Min.	mm	mm	mm	kg / km	m	
25	5.85	0.3	4.5	0.3	0.076	1.60	26.9	856	1000	A316XJ1BBAMRDXXI0MR
35	6.90	0.3	4.5	0.3	0.076	1.60	28.1	942	1000	A317XJ1BBAMRDXXI0MR
50	8.10	0.3	4.5	0.3	0.076	1.60	29.3	1029	1000	A318XJ1BBAMRDXXI0MR
70	9.70	0.3	4.5	0.3	0.076	1.60	31.1	1174	1000	A319XJ1BBAMRDXXI0MR
95	11.30	0.3	4.5	0.3	0.076	2.00	33.5	1395	1000	A345XJ1BBAMRDXXI0MR
120	12.60	0.3	4.5	0.3	0.076	2.00	35.0	1548	1000	A346XJ1BBAMRDXXI0MR
150	14.10	0.3	4.5	0.3	0.076	2.00	36.5	1691	1000	A347XJ1BBAMRDXXI0MR
185	15.80	0.3	4.5	0.3	0.076	2.00	38.4	1901	1000	A348XJ1BBAMRDXXI0MR
240	18.10	0.3	4.5	0.3	0.076	2.00	40.9	2185	1000	A349XJ1BBAMRDXXI0MR
300	20.50	0.3	4.5	0.3	0.076	2.00	43.3	2465	1000	A350XJ1BBAMRDXXI0MR
400	23.10	0.3	4.5	0.3	0.076	2.50	47.5	3045	1000	A351XJ1BBAMRDXXI0MR
500	26.50	0.3	4.5	0.3	0.076	2.50	51.3	3582	1000	A352XJ1BBAMRDXXI0MR
630	30.05	0.3	4.5	0.3	0.076	2.50	55.1	4182	1000	A353XJ1BBAMRDXXI0MR
800	34.00	0.3	4.5	0.3	0.076	2.50	59.6	5000	500	A354XJ1BBAMRDXXI0MF
1000	40.00	0.3	4.5	0.3	0.076	2.50	67.6	6125	500	A755XJ1BBAMRDXXI0MF

Electrical Data

Nominal area of conductor	Electrical Characteristics					Continuous Current Ratings						
	Max. Conductor Resistance		Reactance (60 Hz)	Impedance (90 °C, 60 Hz)	Capacitance	Buried direct in the ground		In single-way ducts		In air		
	DC at 20 °C	AC at 90 °C				Trefoil	Flat spaced	Trefoil	Flat touched	Trefoil	Flat touched	Flat spaced
	mm ²	Ω / km	Ω / km	Ω / km	Ω / km	μ F / km	A	A	A	A	A	A
25	1.2000	1.5386	0.191	1.550	0.166	99	103	92	91	115	117	135
35	0.8680	1.1130	0.182	1.128	0.183	118	121	109	108	139	142	163
50	0.6410	0.8220	0.170	0.839	0.202	139	142	128	127	166	169	194
70	0.4430	0.5683	0.161	0.591	0.228	169	171	156	153	207	210	240
95	0.3200	0.4107	0.155	0.439	0.253	200	200	185	180	250	252	288
120	0.2530	0.3249	0.150	0.358	0.273	225	221	208	200	288	288	326
150	0.2060	0.2649	0.145	0.302	0.297	251	242	230	220	326	324	364
185	0.1640	0.2112	0.139	0.253	0.324	281	266	257	244	372	368	409
240	0.1250	0.1616	0.134	0.210	0.360	321	296	291	272	435	424	467
300	0.1000	0.1300	0.129	0.183	0.397	357	320	322	297	495	477	520
400	0.0778	0.1021	0.126	0.162	0.438	394	344	351	320	562	530	577
500	0.0605	0.0807	0.121	0.146	0.491	437	372	386	347	640	593	643
630	0.0469	0.0643	0.117	0.134	0.546	479	399	421	374	721	656	709
800	0.0367	0.0524	0.114	0.125	0.610	518	425	453	399	800	715	775
1000	0.0291	0.0386	0.109	0.116	0.725	561	463	495	435	908	805	878

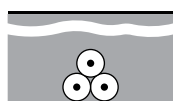

Fig. (a)

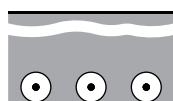

Fig. (b)

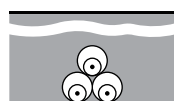

Fig. (c)

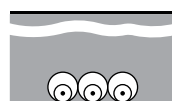

Fig. (d)

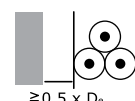

Fig. (e)

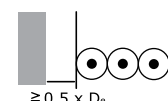

Fig. (f)

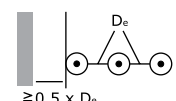

Fig. (g)

Laying Conditions: Ambient air temperature of 40 °C, Ambient ground temperature of 30 °C, Soil thermal resistivity of 1.5 K·m/W, Depth of laying of 0.8 m, and cable screens are bonded at both ends. In case of different laying conditions, appropriate correction (derating) factors from *Annex E* have to be applied to cater for the actual installation conditions.

Three-Core Cables, with Aluminum Conductors, XLPE Insulated, Wire Armoured and PVC Sheathed

APPLICATION

Suitable for installations indoors: mostly in power supply stations and outdoors: in cable ducts, underground, and on cable trays for industries, switch-boards and power stations. Due to the good laying and mechanical characteristics, this cable is suitable when mechanical protection is required or in applications where mechanical damages are expected to occur.

APPLICABLE STANDARDS

alfanar medium voltage cables are designed and tested to meet or exceed the requirements of IEC 60502-2 standard and/or BS 6622 standard with rated voltage 8.7 / 15 (17.5) kV. However, **alfanar** can also supply a range of alternative designs to meet customer-specified requirements.

CABLE CONSTRUCTION

Conductor

Stranded circular compacted aluminum conductor (Class 2).

Conductor Screen

Extruded layer of a cross-linkable semi-conducting compound as a stress control layer.

Insulation

Extruded layer of cross-linked polyethylene (XLPE).

Insulation Screen

Extruded layer of a cross-linkable semi-conducting compound firmly bonded to the insulation.

Metallic Screen

Flat plain copper tape helically applied over the insulation screen with suitable overlap.

Filler

Non-hygroscopic polypropylene filler suitable for the cable's operating temperature.

Bedding

Extruded layer of Polyvinyl chloride (PVC).

Armouring

Single layer of round galvanized steel wires.

Outer Jacket

Extruded layer of Polyvinyl chloride (PVC).

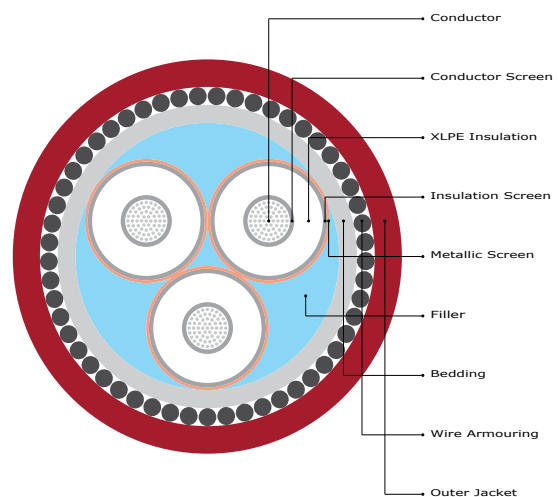

Note: The conductor screen, XLPE insulation and the insulation screen are extruded simultaneously in one process using triple extrusion method (Continuous Vulcanization Line). Triple extrusion method not only assures clean interfaces between the insulation and stress control layers, but also assures a construction free of Partial Discharge with high operational reliability.

TECHNICAL DATA

Rated voltage $U_0 / U (U_m)$	8.7 / 15 (17.5)	kV
Impulse test voltage (peak value)	95	kV
Power frequency test voltage for 5 minutes	30.5	kV
Max. conductor operating temperature at Normal conditions	90	°C
Max. conductor operating temperature at Emergency conditions	130	°C
Max. conductor operating temperature at Short circuit conditions	250	°C
Min. bending radius during installation in terms of cable outer diameter	12 \emptyset	

Constructional Data

Conductor		Insulation			Screen	Armour	Packing			Cable Code
Nominal area of conductor	Approx. conductor diameter	Thickness of insulation layers			Approx. metallic screen tape thickness	Wire diameter	Approx. overall diameter	Approx. overall weight	Standard cutting length $\pm 5\%$	
		C.S.	XLPE	I.S.						
mm ²	mm	Min.	Nom.	Min.	mm	mm	mm	kg / km	m	
25	5.85	0.3	4.5	0.3	0.076	2.50	50.7	4081	1000	A316XJ3BBWMDXXI0MR
35	6.90	0.3	4.5	0.3	0.076	2.50	53.0	4391	1000	A317XJ3BBWMDXXI0MR
50	8.10	0.3	4.5	0.3	0.076	2.50	56.0	4827	1000	A318XJ3BBWMDXXI0MR
70	9.70	0.3	4.5	0.3	0.076	2.50	59.7	5404	1000	A319XJ3BBWMDXXI0MR
95	11.30	0.3	4.5	0.3	0.076	2.50	63.7	6075	500	A345XJ3BBWMDXXI0MF
120	12.60	0.3	4.5	0.3	0.076	2.50	66.9	6698	500	A346XJ3BBWMDXXI0MF
150	14.10	0.3	4.5	0.3	0.076	3.15	72.3	8258	500	A347XJ3BBWMDXXI0MF
185	15.80	0.3	4.5	0.3	0.076	3.15	76.3	9081	500	A348XJ3BBWMDXXI0MF
240	18.10	0.3	4.5	0.3	0.076	3.15	81.9	10354	400	A349XJ3BBWMDXXI0MU
300	20.50	0.3	4.5	0.3	0.076	3.15	87.7	11684	400	A350XJ3BBWMDXXI0MU
400	23.10	0.3	4.5	0.3	0.076	3.15	93.9	13275	350	A351XJ3BBWMDXXI0MV

Electrical Data

Nominal area of conductor	Electrical Characteristics					Continuous Current Ratings		
	Max. Conductor Resistance		Reactance (60 Hz)	Impedance (90 °C, 60 Hz)	Capacitance	Buried direct in the ground	In a buried duct	In air
	DC at 20 °C	AC at 90 °C				Fig. (a)	Fig. (b)	Fig. (c)
mm ²	Ω / km	Ω / km	Ω / km	Ω / km	$\mu\text{F} / \text{km}$	A	A	A
25	1.2000	1.5386	0.161	1.547	0.166	96	82	105
35	0.8680	1.1130	0.153	1.123	0.183	114	98	126
50	0.6410	0.8221	0.142	0.834	0.202	133	116	150
70	0.4430	0.5684	0.134	0.584	0.228	162	142	185
95	0.3200	0.4109	0.128	0.430	0.253	193	169	224
120	0.2530	0.3252	0.124	0.348	0.273	217	192	256
150	0.2060	0.2652	0.120	0.291	0.297	243	215	289
185	0.1640	0.2117	0.115	0.241	0.324	273	243	329
240	0.1250	0.1622	0.111	0.197	0.360	312	280	384
300	0.1000	0.1308	0.107	0.169	0.397	348	314	434
400	0.0778	0.1032	0.104	0.146	0.438	390	354	495

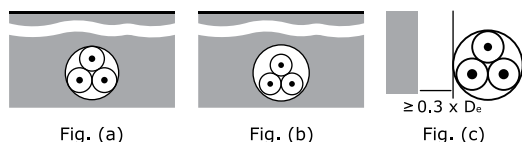

Laying Conditions: Ambient air temperature of 40 °C, Ambient ground temperature of 30 °C, Soil thermal resistivity of 1.5 K·m/W, Depth of laying of 0.8 m. and cable screens are bonded at both ends. In case of different laying conditions, appropriate correction (derating) factors from *Annex E* have to be applied to cater for the actual installation conditions.

Single-Core Cables, with Copper Conductors, XLPE Insulated and PVC Sheathed

APPLICATION

Suitable for installations indoors: mostly in power supply stations and outdoors: in cable ducts, underground, and on cable trays for industries, switch-boards and power stations.

APPLICABLE STANDARDS

alfanar medium voltage cables are designed and tested to meet or exceed the requirements of IEC 60502-2 standard. However, **alfanar** can also supply a range of alternative designs to meet customer-specified requirements.

CABLE CONSTRUCTION

Conductor

Plain annealed stranded circular compacted copper conductor (Class 2).

Conductor Screen

Extruded layer of a cross-linkable semi-conducting compound as a stress control layer.

Insulation

Extruded layer of cross-linked polyethylene (XLPE).

Insulation Screen

Extruded layer of a cross-linkable semi-conducting compound firmly bonded to the insulation.

Metallic Screen

Flat plain copper tape helically applied over the insulation screen with suitable overlap.

Outer Jacket

Extruded layer of Polyvinyl chloride (PVC).

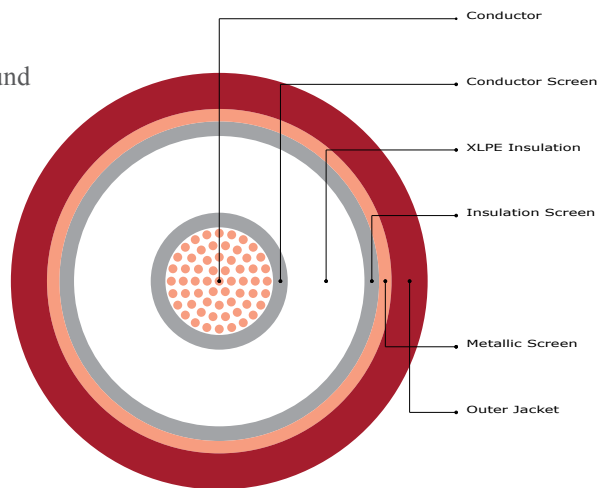

Note: The conductor screen, XLPE insulation and the insulation screen are extruded simultaneously in one process using triple extrusion method (Continuous Vulcanization Line). Triple extrusion method not only assures clean interfaces between the insulation and stress control layers, but also assures a construction free of Partial Discharge with high operational reliability.

TECHNICAL DATA

Rated voltage $U_0 / U (U_m)$	12 / 20 (24)	kV
Impulse test voltage (peak value)	125	kV
Power frequency test voltage for 5 minutes	42	kV
Max. conductor operating temperature at Normal conditions	90	°C
Max. conductor operating temperature at Emergency conditions	130	°C
Max. conductor operating temperature at Short circuit conditions	250	°C
Min. bending radius during installation in terms of cable outer diameter	20 Ø	

The above data is approximate and subject to manufacturing tolerance.

We reserve the right to change the above figures as a result of product development and/or changes in standard.

Constructional Data

Conductor		Insulation			Screen	Armour	Packing			Cable Code
Nominal area of conductor	Approx. conductor diameter	Thickness of insulation layers			Approx. metallic screen tape thickness	N / A	Approx. overall diameter	Approx. overall weight	Standard cutting length $\pm 5\%$	
		C.S	XLPE	I.S						
mm ²	mm	Min.	Nom.	Min.	mm	mm	mm	kg / km	m	
35	6.90	0.3	5.5	0.3	0.076	-	23.6	807	1000	C317XK1BB0MRDXXI0MR
50	8.10	0.3	5.5	0.3	0.076	-	25.0	970	1000	C318XK1BB0MRDXXI0MR
70	9.70	0.3	5.5	0.3	0.076	-	26.6	1202	1000	C319XK1BB0MRDXXI0MR
95	11.30	0.3	5.5	0.3	0.076	-	28.4	1489	1000	C345XK1BB0MRDXXI0MR
120	12.60	0.3	5.5	0.3	0.076	-	29.7	1758	1000	C346XK1BB0MRDXXI0MR
150	14.10	0.3	5.5	0.3	0.076	-	31.4	2047	1000	C347XK1BB0MRDXXI0MR
185	15.80	0.3	5.5	0.3	0.076	-	33.1	2449	1000	C348XK1BB0MRDXXI0MR
240	18.10	0.3	5.5	0.3	0.076	-	35.6	3041	1000	C349XK1BB0MRDXXI0MR
300	20.50	0.3	5.5	0.3	0.076	-	38.2	3683	1000	C350XK1BB0MRDXXI0MR
400	23.10	0.3	5.5	0.3	0.076	-	41.0	4550	1000	C351XK1BB0MRDXXI0MR
500	26.50	0.3	5.5	0.3	0.076	-	44.6	5728	500	C352XK1BB0MRDXXI0MF
630	30.05	0.3	5.5	0.3	0.076	-	48.4	3122	500	C353XK1BB0MRDXXI0MF
800	34.00	0.3	5.5	0.3	0.076	-	52.7	8917	500	C354XK1BB0MRDXXI0MF
1000	40.00	0.3	5.5	0.3	0.076	-	60.5	11201	500	C755XK1BB0MRDXXI0MF

Electrical Data

Nominal area of conductor	Electrical Characteristics					Continuous Current Ratings						
	Max. Conductor Resistance		Reactance (60 Hz)	Impedance (90 °C, 60 Hz)	Capacitance	Buried direct in the ground		In single-way ducts		In air		
	DC at 20 °C	AC at 90 °C				Trefoil	Flat spaced	Trefoil	Flat touched	Trefoil	Flat touched	Flat spaced
	mm ²	Ω / km	Ω / km	Ω / km	Ω / km	$\mu\text{F} / \text{km}$	Fig. (a)	Fig. (b)	Fig. (c)	Fig. (d)	Fig. (e)	Fig. (f)
35	0.5240	0.6684	0.169	0.689	0.159	151	157	137	137	170	174	207
50	0.3870	0.4938	0.158	0.519	0.175	178	185	162	162	204	209	249
70	0.2680	0.3423	0.149	0.373	0.196	217	226	198	198	255	262	311
95	0.1930	0.2469	0.143	0.285	0.217	259	269	238	237	311	319	380
120	0.1530	0.1962	0.138	0.240	0.234	293	304	270	269	359	368	436
150	0.1240	0.1595	0.134	0.208	0.254	327	340	303	301	409	419	497
185	0.0991	0.1282	0.128	0.181	0.276	368	382	343	340	470	481	569
240	0.0754	0.0987	0.123	0.158	0.305	425	439	397	393	556	568	669
300	0.0601	0.0800	0.119	0.143	0.336	476	491	448	441	638	651	767
400	0.0470	0.0643	0.115	0.132	0.369	535	550	508	497	735	747	878
500	0.0366	0.0523	0.111	0.123	0.413	599	612	573	557	846	856	1007
630	0.0283	0.0432	0.108	0.126	0.459	664	675	643	618	963	969	1140
800	0.0221	0.0367	0.105	0.111	0.511	725	733	709	676	1081	1080	1271
1000	0.0176	0.0247	0.101	0.104	0.605	891	829	842	782	1387	1359	1503

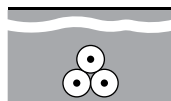

Fig. (a)

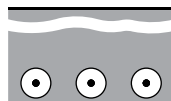

Fig. (b)

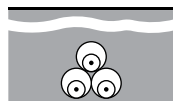

Fig. (c)

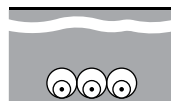

Fig. (d)

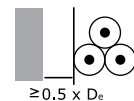

Fig. (e)

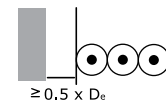

Fig. (f)

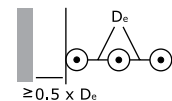

Fig. (g)

Laying Conditions: Ambient air temperature of 40 °C, Ambient ground temperature of 30 °C, Soil thermal resistivity of 1.5 K·m/W, Depth of laying of 0.8 m, and cable screens are bonded at both ends. In case of different laying conditions, appropriate correction (derating) factors from *Annex E* have to be applied to cater for the actual installation conditions.

Three-Core Cables, with Copper Conductors, XLPE Insulated and PVC Sheathed

APPLICATION

Suitable for installations indoors: mostly in power supply stations and outdoors: in cable ducts, underground, and on cable trays for industries, switch-boards and power stations.

APPLICABLE STANDARDS

alfanar medium voltage cables are designed and tested to meet or exceed the requirements of IEC 60502-2 standard. However, **alfanar** can also supply a range of alternative designs to meet customer-specified requirements.

CABLE CONSTRUCTION

Conductor

Plain annealed stranded circular compacted copper conductor (Class 2).

Conductor Screen

Extruded layer of a cross-linkable semi-conducting compound as a stress control layer.

Insulation

Extruded layer of cross-linked polyethylene (XLPE).

Insulation Screen

Extruded layer of a cross-linkable semi-conducting compound firmly bonded to the insulation.

Metallic Screen

Flat plain copper tape helically applied over the insulation screen with suitable overlap.

Filler

Non-hygroscopic polypropylene filler suitable for the cable's operating temperature.

Outer Jacket

Extruded layer of Polyvinyl chloride (PVC).

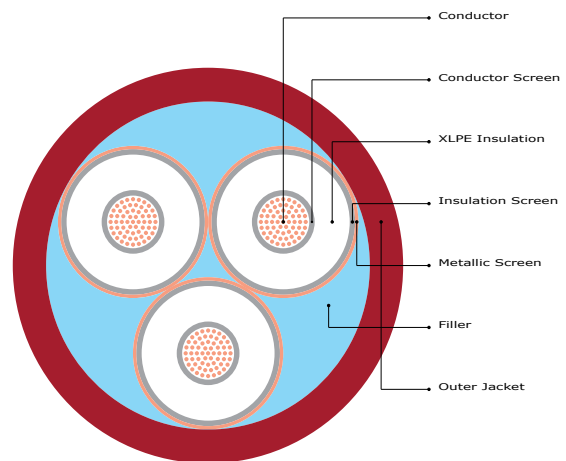

Note: The conductor screen, XLPE insulation and the insulation screen are extruded simultaneously in one process using triple extrusion method (Continuous Vulcanization Line). Triple extrusion method not only assures clean interfaces between the insulation and stress control layers, but also assures a construction free of Partial Discharge with high operational reliability.

TECHNICAL DATA

Rated voltage $U_0 / U (U_m)$	12 / 20 (24)	kV
Impulse test voltage (peak value)	125	kV
Power frequency test voltage for 5 minutes	42	kV
Max. conductor operating temperature at Normal conditions	90	°C
Max. conductor operating temperature at Emergency conditions	130	°C
Max. conductor operating temperature at Short circuit conditions	250	°C
Min. bending radius during installation in terms of cable outer diameter	15 Ø	

The above data is approximate and subject to manufacturing tolerance.

We reserve the right to change the above figures as a result of product development and/or changes in standard.

Constructional Data

Conductor		Insulation			Screen	Armour	Packing			Cable Code
Nominal area of conductor	Approx. conductor diameter	Thickness of insulation layers			Approx. metallic screen tape thickness	N/A	Approx. overall diameter	Approx. overall weight	Standard cutting length $\pm 5\%$	
		C.S	XLPE	I.S						
mm ²	mm	Min.	Nom.	Min.	mm	mm	mm	kg / km	m	
35	6.90	0.3	5.5	0.3	0.076	-	49.3	2729	1000	C317XK3BB0MRDXXI0MR
50	8.10	0.3	5.5	0.3	0.076	-	52.1	3240	1000	C318XK3BB0MRDXXI0MR
70	9.70	0.3	5.5	0.3	0.076	-	55.8	4011	1000	C319XK3BB0MRDXXI0MR
95	11.30	0.3	5.5	0.3	0.076	-	59.4	4911	500	C345XK3BB0MRDXXI0MF
120	12.60	0.3	5.5	0.3	0.076	-	62.4	5790	500	C346XK3BB0MRDXXI0MF
150	14.10	0.3	5.5	0.3	0.076	-	65.9	6702	500	C347XK3BB0MRDXXI0MF
185	15.80	0.3	5.5	0.3	0.076	-	70.0	8042	500	C348XK3BB0MRDXXI0MF
240	18.10	0.3	5.5	0.3	0.076	-	75.1	9901	500	C349XK3BB0MRDXXI0MF
300	20.50	0.3	5.5	0.3	0.076	-	80.7	11961	400	C350XK3BB0MRDXXI0MU
400	23.10	0.3	5.5	0.3	0.076	-	86.7	14713	400	C351XK3BB0MRDXXI0MU

Electrical Data

Nominal area of conductor	Electrical Characteristics					Continuous Current Ratings		
	Max. Conductor Resistance		Reactance (60 Hz)	Impedance (90 °C, 60 Hz)	Capacitance	Buried direct in the ground	In a buried duct	In air
	DC at 20 °C	AC at 90 °C				Fig. (a)	Fig. (b)	Fig. (c)
mm ²	Ω / km	Ω / km	Ω / km	Ω / km	$\mu\text{F} / \text{km}$	A	A	A
35	0.5240	0.6684	0.161	0.687	0.159	152	127	171
50	0.3870	0.4939	0.149	0.516	0.175	179	151	204
70	0.2680	0.3423	0.141	0.370	0.196	218	185	254
95	0.1930	0.2470	0.134	0.281	0.217	260	222	309
120	0.1530	0.1963	0.130	0.235	0.234	294	253	355
150	0.1240	0.1597	0.126	0.203	0.254	329	284	403
185	0.0991	0.1285	0.121	0.176	0.276	371	322	462
240	0.0754	0.0991	0.116	0.153	0.305	426	374	542
300	0.0601	0.0805	0.112	0.138	0.336	478	422	619
400	0.0470	0.0650	0.108	0.126	0.369	536	477	708

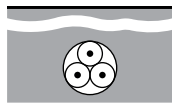

Fig. (a)

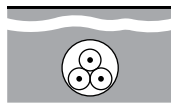

Fig. (b)



Fig. (c)

Laying Conditions: Ambient air temperature of 40 °C, Ambient ground temperature of 30 °C, Soil thermal resistivity of 1.5 K·m/W, Depth of laying of 0.8 m, and cable screens are bonded at both ends. In case of different laying conditions, appropriate correction (derating) factors from *Annex E* have to be applied to cater for the actual installation conditions.

Single-Core Cables, with Copper Conductors, XLPE Insulated, Tape Armoured and PVC Sheathed

APPLICATION

Suitable for installations indoors: mostly in power supply stations and outdoors: in cable ducts, underground, and on cable trays for industries, switch-boards and power stations. Due to the good laying and mechanical characteristics, this cable is suitable when mechanical protection is required or in applications where mechanical damages are expected to occur.

APPLICABLE STANDARDS

alfanar medium voltage cables are designed and tested to meet or exceed the requirements of IEC 60502-2 standard. However, **alfanar** can also supply a range of alternative designs to meet customer-specified requirements.

CABLE CONSTRUCTION

Conductor

Plain annealed stranded circular compacted copper conductor (Class 2).

Conductor Screen

Extruded layer of a cross-linkable semi-conducting compound as a stress control layer.

Insulation

Extruded layer of cross-linked polyethylene (XLPE).

Insulation Screen

Extruded layer of a cross-linkable semi-conducting compound firmly bonded to the insulation.

Metallic Screen

Flat plain copper tape helically applied over the insulation screen with suitable overlap.

Bedding

Extruded layer of Polyvinyl chloride (PVC).

Armouring

Double layer of non-magnetic (aluminum) tapes.

Outer Jacket

Extruded layer of Polyvinyl chloride (PVC).

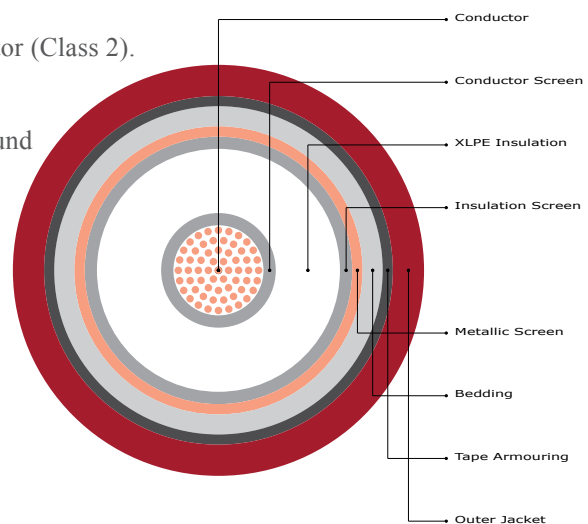

Note: The conductor screen, XLPE insulation and the insulation screen are extruded simultaneously in one process using triple extrusion method (Continuous Vulcanization Line). Triple extrusion method not only assures clean interfaces between the insulation and stress control layers, but also assures a construction free of Partial Discharge with high operational reliability.

TECHNICAL DATA

Rated voltage $U_0 / U (U_m)$	12 / 20 (24)	kV
Impulse test voltage (peak value)	125	kV
Power frequency test voltage for 5 minutes	42	kV
Max. conductor operating temperature at Normal conditions	90	°C
Max. conductor operating temperature at Emergency conditions	130	°C
Max. conductor operating temperature at Short circuit conditions	250	°C
Min. bending radius during installation in terms of cable outer diameter	15 Ø	

The above data is approximate and subject to manufacturing tolerance.

We reserve the right to change the above figures as a result of product development and/or changes in standard.

Constructional Data

Conductor		Insulation			Screen	Armour	Packing			Cable Code
Nominal area of conductor	Approx. conductor diameter	Thickness of insulation layers			Approx. metallic screen tape thickness	Tape thickness	Approx. overall diameter	Approx. overall weight	Standard cutting length $\pm 5\%$	
		C.S	XLPE	I.S						
mm ²	mm	Min.	Nom.	Min.	mm	mm	mm	kg / km	m	
35	6.90	0.3	5.5	0.3	0.076	0.50	28.4	1135	1000	C317XK1BBBMRDXXI0MR
50	8.10	0.3	5.5	0.3	0.076	0.50	29.6	1300	1000	C318XK1BBBMRDXXI0MR
70	9.70	0.3	5.5	0.3	0.076	0.50	31.4	1568	1000	C319XK1BBBMRDXXI0MR
95	11.30	0.3	5.5	0.3	0.076	0.50	33.0	1861	1000	C345XK1BBBMRDXXI0MR
120	12.60	0.3	5.5	0.3	0.076	0.50	34.5	2163	1000	C346XK1BBBMRDXXI0MR
150	14.10	0.3	5.5	0.3	0.076	0.50	36.0	2455	1000	C347XK1BBBMRDXXI0MR
185	15.80	0.3	5.5	0.3	0.076	0.50	37.9	2897	1000	C348XK1BBBMRDXXI0MR
240	18.10	0.3	5.5	0.3	0.076	0.50	40.4	3521	1000	C349XK1BBBMRDXXI0MR
300	20.50	0.3	5.5	0.3	0.076	0.50	43.2	4217	1000	C350XK1BBBMRDXXI0MR
400	23.10	0.3	5.5	0.3	0.076	0.50	46.0	5121	1000	C351XK1BBBMRDXXI0MR
500	26.50	0.3	5.5	0.3	0.076	0.50	49.8	6370	500	C352XK1BBBMRDXXI0MF
630	30.05	0.3	5.5	0.3	0.076	0.50	53.8	7779	500	C353XK1BBBMRDXXI0MF
800	34.00	0.3	5.5	0.3	0.076	0.50	58.1	9698	500	C354XK1BBBMRDXXI0MF
1000	40.00	0.3	5.5	0.3	0.076	0.50	65.9	12093	500	C755XK1BBBMRDXXI0MF

Electrical Data

Nominal area of conductor	Electrical Characteristics					Continuous Current Ratings						
	Max. Conductor Resistance		Reactance (60 Hz)	Impedance (90 °C, 60 Hz)	Capacitance	Buried direct in the ground		In single-way ducts		In air		
	DC at 20 °C	AC at 90 °C				Trefoil	Flat spaced	Trefoil	Flat touched	Trefoil	Flat touched	Flat spaced
	mm ²	Ω / km	Ω / km	Ω / km	Ω / km	$\mu\text{F} / \text{km}$	A	A	A	A	A	A
35	0.5240	0.6684	0.183	0.693	0.159	151	157	139	139	175	178	207
50	0.3870	0.4938	0.171	0.523	0.175	178	184	164	163	209	214	248
70	0.2680	0.3422	0.162	0.379	0.196	217	224	200	199	261	266	308
95	0.1930	0.2468	0.154	0.291	0.217	258	265	239	237	317	323	373
120	0.1530	0.1960	0.149	0.246	0.234	291	298	271	267	364	370	426
150	0.1240	0.1594	0.144	0.215	0.254	326	331	303	298	414	420	482
185	0.0991	0.1280	0.138	0.188	0.276	366	369	341	334	474	480	548
240	0.0754	0.0984	0.133	0.165	0.305	421	419	393	381	558	562	639
300	0.0601	0.0796	0.128	0.151	0.336	473	464	441	425	639	640	723
400	0.0470	0.0638	0.124	0.139	0.369	530	513	496	473	733	730	817
500	0.0366	0.0517	0.119	0.130	0.413	592	564	556	524	841	830	924
630	0.0283	0.0424	0.116	0.123	0.459	652	597	610	562	949	921	1006
800	0.0221	0.0358	0.112	0.118	0.511	705	622	657	591	1054	1005	1080
1000	0.0176	0.0245	0.107	0.110	0.605	831	662	743	643	1296	1188	1201

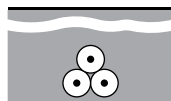

Fig. (a)

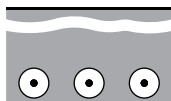

Fig. (b)

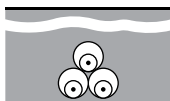

Fig. (c)

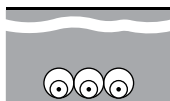

Fig. (d)

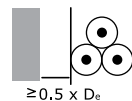

Fig. (e)



Fig. (f)

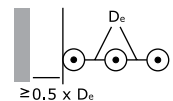

Fig. (g)

Laying Conditions: Ambient air temperature of 40 °C, Ambient ground temperature of 30 °C, Soil thermal resistivity of 1.5 K·m/W, Depth of laying of 0.8 m, and cable screens are bonded at both ends. In case of different laying conditions, appropriate correction (derating) factors from *Annex E* have to be applied to cater for the actual installation conditions.

Three-Core Cables, with Copper Conductors, XLPE Insulated, Tape Armoured and PVC Sheathed

APPLICATION

Suitable for installations indoors: mostly in power supply stations and outdoors: in cable ducts, underground, and on cable trays for industries, switch-boards and power stations. Due to the good laying and mechanical characteristics, this cable is suitable when mechanical protection is required or in applications where mechanical damages are expected to occur.

APPLICABLE STANDARDS

alfanar medium voltage cables are designed and tested to meet or exceed the requirements of IEC 60502-2 standard. However, **alfanar** can also supply a range of alternative designs to meet customer-specified requirements.

CABLE CONSTRUCTION

Conductor

Plain annealed stranded circular compacted copper conductor (Class 2).

Conductor Screen

Extruded layer of a cross-linkable semi-conducting compound as a stress control layer.

Insulation

Extruded layer of cross-linked polyethylene (XLPE).

Insulation Screen

Extruded layer of a cross-linkable semi-conducting compound firmly bonded to the insulation.

Metallic Screen

Flat plain copper tape helically applied over the insulation screen with suitable overlap.

Filler

Non-hygroscopic polypropylene filler suitable for the cable's operating temperature.

Bedding

Extruded layer of Polyvinyl chloride (PVC).

Armouring

Double layer of galvanized steel tapes.

Outer Jacket

Extruded layer of Polyvinyl chloride (PVC).

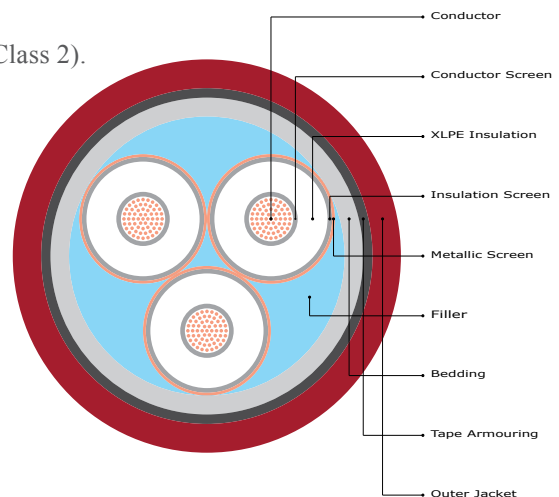

Note: The conductor screen, XLPE insulation and the insulation screen are extruded simultaneously in one process using triple extrusion method (Continuous Vulcanization Line). Triple extrusion method not only assures clean interfaces between the insulation and stress control layers, but also assures a construction free of Partial Discharge with high operational reliability.

TECHNICAL DATA

Rated voltage $U_0 / U (U_m)$	12 / 20 (24)	kV
Impulse test voltage (peak value)	125	kV
Power frequency test voltage for 5 minutes	42	kV
Max. conductor operating temperature at Normal conditions	90	°C
Max. conductor operating temperature at Emergency conditions	130	°C
Max. conductor operating temperature at Short circuit conditions	250	°C
Min. bending radius during installation in terms of cable outer diameter	12 Ø	

Constructional Data

Conductor		Insulation			Screen	Armour	Packing			Cable Code
Nominal area of conductor	Approx. conductor diameter	Thickness of insulation layers			Approx. metallic screen tape thickness	Tape thickness	Approx. overall diameter	Approx. overall weight	Standard cutting length $\pm 5\%$	
		C.S.	XLPE	I.S.						
mm ²	mm	Min.	Nom.	Min.	mm	mm	mm	kg / km	m	
35	6.90	0.3	5.5	0.3	0.076	0.50	54.7	3979	500	C317XK3BBGMRDXXI0MF
50	8.10	0.3	5.5	0.3	0.076	0.50	57.7	4589	500	C318XK3BBGMRDXXI0MF
70	9.70	0.3	5.5	0.3	0.076	0.50	61.4	5452	500	C319XK3BBGMRDXXI0MF
95	11.30	0.3	5.5	0.3	0.076	0.50	65.2	6475	500	C345XK3BBGMRDXXI0MF
120	12.60	0.3	5.5	0.3	0.076	0.50	68.4	7466	500	C346XK3BBGMRDXXI0MF
150	14.10	0.3	5.5	0.3	0.076	0.50	71.9	8468	500	C347XK3BBGMRDXXI0MF
185	15.80	0.3	5.5	0.3	0.076	0.50	76.2	9951	500	C348XK3BBGMRDXXI0MF
240	18.10	0.3	5.5	0.3	0.076	0.80	82.9	12791	500	C349XK3BBGMRDXXI0MF
300	20.50	0.3	5.5	0.3	0.076	0.80	88.5	15060	400	C350XK3BBGMRDXXI0MU
400	23.10	0.3	5.5	0.3	0.076	0.80	94.9	18128	350	C351XK3BBGMRDXXI0MV

Electrical Data

Nominal area of conductor	Electrical Characteristics					Continuous Current Ratings		
	Max. Conductor Resistance		Reactance (60 Hz)	Impedance (90 °C, 60 Hz)	Capacitance	Buried direct in the ground	In a buried duct	In air
	DC at 20 °C	AC at 90 °C				Fig. (a)	Fig. (b)	Fig. (c)
mm ²	Ω / km	Ω / km	Ω / km	Ω / km	$\mu\text{F} / \text{km}$	A	A	A
35	0.5240	0.6684	0.161	0.687	0.159	146	125	160
50	0.3870	0.4939	0.149	0.516	0.175	171	147	190
70	0.2680	0.3423	0.141	0.370	0.196	208	180	235
95	0.1930	0.2470	0.134	0.281	0.217	248	216	285
120	0.1530	0.1963	0.130	0.235	0.234	280	245	325
150	0.1240	0.1597	0.126	0.203	0.254	313	276	369
185	0.0991	0.1285	0.121	0.176	0.276	352	312	419
240	0.0754	0.0991	0.116	0.153	0.305	404	360	489
300	0.0601	0.0805	0.112	0.138	0.336	451	405	555
400	0.0470	0.0650	0.108	0.126	0.369	506	458	633

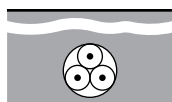

Fig. (a)

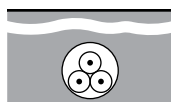

Fig. (b)



Fig. (c)

Laying Conditions: Ambient air temperature of 40 °C, Ambient ground temperature of 30 °C, Soil thermal resistivity of 1.5 K·m/W, Depth of laying of 0.8 m. and cable screens are bonded at both ends. In case of different laying conditions, appropriate correction (derating) factors from *Annex E* have to be applied to cater for the actual installation conditions.

Single-Core Cables, with Copper Conductors, XLPE Insulated, Wire Armoured and PVC Sheathed

APPLICATION

Suitable for installations indoors: mostly in power supply stations and outdoors: in cable ducts, underground, and on cable trays for industries, switch-boards and power stations. Due to the good laying and mechanical characteristics, this cable is suitable when mechanical protection is required or in applications where mechanical damages are expected to occur.

APPLICABLE STANDARDS

alfanar medium voltage cables are designed and tested to meet or exceed the requirements of IEC 60502-2 standard and/or BS 6622 standard with rated voltage 12.7 / 22 (24) kV. However, **alfanar** can also supply a range of alternative designs to meet customer-specified requirements.

CABLE CONSTRUCTION

Conductor

Plain annealed stranded circular compacted copper conductor (Class 2).

Conductor Screen

Extruded layer of a cross-linkable semi-conducting compound as a stress control layer.

Insulation

Extruded layer of cross-linked polyethylene (XLPE).

Insulation Screen

Extruded layer of a cross-linkable semi-conducting compound firmly bonded to the insulation.

Metallic Screen

Flat plain copper tape helically applied over the insulation screen with suitable overlap.

Bedding

Extruded layer of Polyvinyl chloride (PVC).

Armouring

Single layer of round non-magnetic (aluminum) wires.

Outer Jacket

Extruded layer of Polyvinyl chloride (PVC).

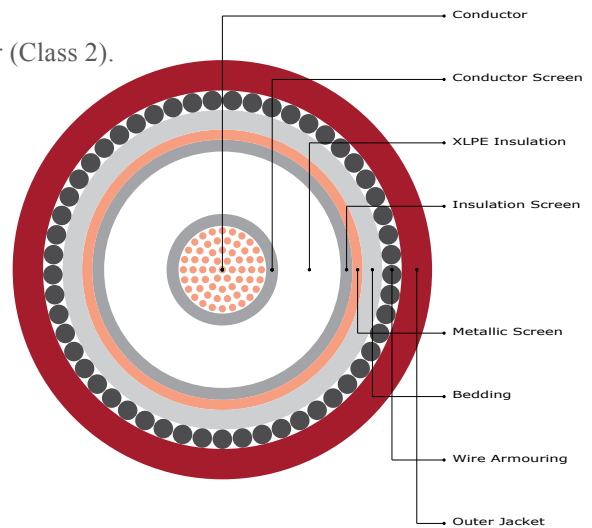

Note: The conductor screen, XLPE insulation and the insulation screen are extruded simultaneously in one process using triple extrusion method (Continuous Vulcanization Line). Triple extrusion method not only assures clean interfaces between the insulation and stress control layers, but also assures a construction free of Partial Discharge with high operational reliability.

TECHNICAL DATA

Rated voltage $U_0 / U (U_m)$	12 / 20 (24)	kV
Impulse test voltage (peak value)	125	kV
Power frequency test voltage for 5 minutes	42	kV
Max. conductor operating temperature at Normal conditions	90	°C
Max. conductor operating temperature at Emergency conditions	130	°C
Max. conductor operating temperature at Short circuit conditions	250	°C
Min. bending radius during installation in terms of cable outer diameter	15 Ø	

The above data is approximate and subject to manufacturing tolerance.

We reserve the right to change the above figures as a result of product development and/or changes in standard.

Constructional Data

Conductor		Insulation			Screen	Armour	Packing			Cable Code
Nominal area of conductor	Approx. conductor diameter	Thickness of insulation layers			Approx. metallic screen tape thickness	Wire diameter	Approx. overall diameter	Approx. overall weight	Standard cutting length $\pm 5\%$	
		C.S.	XLPE	I.S.						
mm ²	mm	Min.	Nom.	Min.	mm	mm	mm	kg / km	m	
35	6.90	0.3	5.5	0.3	0.076	1.60	30.1	1271	1000	C317XK1BBAMRDXXI0MR
50	8.10	0.3	5.5	0.3	0.076	1.60	31.5	1457	1000	C318XK1BBAMRDXXI0MR
70	9.70	0.3	5.5	0.3	0.076	2.00	34.1	1818	1000	C319XK1BBAMRDXXI0MR
95	11.30	0.3	5.5	0.3	0.076	2.00	35.7	2122	1000	C345XK1BBAMRDXXI0MR
120	12.60	0.3	5.5	0.3	0.076	2.00	37.2	2437	1000	C346XK1BBAMRDXXI0MR
150	14.10	0.3	5.5	0.3	0.076	2.00	38.7	2740	1000	C347XK1BBAMRDXXI0MR
185	15.80	0.3	5.5	0.3	0.076	2.00	40.6	3192	1000	C348XK1BBAMRDXXI0MR
240	18.10	0.3	5.5	0.3	0.076	2.00	42.9	3820	1000	C349XK1BBAMRDXXI0MR
300	20.50	0.3	5.5	0.3	0.076	2.50	46.9	4700	1000	C350XK1BBAMRDXXI0MR
400	23.10	0.3	5.5	0.3	0.076	2.50	49.7	5636	1000	C351XK1BBAMRDXXI0MR
500	26.50	0.3	5.5	0.3	0.076	2.50	53.5	6926	500	C352XK1BBAMRDXXI0MF
630	30.05	0.3	5.5	0.3	0.076	2.50	57.5	8374	500	C353XK1BBAMRDXXI0MF
800	34.00	0.3	5.5	0.3	0.076	2.50	61.8	10345	500	C354XK1BBAMRDXXI0MF
1000	40.00	0.3	5.5	0.3	0.076	2.50	69.6	12833	500	C755XK1BBAMRDXXI0MF

Electrical Data

Nominal area of conductor	Electrical Characteristics					Continuous Current Ratings						
	Max. Conductor Resistance		Reactance (60 Hz)	Impedance (90 °C, 60 Hz)	Capacitance	Buried direct in the ground		In single-way ducts		In air		
	DC at 20 °C	AC at 90 °C				Trefoil	Flat spaced	Trefoil	Flat touched	Trefoil	Flat touched	Flat spaced
	mm ²	Ω / km	Ω / km	Ω / km	Ω / km	μF / km	A	A	A	A	A	A
35	0.5240	0.6684	0.188	0.694	0.159	152	155	140	138	179	182	208
50	0.3870	0.4938	0.176	0.524	0.175	178	180	164	161	214	217	247
70	0.2680	0.3422	0.168	0.381	0.196	216	214	198	193	265	267	303
95	0.1930	0.2468	0.160	0.294	0.217	256	249	234	225	320	320	361
120	0.1530	0.1960	0.155	0.250	0.234	286	270	260	246	366	361	402
150	0.1240	0.1593	0.149	0.218	0.254	317	292	286	268	413	403	446
185	0.0991	0.1279	0.143	0.192	0.276	353	317	316	293	469	453	495
240	0.0754	0.0983	0.137	0.169	0.305	399	346	353	321	542	514	555
300	0.0601	0.0794	0.135	0.156	0.336	439	369	385	345	611	571	608
400	0.0470	0.0635	0.129	0.144	0.369	473	388	410	362	679	618	661
500	0.0366	0.0513	0.125	0.135	0.413	513	411	442	386	757	676	722
630	0.0283	0.0420	0.121	0.128	0.459	551	434	472	409	835	733	782
800	0.0221	0.0354	0.117	0.122	0.511	583	456	499	429	907	784	841
1000	0.0176	0.0244	0.112	0.114	0.605	626	493	540	465	1022	876	947

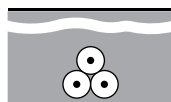

Fig. (a)

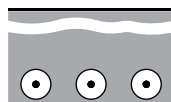

Fig. (b)

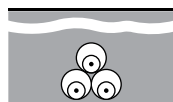

Fig. (c)

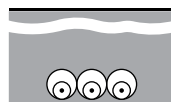

Fig. (d)

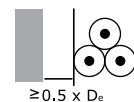

Fig. (e)

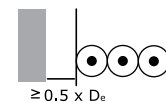

Fig. (f)

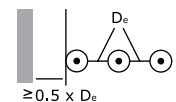

Fig. (g)

Laying Conditions: Ambient air temperature of 40 °C, Ambient ground temperature of 30 °C, Soil thermal resistivity of 1.5 K·m/W, Depth of laying of 0.8 m, and cable screens are bonded at both ends. In case of different laying conditions, appropriate correction (derating) factors from *Annex E* have to be applied to cater for the actual installation conditions.

Three-Core Cables, with Copper Conductors, XLPE Insulated, Wire Armoured and PVC Sheathed

APPLICATION

Suitable for installations indoors: mostly in power supply stations and outdoors: in cable ducts, underground, and on cable trays for industries, switch-boards and power stations. Due to the good laying and mechanical characteristics, this cable is suitable when mechanical protection is required or in applications where mechanical damages are expected to occur.

APPLICABLE STANDARDS

alfanar medium voltage cables are designed and tested to meet or exceed the requirements of IEC 60502-2 standard and/or BS 6622 standard with rated voltage 12.7 / 22 (24) kV. However, **alfanar** can also supply a range of alternative designs to meet customer-specified requirements.

CABLE CONSTRUCTION

Conductor

Plain annealed stranded circular compacted copper conductor (Class 2).

Conductor Screen

Extruded layer of a cross-linkable semi-conducting compound as a stress control layer.

Insulation

Extruded layer of cross-linked polyethylene (XLPE).

Insulation Screen

Extruded layer of a cross-linkable semi-conducting compound firmly bonded to the insulation.

Metallic Screen

Flat plain copper tape helically applied over the insulation screen with suitable overlap.

Filler

Non-hygroscopic polypropylene filler suitable for the cable's operating temperature.

Bedding

Extruded layer of Polyvinyl chloride (PVC).

Armouring

Single layer of round galvanized steel wires.

Outer Jacket

Extruded layer of Polyvinyl chloride (PVC).

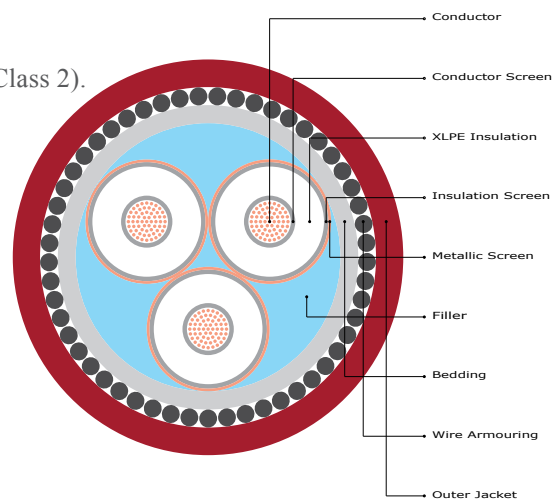

Note: The conductor screen, XLPE insulation and the insulation screen are extruded simultaneously in one process using triple extrusion method (Continuous Vulcanization Line). Triple extrusion method not only assures clean interfaces between the insulation and stress control layers, but also assures a construction free of Partial Discharge with high operational reliability.

TECHNICAL DATA

Rated voltage U_0 / U (Um)	12 / 20 (24)	kV
Impulse test voltage (peak value)	125	kV
Power frequency test voltage for 5 minutes	42	kV
Max. conductor operating temperature at Normal conditions	90	°C
Max. conductor operating temperature at Emergency conditions	130	°C
Max. conductor operating temperature at Short circuit conditions	250	°C
Min. bending radius during installation in terms of cable outer diameter	12 \emptyset	

Constructional Data

Conductor		Insulation			Screen	Armour	Packing			Cable Code
Nominal area of conductor	Approx. conductor diameter	Thickness of insulation layers			Approx. metallic screen tape thickness	Wire diameter	Approx. overall diameter	Approx. overall weight	Standard cutting length $\pm 5\%$	
		C.S.	XLPE	I.S.						
mm ²	mm	Min.	Nom.	Min.	mm	mm	mm	kg / km	m	
35	6.90	0.3	5.5	0.3	0.076	2.50	57.9	5648	500	C317XK3BBWMDXXI0MF
50	8.10	0.3	5.5	0.3	0.076	2.50	60.9	6344	500	C318XK3BBWMDXXI0MF
70	9.70	0.3	5.5	0.3	0.076	2.50	64.6	7323	500	C319XK3BBWMDXXI0MF
95	11.30	0.3	5.5	0.3	0.076	2.50	68.4	8461	500	C345XK3BBWMDXXI0MF
120	12.60	0.3	5.5	0.3	0.076	3.15	73.7	10562	500	C346XK3BBWMDXXI0MF
150	14.10	0.3	5.5	0.3	0.076	3.15	77.2	11722	500	C347XK3BBWMDXXI0MF
185	15.80	0.3	5.5	0.3	0.076	3.15	81.3	13320	500	C348XK3BBWMDXXI0MF
240	18.10	0.3	5.5	0.3	0.076	3.15	86.8	15664	400	C349XK3BBWMDXXI0MU
300	20.50	0.3	5.5	0.3	0.076	3.15	92.4	18139	350	C350XK3BBWMDXXI0MV
400	23.10	0.3	5.5	0.3	0.076	3.15	98.8	21409	300	C351XK3BBWMDXXI0MT

Electrical Data

Nominal area of conductor	Electrical Characteristics					Continuous Current Ratings		
	Max. Conductor Resistance		Reactance (60 Hz)	Impedance (90 °C, 60 Hz)	Capacitance	Buried direct in the ground	In a buried duct	In air
	DC at 20 °C	AC at 90 °C				Fig. (a)	Fig. (b)	Fig. (c)
mm ²	Ω / km	Ω / km	Ω / km	Ω / km	$\mu\text{F} / \text{km}$	A	A	A
35	0.5240	0.6684	0.161	0.687	0.159	146	126	163
50	0.3870	0.4939	0.149	0.516	0.175	171	149	193
70	0.2680	0.3423	0.141	0.370	0.196	208	182	238
95	0.1930	0.2470	0.134	0.281	0.217	247	217	287
120	0.1530	0.1963	0.130	0.235	0.234	278	245	327
150	0.1240	0.1597	0.126	0.203	0.254	309	274	369
185	0.0991	0.1285	0.121	0.176	0.276	345	307	417
240	0.0754	0.0991	0.116	0.153	0.305	391	351	482
300	0.0601	0.0805	0.112	0.138	0.336	431	389	541
400	0.0470	0.0650	0.108	0.126	0.369	475	431	606

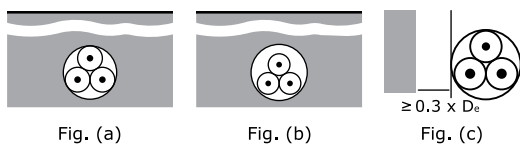

Laying Conditions: Ambient air temperature of 40 °C, Ambient ground temperature of 30 °C, Soil thermal resistivity of 1.5 K·m/W, Depth of laying of 0.8 m. and cable screens are bonded at both ends. In case of different laying conditions, appropriate correction (derating) factors from *Annex E* have to be applied to cater for the actual installation conditions.

Single-Core Cables, with Aluminum Conductors, XLPE Insulated and PVC Sheathed

APPLICATION

Suitable for installations indoors: mostly in power supply stations and outdoors: in cable ducts, underground, and on cable trays for industries, switch-boards and power stations.

APPLICABLE STANDARDS

alfanar medium voltage cables are designed and tested to meet or exceed the requirements of IEC 60502-2 standard. However, **alfanar** can also supply a range of alternative designs to meet customer-specified requirements.

CABLE CONSTRUCTION

Conductor

Stranded circular compacted aluminum conductor (Class 2).

Conductor Screen

Extruded layer of a cross-linkable semi-conducting compound as a stress control layer.

Insulation

Extruded layer of cross-linked polyethylene (XLPE).

Insulation Screen

Extruded layer of a cross-linkable semi-conducting compound firmly bonded to the insulation.

Metallic Screen

Flat plain copper tape helically applied over the insulation screen with suitable overlap.

Outer Jacket

Extruded layer of Polyvinyl chloride (PVC).

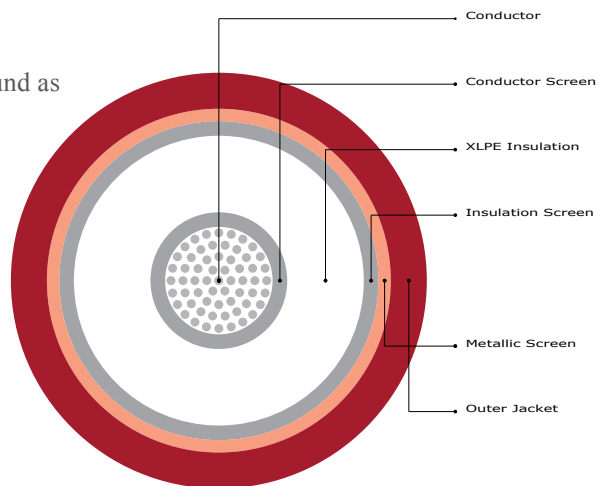

Note: The conductor screen, XLPE insulation and the insulation screen are extruded simultaneously in one process using triple extrusion method (Continuous Vulcanization Line). Triple extrusion method not only assures clean interfaces between the insulation and stress control layers, but also assures a construction free of Partial Discharge with high operational reliability.

TECHNICAL DATA

Rated voltage $U_0 / U (U_m)$	12 / 20 (24)	kV
Impulse test voltage (peak value)	125	kV
Power frequency test voltage for 5 minutes	42	kV
Max. conductor operating temperature at Normal conditions	90	°C
Max. conductor operating temperature at Emergency conditions	130	°C
Max. conductor operating temperature at Short circuit conditions	250	°C
Min. bending radius during installation in terms of cable outer diameter	20 Ø	

The above data is approximate and subject to manufacturing tolerance.

We reserve the right to change the above figures as a result of product development and/or changes in standard.

Constructional Data

Conductor		Insulation			Screen	Armour	Packing			Cable Code
Nominal area of conductor	Approx. conductor diameter	Thickness of insulation layers			Approx. metallic screen tape thickness	N / A	Approx. overall diameter	Approx. overall weight	Standard cutting length $\pm 5\%$	
		C.S	XLPE	I.S						
mm ²	mm	Min.	Nom.	Min.	mm	mm	mm	kg / km	m	
35	6.90	0.3	5.5	0.3	0.076	-	23.6	593	1000	A317XK1BB0MRDXXI0MR
50	8.10	0.3	5.5	0.3	0.076	-	25.0	678	1000	A318XK1BB0MRDXXI0MR
70	9.70	0.3	5.5	0.3	0.076	-	26.6	784	1000	A319XK1BB0MRDXXI0MR
95	11.30	0.3	5.5	0.3	0.076	-	28.4	914	1000	A345XK1BB0MRDXXI0MR
120	12.60	0.3	5.5	0.3	0.076	-	29.7	1027	1000	A346XK1BB0MRDXXI0MR
150	14.10	0.3	5.5	0.3	0.076	-	31.4	1161	1000	A347XK1BB0MRDXXI0MR
185	15.80	0.3	5.5	0.3	0.076	-	33.1	1318	1000	A348XK1BB0MRDXXI0MR
240	18.10	0.3	5.5	0.3	0.076	-	35.6	1564	1000	A349XK1BB0MRDXXI0MR
300	20.50	0.3	5.5	0.3	0.076	-	38.2	1823	1000	A350XK1BB0MRDXXI0MR
400	23.10	0.3	5.5	0.3	0.076	-	41.0	2160	1000	A351XK1BB0MRDXXI0MR
500	26.50	0.3	5.5	0.3	0.076	-	44.6	2598	1000	A352XK1BB0MRDXXI0MR
630	30.05	0.3	5.5	0.3	0.076	-	48.4	3122	1000	A353XK1BB0MRDXXI0MR
800	34.00	0.3	5.5	0.3	0.076	-	52.7	3817	500	A354XK1BB0MRDXXI0MF
1000	40.00	0.3	5.5	0.3	0.076	-	60.5	4746	500	A755XK1BB0MRDXXI0MF

Electrical Data

Nominal area of conductor	Electrical Characteristics					Continuous Current Ratings						
	Max. Conductor Resistance		Reactance (60 Hz)	Impedance (90 °C, 60 Hz)	Capacitance	Buried direct in the ground		In single-way ducts		In air		
	DC at 20 °C	AC at 90 °C				Trefoil	Flat spaced	Trefoil	Flat touched	Trefoil	Flat touched	Flat spaced
	mm ²	Ω / km	Ω / km	Ω / km	Ω / km	$\mu\text{F} / \text{km}$	Fig. (a)	Fig. (b)	Fig. (c)	Fig. (d)	Fig. (e)	Fig. (f)
35	0.8680	1.1130	0.169	1.126	0.159	117	122	106	106	132	135	161
50	0.6410	0.8220	0.158	0.837	0.175	138	144	126	125	158	162	194
70	0.4430	0.5683	0.149	0.588	0.196	168	176	154	154	198	203	242
95	0.3200	0.4108	0.143	0.435	0.217	201	210	184	184	242	248	295
120	0.2530	0.3250	0.138	0.353	0.234	228	237	210	209	279	286	340
150	0.2060	0.2650	0.134	0.297	0.254	254	266	236	235	318	326	387
185	0.1640	0.2114	0.128	0.247	0.276	287	300	268	267	367	376	446
240	0.1250	0.1618	0.123	0.203	0.305	333	346	311	309	435	446	527
300	0.1000	0.1303	0.119	0.177	0.336	375	389	352	349	503	514	606
400	0.0778	0.1025	0.115	0.154	0.369	427	441	403	398	586	598	703
500	0.0605	0.0813	0.111	0.137	0.413	485	499	461	453	685	697	818
630	0.0469	0.0650	0.108	0.126	0.459	547	560	525	511	793	804	941
800	0.0367	0.0533	0.105	0.117	0.511	610	620	590	570	908	916	1070
1000	0.0291	0.0388	0.101	0.108	0.605	728	703	692	657	1131	1127	1265

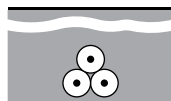

Fig. (a)



Fig. (b)

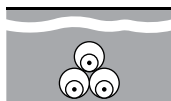

Fig. (c)

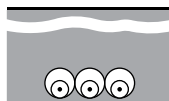

Fig. (d)

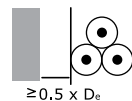

Fig. (e)



Fig. (f)

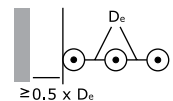

Fig. (g)

Laying Conditions: Ambient air temperature of 40 °C, Ambient ground temperature of 30 °C, Soil thermal resistivity of 1.5 K·m/W, Depth of laying of 0.8 m, and cable screens are bonded at both ends. In case of different laying conditions, appropriate correction (derating) factors from *Annex E* have to be applied to cater for the actual installation conditions.

Three-Core Cables, with Aluminum Conductors, XLPE Insulated and PVC Sheathed

APPLICATION

Suitable for installations indoors: mostly in power supply stations and outdoors: in cable ducts, underground, and on cable trays for industries, switch-boards and power stations.

APPLICABLE STANDARDS

alfanar medium voltage cables are designed and tested to meet or exceed the requirements of IEC 60502-2 standard. However, **alfanar** can also supply a range of alternative designs to meet customer-specified requirements.

CABLE CONSTRUCTION

Conductor

Stranded circular compacted aluminum conductor (Class 2).

Conductor Screen

Extruded layer of a cross-linkable semi-conducting compound as a stress control layer.

Insulation

Extruded layer of cross-linked polyethylene (XLPE).

Insulation Screen

Extruded layer of a cross-linkable semi-conducting compound firmly bonded to the insulation.

Metallic Screen

Flat plain copper tape helically applied over the insulation screen with suitable overlap.

Filler

Non-hygroscopic polypropylene filler suitable for the cable's operating temperature.

Outer Jacket

Extruded layer of Polyvinyl chloride (PVC).

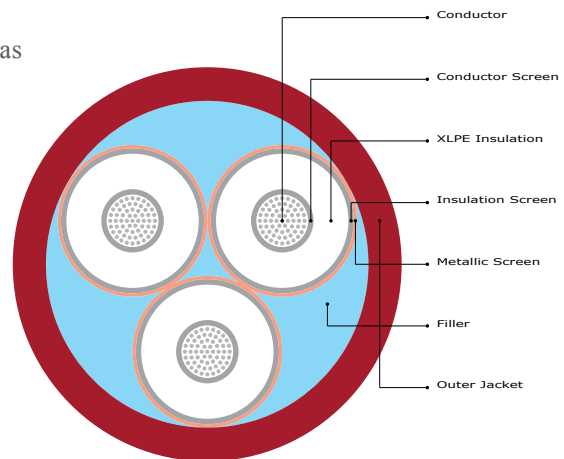

Note: The conductor screen, XLPE insulation and the insulation screen are extruded simultaneously in one process using triple extrusion method (Continuous Vulcanization Line). Triple extrusion method not only assures clean interfaces between the insulation and stress control layers, but also assures a construction free of Partial Discharge with high operational reliability.

TECHNICAL DATA

Rated voltage $U_0 / U (U_m)$	12 / 20 (24)	kV
Impulse test voltage (peak value)	125	kV
Power frequency test voltage for 5 minutes	42	kV
Max. conductor operating temperature at Normal conditions	90	°C
Max. conductor operating temperature at Emergency conditions	130	°C
Max. conductor operating temperature at Short circuit conditions	250	°C
Min. bending radius during installation in terms of cable outer diameter	15 Ø	

The above data is approximate and subject to manufacturing tolerance.

We reserve the right to change the above figures as a result of product development and/or changes in standard.

Constructional Data

Conductor		Insulation			Screen	Armour	Packing			Cable Code
Nominal area of conductor	Approx. conductor diameter	Thickness of insulation layers			Approx. metallic screen tape thickness	N / A	Approx. overall diameter	Approx. overall weight	Standard cutting length $\pm 5\%$	
		C.S.	XLPE	I.S.						
mm ²	mm	Min.	Nom.	Min.	mm	mm	mm	kg / km	m	
35	6.90	0.3	5.5	0.3	0.076	-	49.3	2087	1000	A317XK3BB0MRDXXI0MR
50	8.10	0.3	5.5	0.3	0.076	-	52.1	2363	1000	A318XK3BB0MRDXXI0MR
70	9.70	0.3	5.5	0.3	0.076	-	55.8	2757	1000	A319XK3BB0MRDXXI0MR
95	11.30	0.3	5.5	0.3	0.076	-	59.4	3186	500	A345XK3BB0MRDXXI0MF
120	12.60	0.3	5.5	0.3	0.076	-	62.4	3597	500	A346XK3BB0MRDXXI0MF
150	14.10	0.3	5.5	0.3	0.076	-	65.9	4044	500	A347XK3BB0MRDXXI0MF
185	15.80	0.3	5.5	0.3	0.076	-	70.0	4649	500	A348XK3BB0MRDXXI0MF
240	18.10	0.3	5.5	0.3	0.076	-	75.1	5470	500	A349XK3BB0MRDXXI0MF
300	20.50	0.3	5.5	0.3	0.076	-	80.7	6381	400	A350XK3BB0MRDXXI0MU
400	23.10	0.3	5.5	0.3	0.076	-	86.7	7543	400	A351XK3BB0MRDXXI0MU

Electrical Data

Nominal area of conductor	Electrical Characteristics					Continuous Current Ratings		
	Max. Conductor Resistance		Reactance (60 Hz)	Impedance (90 °C, 60 Hz)	Capacitance	Buried direct in the ground	In a buried duct	In air
	DC at 20 °C	AC at 90 °C				Fig. (a)	Fig. (b)	Fig. (c)
mm ²	Ω / km	Ω / km	Ω / km	Ω / km	$\mu\text{F} / \text{km}$	A	A	A
35	0.8680	1.1130	0.161	1.125	0.159	118	99	132
50	0.6410	0.8221	0.149	0.836	0.175	139	117	158
70	0.4430	0.5683	0.141	0.586	0.196	169	144	197
95	0.3200	0.4108	0.134	0.432	0.217	202	172	240
120	0.2530	0.3251	0.130	0.350	0.234	229	197	276
150	0.2060	0.2651	0.126	0.293	0.254	256	221	313
185	0.1640	0.2116	0.121	0.244	0.276	289	252	361
240	0.1250	0.1621	0.116	0.199	0.305	335	293	425
300	0.1000	0.1306	0.112	0.172	0.336	377	333	488
400	0.0778	0.1030	0.108	0.149	0.369	429	382	566

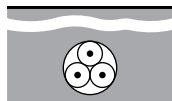

Fig. (a)

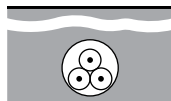

Fig. (b)



Fig. (c)

Laying Conditions: Ambient air temperature of 40 °C, Ambient ground temperature of 30 °C, Soil thermal resistivity of 1.5 K·m/W, Depth of laying of 0.8 m, and cable screens are bonded at both ends. In case of different laying conditions, appropriate correction (derating) factors from *Annex E* have to be applied to cater for the actual installation conditions.

Single-Core Cables, with Aluminum Conductors, XLPE Insulated, Tape Armoured and PVC Sheathed

APPLICATION

Suitable for installations indoors: mostly in power supply stations and outdoors: in cable ducts, underground, and on cable trays for industries, switch-boards and power stations. Due to the good laying and mechanical characteristics, this cable is suitable when mechanical protection is required or in applications where mechanical damages are expected to occur.

APPLICABLE STANDARDS

alfanar medium voltage cables are designed and tested to meet or exceed the requirements of IEC 60502-2 standard. However, **alfanar** can also supply a range of alternative designs to meet customer-specified requirements.

CABLE CONSTRUCTION

Conductor

Stranded circular compacted aluminum conductor (Class 2).

Conductor Screen

Extruded layer of a cross-linkable semi-conducting compound as a stress control layer.

Insulation

Extruded layer of cross-linked polyethylene (XLPE).

Insulation Screen

Extruded layer of a cross-linkable semi-conducting compound firmly bonded to the insulation.

Metallic Screen

Flat plain copper tape helically applied over the insulation screen with suitable overlap.

Bedding

Extruded layer of Polyvinyl chloride (PVC).

Armouring

Double layer of non-magnetic (aluminum) tapes.

Outer Jacket

Extruded layer of Polyvinyl chloride (PVC).

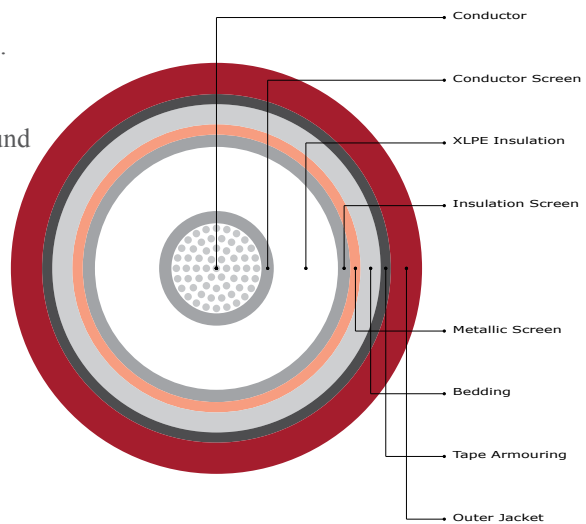

Note: The conductor screen, XLPE insulation and the insulation screen are extruded simultaneously in one process using triple extrusion method (Continuous Vulcanization Line). Triple extrusion method not only assures clean interfaces between the insulation and stress control layers, but also assures a construction free of Partial Discharge with high operational reliability.

TECHNICAL DATA

Rated voltage $U_0 / U (U_m)$	12 / 20 (24)	kV
Impulse test voltage (peak value)	125	kV
Power frequency test voltage for 5 minutes	42	kV
Max. conductor operating temperature at Normal conditions	90	°C
Max. conductor operating temperature at Emergency conditions	130	°C
Max. conductor operating temperature at Short circuit conditions	250	°C
Min. bending radius during installation in terms of cable outer diameter	15 Ø	

The above data is approximate and subject to manufacturing tolerance.

We reserve the right to change the above figures as a result of product development and/or changes in standard.

Constructional Data

Conductor		Insulation			Screen	Armour	Packing			Cable Code
Nominal area of conductor	Approx. conductor diameter	Thickness of insulation layers			Approx. metallic screen tape thickness	Tape thickness	Approx. overall diameter	Approx. overall weight	Standard cutting length $\pm 5\%$	
		C.S.	XLPE	I.S.						
mm ²	mm	Min.	Nom.	Min.	mm	mm	mm	kg / km	m	
35	6.90	0.3	5.5	0.3	0.076	0.50	28.4	921	1000	A317XK1BBBBMRDXXI0MR
50	8.10	0.3	5.5	0.3	0.076	0.50	29.6	1008	1000	A318XK1BBBBMRDXXI0MR
70	9.70	0.3	5.5	0.3	0.076	0.50	31.4	1150	1000	A319XK1BBBBMRDXXI0MR
95	11.30	0.3	5.5	0.3	0.076	0.50	33.0	1286	1000	A345XK1BBBBMRDXXI0MR
120	12.60	0.3	5.5	0.3	0.076	0.50	34.5	1432	1000	A346XK1BBBBMRDXXI0MR
150	14.10	0.3	5.5	0.3	0.076	0.50	36.0	1569	1000	A347XK1BBBBMRDXXI0MR
185	15.80	0.3	5.5	0.3	0.076	0.50	37.9	1766	1000	A348XK1BBBBMRDXXI0MR
240	18.10	0.3	5.5	0.3	0.076	0.50	40.4	2044	1000	A349XK1BBBBMRDXXI0MR
300	20.50	0.3	5.5	0.3	0.076	0.50	43.2	2357	1000	A350XK1BBBBMRDXXI0MR
400	23.10	0.3	5.5	0.3	0.076	0.50	46.0	2731	1000	A351XK1BBBBMRDXXI0MR
500	26.50	0.3	5.5	0.3	0.076	0.50	49.8	3240	1000	A352XK1BBBBMRDXXI0MR
630	30.05	0.3	5.5	0.3	0.076	0.50	53.8	3843	500	A353XK1BBBBMRDXXI0MF
800	34.00	0.3	5.5	0.3	0.076	0.50	58.1	4598	500	A354XK1BBBBMRDXXI0MF
1000	40.00	0.3	5.5	0.3	0.076	0.50	65.9	5638	500	A755XK1BBBBMRDXXI0MF

Electrical Data

Nominal area of conductor	Electrical Characteristics					Continuous Current Ratings						
	Max. Conductor Resistance		Reactance (60 Hz)	Impedance (90 °C, 60 Hz)	Capacitance	Buried direct in the ground		In single-way ducts		In air		
	DC at 20 °C	AC at 90 °C				Trefoil	Flat spaced	Trefoil	Flat touched	Trefoil	Flat touched	Flat spaced
	mm ²	Ω / km	Ω / km	Ω / km	Ω / km	$\mu\text{F} / \text{km}$	A	A	A	A	A	A
35	0.8680	1.1130	0.183	1.128	0.159	117	122	108	108	135	139	161
50	0.6410	0.8220	0.171	0.840	0.175	138	143	128	127	163	166	193
70	0.4430	0.5683	0.162	0.591	0.196	168	175	156	156	203	207	241
95	0.3200	0.4107	0.154	0.439	0.217	201	208	187	185	246	252	292
120	0.2530	0.3250	0.149	0.358	0.234	227	235	212	210	284	290	335
150	0.2060	0.2649	0.144	0.301	0.254	254	261	237	235	323	329	380
185	0.1640	0.2113	0.138	0.252	0.276	287	294	269	265	371	378	435
240	0.1250	0.1616	0.133	0.209	0.305	331	337	311	305	439	445	510
300	0.1000	0.1300	0.128	0.183	0.336	374	376	350	342	505	511	582
400	0.0778	0.1022	0.124	0.160	0.369	424	422	399	387	586	590	668
500	0.0605	0.0808	0.119	0.144	0.413	481	472	454	436	682	683	768
630	0.0469	0.0645	0.116	0.132	0.459	540	513	508	479	785	775	858
800	0.0367	0.0526	0.112	0.124	0.511	597	549	560	517	891	867	944
1000	0.0291	0.0386	0.107	0.114	0.605	694	593	635	569	1078	1022	1063

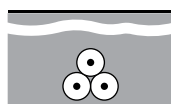

Fig. (a)

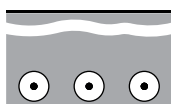

Fig. (b)

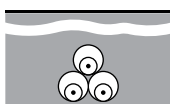

Fig. (c)

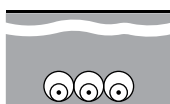

Fig. (d)

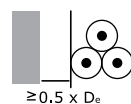

Fig. (e)

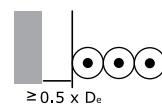

Fig. (f)

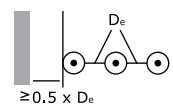

Fig. (g)

Laying Conditions: Ambient air temperature of 40 °C, Ambient ground temperature of 30 °C, Soil thermal resistivity of 1.5 K·m/W, Depth of laying of 0.8 m, and cable screens are bonded at both ends. In case of different laying conditions, appropriate correction (derating) factors from *Annex E* have to be applied to cater for the actual installation conditions.

Three-Core Cables, with Aluminum Conductors, XLPE Insulated, Tape Armoured and PVC Sheathed

APPLICATION

Suitable for installations indoors: mostly in power supply stations and outdoors: in cable ducts, underground, and on cable trays for industries, switch-boards and power stations. Due to the good laying and mechanical characteristics, this cable is suitable when mechanical protection is required or in applications where mechanical damages are expected to occur.

APPLICABLE STANDARDS

alfanar medium voltage cables are designed and tested to meet or exceed the requirements of IEC 60502-2 standard. However, **alfanar** can also supply a range of alternative designs to meet customer-specified requirements.

CABLE CONSTRUCTION

Conductor

Stranded circular compacted aluminum conductor (Class 2).

Conductor Screen

Extruded layer of a cross-linkable semi-conducting compound as a stress control layer.

Insulation

Extruded layer of cross-linked polyethylene (XLPE).

Insulation Screen

Extruded layer of a cross-linkable semi-conducting compound firmly bonded to the insulation.

Metallic Screen

Flat plain copper tape helically applied over the insulation screen with suitable overlap.

Filler

Non-hygroscopic polypropylene filler suitable for the cable's operating temperature.

Bedding

Extruded layer of Polyvinyl chloride (PVC).

Armouring

Double layer of galvanized steel tapes.

Outer Jacket

Extruded layer of Polyvinyl chloride (PVC).

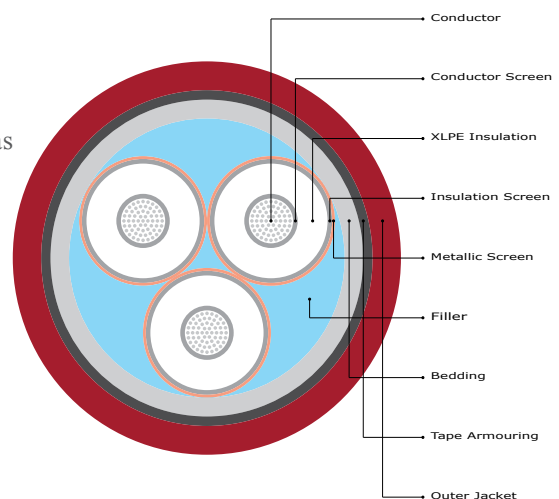

Note: The conductor screen, XLPE insulation and the insulation screen are extruded simultaneously in one process using triple extrusion method (Continuous Vulcanization Line). Triple extrusion method not only assures clean interfaces between the insulation and stress control layers, but also assures a construction free of Partial Discharge with high operational reliability.

TECHNICAL DATA

Rated voltage $U_0 / U (U_m)$	12 / 20 (24)	kV
Impulse test voltage (peak value)	125	kV
Power frequency test voltage for 5 minutes	42	kV
Max. conductor operating temperature at Normal conditions	90	°C
Max. conductor operating temperature at Emergency conditions	130	°C
Max. conductor operating temperature at Short circuit conditions	250	°C
Min. bending radius during installation in terms of cable outer diameter	12 \emptyset	

Constructional Data

Conductor		Insulation			Screen	Armour	Packing			Cable Code
Nominal area of conductor	Approx. conductor diameter	Thickness of insulation layers			Approx. metallic screen tape thickness	Tape thickness	Approx. overall diameter	Approx. overall weight	Standard cutting length $\pm 5\%$	
		C.S.	XLPE	I.S.						
mm ²	mm	Min.	Nom.	Min.	mm	mm	mm	kg / km	m	
35	6.90	0.3	5.5	0.3	0.076	0.50	54.7	3337	500	A317XK3BBGMRDXXI0MF
50	8.10	0.3	5.5	0.3	0.076	0.50	57.7	3712	500	A318XK3BBGMRDXXI0MF
70	9.70	0.3	5.5	0.3	0.076	0.50	61.4	4198	500	A319XK3BBGMRDXXI0MF
95	11.30	0.3	5.5	0.3	0.076	0.50	65.2	4750	500	A345XK3BBGMRDXXI0MF
120	12.60	0.3	5.5	0.3	0.076	0.50	68.4	5273	500	A346XK3BBGMRDXXI0MF
150	14.10	0.3	5.5	0.3	0.076	0.50	71.9	5810	500	A347XK3BBGMRDXXI0MF
185	15.80	0.3	5.5	0.3	0.076	0.50	76.2	6558	500	A348XK3BBGMRDXXI0MF
240	18.10	0.3	5.5	0.3	0.076	0.80	82.9	8360	500	A349XK3BBGMRDXXI0MF
300	20.50	0.3	5.5	0.3	0.076	0.80	88.5	9480	400	A350XK3BBGMRDXXI0MU
400	23.10	0.3	5.5	0.3	0.076	0.80	94.9	10958	350	A351XK3BBGMRDXXI0MV

Electrical Data

Nominal area of conductor	Electrical Characteristics					Continuous Current Ratings		
	Max. Conductor Resistance		Reactance (60 Hz)	Impedance (90 °C, 60 Hz)	Capacitance	Buried direct in the ground	In a buried duct	In air
	DC at 20 °C	AC at 90 °C				Fig. (a)	Fig. (b)	Fig. (c)
mm ²	Ω / km	Ω / km	Ω / km	Ω / km	$\mu F / km$	A	A	A
35	0.8680	1.1130	0.161	1.125	0.159	113	97	124
50	0.6410	0.8221	0.149	0.836	0.175	133	114	147
70	0.4430	0.5683	0.141	0.586	0.196	162	140	183
95	0.3200	0.4108	0.134	0.432	0.217	192	168	221
120	0.2530	0.3251	0.130	0.350	0.234	218	191	253
150	0.2060	0.2651	0.126	0.293	0.254	244	215	287
185	0.1640	0.2116	0.121	0.244	0.276	275	244	328
240	0.1250	0.1621	0.116	0.199	0.305	318	284	385
300	0.1000	0.1306	0.112	0.172	0.336	357	321	439
400	0.0778	0.1030	0.108	0.149	0.369	406	368	508

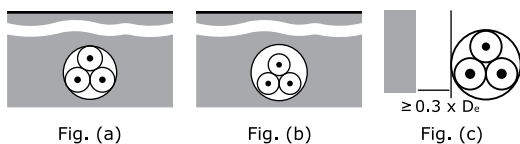

Laying Conditions: Ambient air temperature of 40 °C, Ambient ground temperature of 30 °C, Soil thermal resistivity of 1.5 K·m/W, Depth of laying of 0.8 m. and cable screens are bonded at both ends. In case of different laying conditions, appropriate correction (derating) factors from *Annex E* have to be applied to cater for the actual installation conditions.

Single-Core Cables, with Aluminum Conductors, XLPE Insulated, Wire Armoured and PVC Sheathed

APPLICATION

Suitable for installations indoors: mostly in power supply stations and outdoors: in cable ducts, underground, and on cable trays for industries, switch-boards and power stations. Due to the good laying and mechanical characteristics, this cable is suitable when mechanical protection is required or in applications where mechanical damages are expected to occur.

APPLICABLE STANDARDS

alfanar medium voltage cables are designed and tested to meet or exceed the requirements of IEC 60502-2 standard and/or BS 6622 standard with rated voltage 12.7 / 22 (24) kV. However, **alfanar** can also supply a range of alternative designs to meet customer-specified requirements.

CABLE CONSTRUCTION

Conductor

Stranded circular compacted aluminum conductor (Class 2).

Conductor Screen

Extruded layer of a cross-linkable semi-conducting compound as a stress control layer.

Insulation

Extruded layer of cross-linked polyethylene (XLPE).

Insulation Screen

Extruded layer of a cross-linkable semi-conducting compound firmly bonded to the insulation.

Metallic Screen

Flat plain copper tape helically applied over the insulation screen with suitable overlap.

Bedding

Extruded layer of Polyvinyl chloride (PVC).

Armouring

Single layer of round non-magnetic (aluminum) wires.

Outer Jacket

Extruded layer of Polyvinyl chloride (PVC).

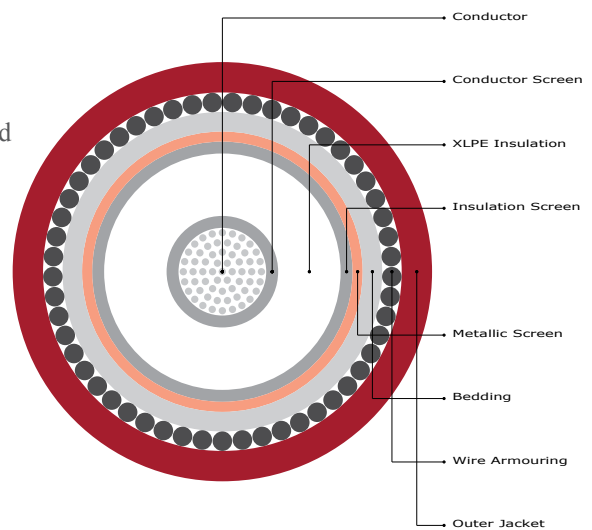

Note: The conductor screen, XLPE insulation and the insulation screen are extruded simultaneously in one process using triple extrusion method (Continuous Vulcanization Line). Triple extrusion method not only assures clean interfaces between the insulation and stress control layers, but also assures a construction free of Partial Discharge with high operational reliability.

TECHNICAL DATA

Rated voltage $U_0 / U (U_m)$	12 / 20 (24)	kV
Impulse test voltage (peak value)	125	kV
Power frequency test voltage for 5 minutes	42	kV
Max. conductor operating temperature at Normal conditions	90	°C
Max. conductor operating temperature at Emergency conditions	130	°C
Max. conductor operating temperature at Short circuit conditions	250	°C
Min. bending radius during installation in terms of cable outer diameter	15 Ø	

The above data is approximate and subject to manufacturing tolerance.

We reserve the right to change the above figures as a result of product development and/or changes in standard.

Constructional Data

Conductor		Insulation			Screen	Armour	Packing			Cable Code
Nominal area of conductor	Approx. conductor diameter	Thickness of insulation layers			Approx. metallic screen tape thickness	Wire diameter	Approx. overall diameter	Approx. overall weight	Standard cutting length $\pm 5\%$	
		C.S.	XLPE	I.S.						
mm ²	mm	Min.	Nom.	Min.	mm	mm	mm	kg / km	m	
35	6.90	0.3	5.5	0.3	0.076	1.60	30.1	1057	1000	A317XK1BBAMRDXXI0MR
50	8.10	0.3	5.5	0.3	0.076	1.60	31.5	1165	1000	A318XK1BBAMRDXXI0MR
70	9.70	0.3	5.5	0.3	0.076	2.00	34.1	1400	1000	A319XK1BBAMRDXXI0MR
95	11.30	0.3	5.5	0.3	0.076	2.00	35.7	1547	1000	A345XK1BBAMRDXXI0MR
120	12.60	0.3	5.5	0.3	0.076	2.00	37.2	1706	1000	A346XK1BBAMRDXXI0MR
150	14.10	0.3	5.5	0.3	0.076	2.00	38.7	1854	1000	A347XK1BBAMRDXXI0MR
185	15.80	0.3	5.5	0.3	0.076	2.00	40.6	2061	1000	A348XK1BBAMRDXXI0MR
240	18.10	0.3	5.5	0.3	0.076	2.00	42.9	2343	1000	A349XK1BBAMRDXXI0MR
300	20.50	0.3	5.5	0.3	0.076	2.50	46.9	2840	1000	A350XK1BBAMRDXXI0MR
400	23.10	0.3	5.5	0.3	0.076	2.50	49.7	3246	1000	A351XK1BBAMRDXXI0MR
500	26.50	0.3	5.5	0.3	0.076	2.50	53.5	3796	1000	A352XK1BBAMRDXXI0MR
630	30.05	0.3	5.5	0.3	0.076	2.50	57.5	4438	500	A353XK1BBAMRDXXI0MF
800	34.00	0.3	5.5	0.3	0.076	2.50	61.8	5245	500	A354XK1BBAMRDXXI0MF
1000	40.00	0.3	5.5	0.3	0.076	2.50	69.6	6378	500	A755XK1BBAMRDXXI0MF

Electrical Data

Nominal area of conductor	Electrical Characteristics					Continuous Current Ratings						
	Max. Conductor Resistance		Reactance (60 Hz)	Impedance (90 °C, 60 Hz)	Capacitance	Buried direct in the ground		In single-way ducts		In air		
	DC at 20 °C	AC at 90 °C				Trefoil	Flat spaced	Trefoil	Flat touched	Trefoil	Flat touched	Flat spaced
	mm ²	Ω / km	Ω / km	Ω / km	Ω / km	$\mu\text{F} / \text{km}$	A	A	A	A	A	A
35	0.8680	1.1130	0.188	1.129	0.159	118	121	109	108	139	142	163
50	0.6410	0.8220	0.176	0.841	0.175	139	142	128	127	166	169	194
70	0.4430	0.5683	0.168	0.593	0.196	169	171	156	153	207	210	240
95	0.3200	0.4107	0.160	0.441	0.217	200	200	185	180	250	252	288
120	0.2530	0.3249	0.155	0.360	0.234	225	221	208	200	288	288	326
150	0.2060	0.2648	0.149	0.304	0.254	251	242	230	220	326	324	364
185	0.1640	0.2112	0.143	0.255	0.276	281	266	257	244	372	368	409
240	0.1250	0.1616	0.137	0.212	0.305	321	296	291	272	435	424	467
300	0.1000	0.1299	0.135	0.187	0.336	357	320	322	297	495	477	520
400	0.0778	0.1020	0.129	0.165	0.369	394	344	351	320	562	530	577
500	0.0605	0.0806	0.125	0.148	0.413	437	372	386	347	640	593	643
630	0.0469	0.0641	0.121	0.137	0.459	479	399	421	374	721	656	709
800	0.0367	0.0522	0.117	0.128	0.511	518	425	453	399	800	715	775
1000	0.0291	0.0385	0.112	0.118	0.605	561	463	495	435	908	805	878

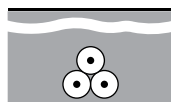

Fig. (a)

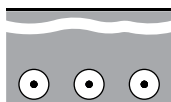

Fig. (b)

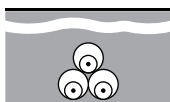

Fig. (c)

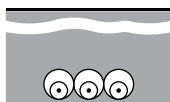

Fig. (d)

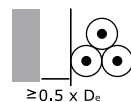

Fig. (e)



Fig. (f)

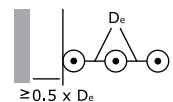

Fig. (g)

Laying Conditions: Ambient air temperature of 40 °C, Ambient ground temperature of 30 °C, Soil thermal resistivity of 1.5 K·m/W, Depth of laying of 0.8 m. and cable screens are bonded at both ends. In case of different laying conditions, appropriate correction (derating) factors from *Annex E* have to be applied to cater for the actual installation conditions.

Three-Core Cables, with Aluminum Conductors, XLPE Insulated, Wire Armoured and PVC Sheathed

APPLICATION

Suitable for installations indoors: mostly in power supply stations and outdoors: in cable ducts, underground, and on cable trays for industries, switch-boards and power stations. Due to the good laying and mechanical characteristics, this cable is suitable when mechanical protection is required or in applications where mechanical damages are expected to occur.

APPLICABLE STANDARDS

alfanar medium voltage cables are designed and tested to meet or exceed the requirements of IEC 60502-2 standard and/or BS 6622 standard with rated voltage 12.7 / 22 (24) kV. However, **alfanar** can also supply a range of alternative designs to meet customer-specified requirements.

CABLE CONSTRUCTION

Conductor

Stranded circular compacted aluminum conductor (Class 2).

Conductor Screen

Extruded layer of a cross-linkable semi-conducting compound as a stress control layer.

Insulation

Extruded layer of cross-linked polyethylene (XLPE).

Insulation Screen

Extruded layer of a cross-linkable semi-conducting compound firmly bonded to the insulation.

Metallic Screen

Flat plain copper tape helically applied over the insulation screen with suitable overlap.

Filler

Non-hygroscopic polypropylene filler suitable for the cable's operating temperature.

Bedding

Extruded layer of Polyvinyl chloride (PVC).

Armouring

Single layer of round galvanized steel wires.

Outer Jacket

Extruded layer of Polyvinyl chloride (PVC).

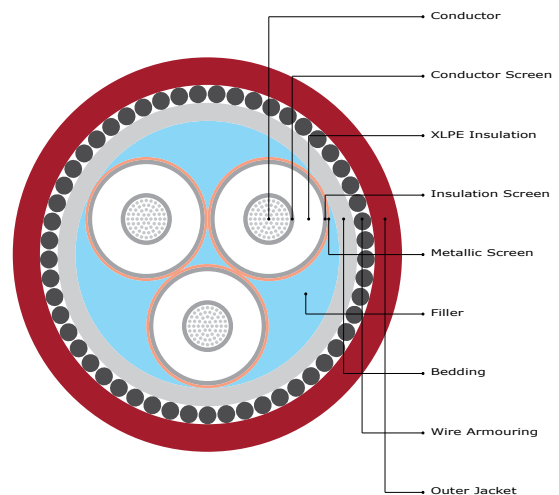

Note: The conductor screen, XLPE insulation and the insulation screen are extruded simultaneously in one process using triple extrusion method (Continuous Vulcanization Line). Triple extrusion method not only assures clean interfaces between the insulation and stress control layers, but also assures a construction free of Partial Discharge with high operational reliability.

TECHNICAL DATA

Rated voltage $U_0 / U (U_m)$	12 / 20 (24)	kV
Impulse test voltage (peak value)	125	kV
Power frequency test voltage for 5 minutes	42	kV
Max. conductor operating temperature at Normal conditions	90	°C
Max. conductor operating temperature at Emergency conditions	130	°C
Max. conductor operating temperature at Short circuit conditions	250	°C
Min. bending radius during installation in terms of cable outer diameter	12 \emptyset	

Constructional Data

Conductor		Insulation			Screen	Armour	Packing			Cable Code
Nominal area of conductor	Approx. conductor diameter	Thickness of insulation layers			Approx. metallic screen tape thickness	Wire diameter	Approx. overall diameter	Approx. overall weight	Standard cutting length $\pm 5\%$	
		C.S.	XLPE	I.S.						
mm ²	mm	Min.	Nom.	Min.	mm	mm	mm	kg / km	m	
35	6.90	0.3	5.5	0.3	0.076	2.50	57.9	5006	500	A317XK3BBWMDXXI0MF
50	8.10	0.3	5.5	0.3	0.076	2.50	60.9	5467	500	A318XK3BBWMDXXI0MF
70	9.70	0.3	5.5	0.3	0.076	2.50	64.6	6069	500	A319XK3BBWMDXXI0MF
95	11.30	0.3	5.5	0.3	0.076	2.50	68.4	6736	500	A345XK3BBWMDXXI0MF
120	12.60	0.3	5.5	0.3	0.076	3.15	73.7	8369	500	A346XK3BBWMDXXI0MF
150	14.10	0.3	5.5	0.3	0.076	3.15	77.2	9064	500	A347XK3BBWMDXXI0MF
185	15.80	0.3	5.5	0.3	0.076	3.15	81.3	9927	500	A348XK3BBWMDXXI0MF
240	18.10	0.3	5.5	0.3	0.076	3.15	86.8	11233	400	A349XK3BBWMDXXI0MU
300	20.50	0.3	5.5	0.3	0.076	3.15	92.4	12559	350	A350XK3BBWMDXXI0MV
400	23.10	0.3	5.5	0.3	0.076	3.15	98.8	14239	300	A351XK3BBWMDXXI0MT

Electrical Data

Nominal area of conductor	Electrical Characteristics					Continuous Current Ratings		
	Max. Conductor Resistance		Reactance (60 Hz)	Impedance (90 °C, 60 Hz)	Capacitance	Buried direct in the ground	In a buried duct	In air
	DC at 20 °C	AC at 90 °C				Fig. (a)	Fig. (b)	Fig. (c)
mm ²	Ω / km	Ω / km	Ω / km	Ω / km	$\mu\text{F} / \text{km}$	A	A	A
35	0.8680	1.1130	0.161	1.125	0.159	114	98	126
50	0.6410	0.8221	0.149	0.836	0.175	133	116	150
70	0.4430	0.5683	0.141	0.586	0.196	162	142	185
95	0.3200	0.4108	0.134	0.432	0.217	193	169	224
120	0.2530	0.3251	0.130	0.350	0.234	217	192	256
150	0.2060	0.2651	0.126	0.293	0.254	243	215	289
185	0.1640	0.2116	0.121	0.244	0.276	273	243	329
240	0.1250	0.1621	0.116	0.199	0.305	312	280	384
300	0.1000	0.1306	0.112	0.172	0.336	348	314	434
400	0.0778	0.1030	0.108	0.149	0.369	390	354	495

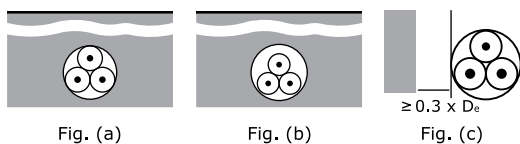

Laying Conditions: Ambient air temperature of 40 °C, Ambient ground temperature of 30 °C, Soil thermal resistivity of 1.5 K·m/W, Depth of laying of 0.8 m. and cable screens are bonded at both ends. In case of different laying conditions, appropriate correction (derating) factors from *Annex E* have to be applied to cater for the actual installation conditions.

Single-Core Cables, with Copper Conductors, XLPE Insulated and PVC Sheathed

APPLICATION

Suitable for installations indoors: mostly in power supply stations and outdoors: in cable ducts, underground, and on cable trays for industries, switch-boards and power stations.

APPLICABLE STANDARDS

alfanar medium voltage cables are designed and tested to meet or exceed the requirements of IEC 60502-2 standard. However, **alfanar** can also supply a range of alternative designs to meet customer-specified requirements.

CABLE CONSTRUCTION

Conductor

Plain annealed stranded circular compacted copper conductor (Class 2).

Conductor Screen

Extruded layer of a cross-linkable semi-conducting compound as a stress control layer.

Insulation

Extruded layer of cross-linked polyethylene (XLPE).

Insulation Screen

Extruded layer of a cross-linkable semi-conducting compound firmly bonded to the insulation.

Metallic Screen

Flat plain copper tape helically applied over the insulation screen with suitable overlap.

Outer Jacket

Extruded layer of Polyvinyl chloride (PVC).

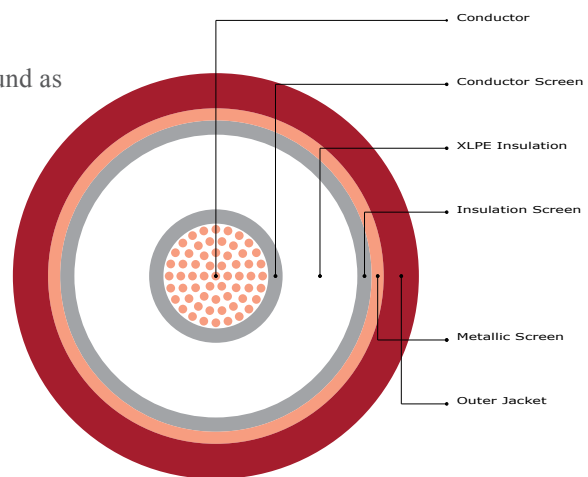

Note: The conductor screen, XLPE insulation and the insulation screen are extruded simultaneously in one process using triple extrusion method (Continuous Vulcanization Line). Triple extrusion method not only assures clean interfaces between the insulation and stress control layers, but also assures a construction free of Partial Discharge with high operational reliability.

TECHNICAL DATA

Rated voltage $U_0 / U (U_m)$	18 / 30 (36)	kV
Impulse test voltage (peak value)	170	kV
Power frequency test voltage for 5 minutes	63	kV
Max. conductor operating temperature at Normal conditions	90	°C
Max. conductor operating temperature at Emergency conditions	130	°C
Max. conductor operating temperature at Short circuit conditions	250	°C
Min. bending radius during installation in terms of cable outer diameter	20 Ø	

The above data is approximate and subject to manufacturing tolerance.

We reserve the right to change the above figures as a result of product development and/or changes in standard.

Constructional Data

Conductor		Insulation			Screen	Armour	Packing			Cable Code
Nominal area of conductor	Approx. conductor diameter	Thickness of insulation layers			Approx. metallic screen tape thickness	N / A	Approx. overall diameter	Approx. overall weight	Standard cutting length $\pm 5\%$	
		C.S	XLPE	I.S						
mm ²	mm	Min.	Nom.	Min.	mm	mm	mm	kg / km	m	
50	8.10	0.3	8.0	0.3	0.076	-	30.4	1234	1000	C318XM1BB0MRDXXI0MR
70	9.70	0.3	8.0	0.3	0.076	-	32.0	1479	1000	C319XM1BB0MRDXXI0MR
95	11.30	0.3	8.0	0.3	0.076	-	33.8	1783	1000	C345XM1BB0MRDXXI0MR
120	12.60	0.3	8.0	0.3	0.076	-	35.1	2063	1000	C346XM1BB0MRDXXI0MR
150	14.10	0.3	8.0	0.3	0.076	-	36.8	2367	1000	C347XM1BB0MRDXXI0MR
185	15.80	0.3	8.0	0.3	0.076	-	38.5	2782	1000	C348XM1BB0MRDXXI0MR
240	18.10	0.3	8.0	0.3	0.076	-	41.0	3397	1000	C349XM1BB0MRDXXI0MR
300	20.50	0.3	8.0	0.3	0.076	-	43.6	4061	1000	C350XM1BB0MRDXXI0MR
400	23.10	0.3	8.0	0.3	0.076	-	46.4	4953	1000	C351XM1BB0MRDXXI0MR
500	26.50	0.3	8.0	0.3	0.076	-	50.0	6162	500	C352XM1BB0MRDXXI0MF
630	30.05	0.3	8.0	0.3	0.076	-	53.8	7526	500	C353XM1BB0MRDXXI0MF
800	34.00	0.3	8.0	0.3	0.076	-	58.1	9422	500	C354XM1BB0MRDXXI0MF
1000	40.00	0.3	8.0	0.3	0.076	-	65.7	11742	500	C755XM1BB0MRDXXI0MF

Electrical Data

Nominal area of conductor	Electrical Characteristics					Continuous Current Ratings						
	Max. Conductor Resistance		Reactance (60 Hz)	Impedance (90 °C, 60 Hz)	Capacitance	Buried direct in the ground		In single-way ducts		In air		
	DC at 20 °C	AC at 90 °C				Trefoil	Flat spaced	Trefoil	Flat touched	Trefoil	Flat touched	Flat spaced
	mm ²	Ω / km	Ω / km	Ω / km	Ω / km	$\mu\text{F} / \text{km}$	A	A	A	A	A	A
50	0.3870	0.4938	0.173	0.523	0.137	178	185	162	162	204	209	249
70	0.2680	0.3422	0.163	0.379	0.152	217	226	198	198	255	262	311
95	0.1930	0.2468	0.156	0.292	0.167	259	269	238	237	311	319	380
120	0.1530	0.1960	0.150	0.247	0.179	293	304	270	269	359	368	436
150	0.1240	0.1593	0.145	0.216	0.192	327	340	303	301	409	419	497
185	0.0991	0.1280	0.139	0.189	0.208	368	382	343	340	470	481	569
240	0.0754	0.0984	0.134	0.166	0.228	425	439	397	393	556	568	669
300	0.0601	0.0795	0.129	0.152	0.250	476	491	448	441	638	651	767
400	0.0470	0.0638	0.124	0.140	0.273	535	550	508	497	735	747	878
500	0.0366	0.0517	0.120	0.130	0.303	599	612	573	557	846	856	1007
630	0.0283	0.0424	0.116	0.123	0.335	664	675	643	618	963	969	1140
800	0.0221	0.0358	0.112	0.118	0.371	725	733	709	676	1081	1080	1271
1000	0.0176	0.0245	0.107	0.110	0.436	891	829	842	782	1387	1359	1503

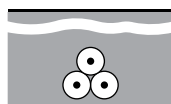

Fig. (a)

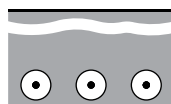

Fig. (b)

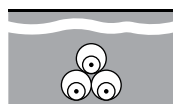

Fig. (c)

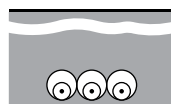

Fig. (d)

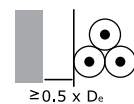

Fig. (e)



Fig. (f)

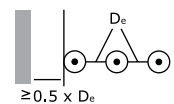

Fig. (g)

Laying Conditions: Ambient air temperature of 40 °C, Ambient ground temperature of 30 °C, Soil thermal resistivity of 1.5 K·m/W, Depth of laying of 0.8 m, and cable screens are bonded at both ends. In case of different laying conditions, appropriate correction (derating) factors from *Annex E* have to be applied to cater for the actual installation conditions.

Three-Core Cables, with Copper Conductors, XLPE Insulated and PVC Sheathed

APPLICATION

Suitable for installations indoors: mostly in power supply stations and outdoors: in cable ducts, underground, and on cable trays for industries, switch-boards and power stations.

APPLICABLE STANDARDS

alfanar medium voltage cables are designed and tested to meet or exceed the requirements of IEC 60502-2 standard. However, **alfanar** can also supply a range of alternative designs to meet customer-specified requirements.

CABLE CONSTRUCTION

Conductor

Plain annealed stranded circular compacted copper conductor (Class 2).

Conductor Screen

Extruded layer of a cross-linkable semi-conducting compound as a stress control layer.

Insulation

Extruded layer of cross-linked polyethylene (XLPE).

Insulation Screen

Extruded layer of a cross-linkable semi-conducting compound firmly bonded to the insulation.

Metallic Screen

Flat plain copper tape helically applied over the insulation screen with suitable overlap.

Filler

Non-hygroscopic polypropylene filler suitable for the cable's operating temperature.

Outer Jacket

Extruded layer of Polyvinyl chloride (PVC).

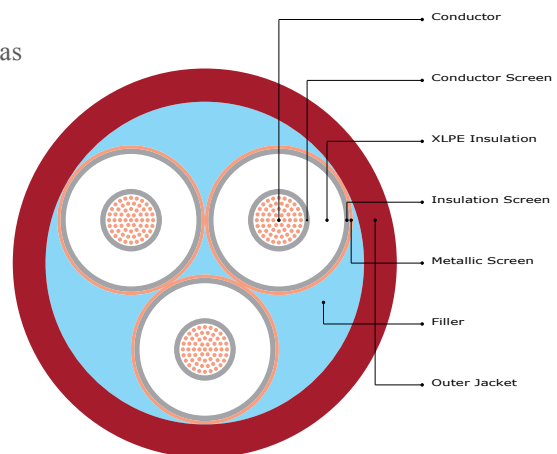

Note: The conductor screen, XLPE insulation and the insulation screen are extruded simultaneously in one process using triple extrusion method (Continuous Vulcanization Line). Triple extrusion method not only assures clean interfaces between the insulation and stress control layers, but also assures a construction free of Partial Discharge with high operational reliability.

TECHNICAL DATA

Rated voltage $U_0 / U (U_m)$	18 / 30 (36)	kV
Impulse test voltage (peak value)	170	kV
Power frequency test voltage for 5 minutes	63	kV
Max. conductor operating temperature at Normal conditions	90	°C
Max. conductor operating temperature at Emergency conditions	130	°C
Max. conductor operating temperature at Short circuit conditions	250	°C
Min. bending radius during installation in terms of cable outer diameter	15 Ø	

The above data is approximate and subject to manufacturing tolerance.

We reserve the right to change the above figures as a result of product development and/or changes in standard.

Constructional Data

Conductor		Insulation			Screen	Armour	Packing			Cable Code
Nominal area of conductor	Approx. conductor diameter	Thickness of insulation layers			Approx. metallic screen tape thickness	N / A	Approx. overall diameter	Approx. overall weight	Standard cutting length $\pm 5\%$	
		C.S.	XLPE	I.S.						
mm ²	mm	Min.	Nom.	Min.	mm	mm	mm	kg / km	m	
50	8.10	0.3	8.0	0.3	0.076	-	63.7	4225	500	C318XM3BB0MRDXXI0MF
70	9.70	0.3	8.0	0.3	0.076	-	67.4	5054	500	C319XM3BB0MRDXXI0MF
95	11.30	0.3	8.0	0.3	0.076	-	71.0	6013	500	C345XM3BB0MRDXXI0MF
120	12.60	0.3	8.0	0.3	0.076	-	74.0	6941	500	C346XM3BB0MRDXXI0MF
150	14.10	0.3	8.0	0.3	0.076	-	77.5	7907	500	C347XM3BB0MRDXXI0MF
185	15.80	0.3	8.0	0.3	0.076	-	81.4	9274	500	C348XM3BB0MRDXXI0MF
240	18.10	0.3	8.0	0.3	0.076	-	86.7	11253	400	C349XM3BB0MRDXXI0MU
300	20.50	0.3	8.0	0.3	0.076	-	92.1	13358	400	C350XM3BB0MRDXXI0MU
400	23.10	0.3	8.0	0.3	0.076	-	98.3	16252	350	C351XM3BB0MRDXXI0MV

Electrical Data

Nominal area of conductor	Electrical Characteristics					Continuous Current Ratings		
	Max. Conductor Resistance		Reactance (60 Hz)	Impedance (90 °C, 60 Hz)	Capacitance	Buried direct in the ground	In a buried duct	In air
	DC at 20 °C	AC at 90 °C				Fig. (a)	Fig. (b)	Fig. (c)
mm ²	Ω / km	Ω / km	Ω / km	Ω / km	$\mu\text{F} / \text{km}$	A	A	A
50	0.3870	0.4938	0.165	0.521	0.137	179	151	204
70	0.2680	0.3423	0.156	0.376	0.152	218	185	254
95	0.1930	0.2469	0.149	0.288	0.167	260	222	309
120	0.1530	0.1961	0.144	0.243	0.179	294	253	355
150	0.1240	0.1595	0.139	0.211	0.192	329	284	403
185	0.0991	0.1282	0.133	0.185	0.208	371	322	462
240	0.0754	0.0986	0.127	0.161	0.228	426	374	542
300	0.0601	0.0799	0.123	0.146	0.250	478	422	619
400	0.0470	0.0643	0.118	0.134	0.273	536	477	708

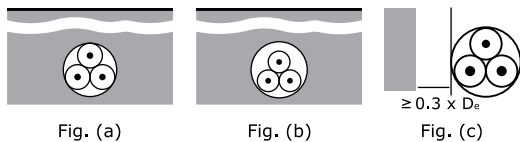

Laying Conditions: Ambient air temperature of 40 °C, Ambient ground temperature of 30 °C, Soil thermal resistivity of 1.5 K·m/W, Depth of laying of 0.8 m, and cable screens are bonded at both ends. In case of different laying conditions, appropriate correction (derating) factors from *Annex E* have to be applied to cater for the actual installation conditions.

Single-Core Cables, with Copper Conductors, XLPE Insulated, Tape Armoured and PVC Sheathed

APPLICATION

Suitable for installations indoors: mostly in power supply stations and outdoors: in cable ducts, underground, and on cable trays for industries, switch-boards and power stations. Due to the good laying and mechanical characteristics, this cable is suitable when mechanical protection is required or in applications where mechanical damages are expected to occur.

APPLICABLE STANDARDS

alfanar medium voltage cables are designed and tested to meet or exceed the requirements of IEC 60502-2 standard. However, **alfanar** can also supply a range of alternative designs to meet customer-specified requirements.

CABLE CONSTRUCTION

Conductor

Plain annealed stranded circular compacted copper conductor (Class 2).

Conductor Screen

Extruded layer of a cross-linkable semi-conducting compound as a stress control layer.

Insulation

Extruded layer of cross-linked polyethylene (XLPE).

Insulation Screen

Extruded layer of a cross-linkable semi-conducting compound firmly bonded to the insulation.

Metallic Screen

Flat plain copper tape helically applied over the insulation screen with suitable overlap.

Bedding

Extruded layer of Polyvinyl chloride (PVC).

Armouring

Double layer of non-magnetic (aluminum) tapes.

Outer Jacket

Extruded layer of Polyvinyl chloride (PVC).

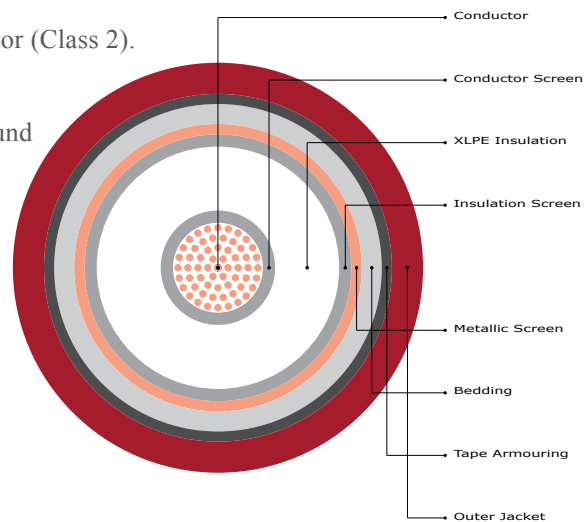

Note: The conductor screen, XLPE insulation and the insulation screen are extruded simultaneously in one process using triple extrusion method (Continuous Vulcanization Line). Triple extrusion method not only assures clean interfaces between the insulation and stress control layers, but also assures a construction free of Partial Discharge with high operational reliability.

TECHNICAL DATA

Rated voltage $U_0 / U (U_m)$	18 / 30 (36)	kV
Impulse test voltage (peak value)	170	kV
Power frequency test voltage for 5 minutes	63	kV
Max. conductor operating temperature at Normal conditions	90	°C
Max. conductor operating temperature at Emergency conditions	130	°C
Max. conductor operating temperature at Short circuit conditions	250	°C
Min. bending radius during installation in terms of cable outer diameter	15 Ø	

The above data is approximate and subject to manufacturing tolerance.

We reserve the right to change the above figures as a result of product development and/or changes in standard.

Constructional Data

Conductor		Insulation			Screen	Armour	Packing			Cable Code
Nominal area of conductor	Approx. conductor diameter	Thickness of insulation layers			Approx. metallic screen tape thickness	Tape thickness	Approx. overall diameter	Approx. overall weight	Standard cutting length $\pm 5\%$	
		C.S.	XLPE	I.S.						
mm ²	mm	Min.	Nom.	Min.	mm	mm	mm	kg / km	m	
50	8.10	0.3	8.0	0.3	0.076	0.50	35.0	1630	1000	C318XM1BBBMRDXXI0MR
70	9.70	0.3	8.0	0.3	0.076	0.50	36.8	1913	1000	C319XM1BBBMRDXXI0MR
95	11.30	0.3	8.0	0.3	0.076	0.50	38.4	2221	1000	C345XM1BBBMRDXXI0MR
120	12.60	0.3	8.0	0.3	0.076	0.50	39.9	2536	1000	C346XM1BBBMRDXXI0MR
150	14.10	0.3	8.0	0.3	0.076	0.50	41.6	2861	1000	C347XM1BBBMRDXXI0MR
185	15.80	0.3	8.0	0.3	0.076	0.50	43.5	3320	1000	C348XM1BBBMRDXXI0MR
240	18.10	0.3	8.0	0.3	0.076	0.50	46.0	3968	1000	C349XM1BBBMRDXXI0MR
300	20.50	0.3	8.0	0.3	0.076	0.50	48.6	4665	1000	C350XM1BBBMRDXXI0MR
400	23.10	0.3	8.0	0.3	0.076	0.50	51.4	5594	1000	C351XM1BBBMRDXXI0MR
500	26.50	0.3	8.0	0.3	0.076	0.50	55.2	6878	500	C352XM1BBBMRDXXI0MF
630	30.05	0.3	8.0	0.3	0.076	0.50	59.4	8352	500	C353XM1BBBMRDXXI0MF
800	34.00	0.3	8.0	0.3	0.076	0.50	63.7	10311	500	C354XM1BBBMRDXXI0MF
1000	40.00	0.3	8.0	0.3	0.076	0.50	71.5	12778	500	C755XM1BBBMRDXXI0MF

Electrical Data

Nominal area of conductor	Electrical Characteristics					Continuous Current Ratings						
	Max. Conductor Resistance		Reactance (60 Hz)	Impedance (90 °C, 60 Hz)	Capacitance	Buried direct in the ground		In single-way ducts		In air		
	DC at 20 °C	AC at 90 °C				Trefoil	Flat spaced	Trefoil	Flat touched	Trefoil	Flat touched	Flat spaced
	mm ²	Ω / km	Ω / km	Ω / km	Ω / km	$\mu\text{F} / \text{km}$	Fig. (a)	Fig. (b)	Fig. (c)	Fig. (d)	Fig. (e)	Fig. (f)
50	0.3870	0.4938	0.183	0.527	0.137	178	184	164	163	209	214	248
70	0.2680	0.3422	0.174	0.384	0.152	217	224	200	199	261	266	308
95	0.1930	0.2468	0.165	0.297	0.167	258	265	239	237	317	323	373
120	0.1530	0.1960	0.160	0.253	0.179	291	298	271	267	364	370	426
150	0.1240	0.1592	0.155	0.222	0.192	326	331	303	298	414	420	482
185	0.0991	0.1278	0.149	0.196	0.208	366	369	341	334	474	480	548
240	0.0754	0.0982	0.142	0.173	0.228	421	419	393	381	558	562	639
300	0.0601	0.0793	0.137	0.158	0.250	473	464	441	425	639	640	723
400	0.0470	0.0634	0.132	0.146	0.273	530	513	496	473	733	730	817
500	0.0366	0.0512	0.127	0.137	0.303	592	564	556	524	841	830	924
630	0.0283	0.0418	0.123	0.130	0.335	652	597	610	562	949	921	1006
800	0.0221	0.0352	0.119	0.124	0.371	705	622	657	591	1054	1005	1080
1000	0.0176	0.0243	0.114	0.116	0.436	831	662	743	643	1296	1188	1201

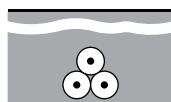

Fig. (a)

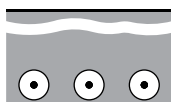

Fig. (b)

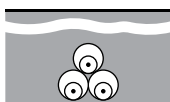

Fig. (c)

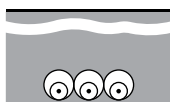

Fig. (d)

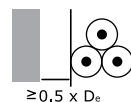

Fig. (e)



Fig. (f)

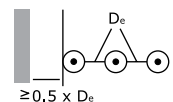

Fig. (g)

Laying Conditions: Ambient air temperature of 40 °C, Ambient ground temperature of 30 °C, Soil thermal resistivity of 1.5 K·m/W, Depth of laying of 0.8 m, and cable screens are bonded at both ends. In case of different laying conditions, appropriate correction (derating) factors from *Annex E* have to be applied to cater for the actual installation conditions.

Three-Core Cables, with Copper Conductors, XLPE Insulated, Tape Armoured and PVC Sheathed

APPLICATION

Suitable for installations indoors: mostly in power supply stations and outdoors: in cable ducts, underground, and on cable trays for industries, switch-boards and power stations. Due to the good laying and mechanical characteristics, this cable is suitable when mechanical protection is required or in applications where mechanical damages are expected to occur.

APPLICABLE STANDARDS

alfanar medium voltage cables are designed and tested to meet or exceed the requirements of IEC 60502-2 standard. However, **alfanar** can also supply a range of alternative designs to meet customer-specified requirements.

CABLE CONSTRUCTION

Conductor

Plain annealed stranded circular compacted copper conductor (Class 2).

Conductor Screen

Extruded layer of a cross-linkable semi-conducting compound as a stress control layer.

Insulation

Extruded layer of cross-linked polyethylene (XLPE).

Insulation Screen

Extruded layer of a cross-linkable semi-conducting compound firmly bonded to the insulation.

Metallic Screen

Flat plain copper tape helically applied over the insulation screen with suitable overlap.

Filler

Non-hygroscopic polypropylene filler suitable for the cable's operating temperature.

Bedding

Extruded layer of Polyvinyl chloride (PVC).

Armouring

Double layer of galvanized steel tapes.

Outer Jacket

Extruded layer of Polyvinyl chloride (PVC).

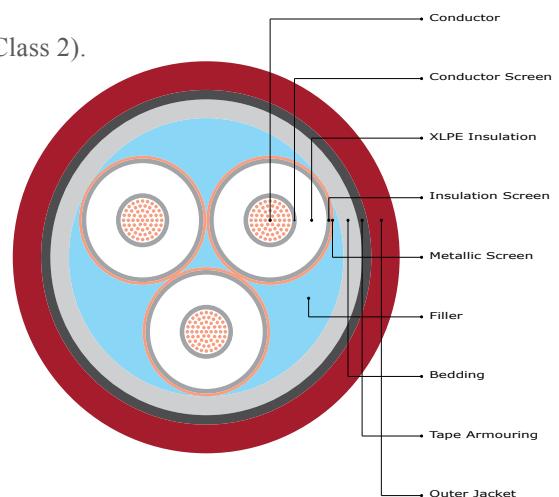

Note: The conductor screen, XLPE insulation and the insulation screen are extruded simultaneously in one process using triple extrusion method (Continuous Vulcanization Line). Triple extrusion method not only assures clean interfaces between the insulation and stress control layers, but also assures a construction free of Partial Discharge with high operational reliability.

TECHNICAL DATA

Rated voltage $U_0 / U (U_m)$	18 / 30 (36)	kV
Impulse test voltage (peak value)	170	kV
Power frequency test voltage for 5 minutes	63	kV
Max. conductor operating temperature at Normal conditions	90	°C
Max. conductor operating temperature at Emergency conditions	130	°C
Max. conductor operating temperature at Short circuit conditions	250	°C
Min. bending radius during installation in terms of cable outer diameter	12 \emptyset	

Constructional Data

Conductor		Insulation			Screen	Armour	Packing			Cable Code
Nominal area of conductor	Approx. conductor diameter	Thickness of insulation layers			Approx. metallic screen tape thickness	Tape thickness	Approx. overall diameter	Approx. overall weight	Standard cutting length $\pm 5\%$	
		C.S.	XLPE	I.S.						
mm ²	mm	Min.	Nom.	Min.	mm	mm	mm	kg / km	m	
50	8.10	0.3	8.0	0.3	0.076	0.50	69.7	5932	500	C318XM3BBGMRDXXI0MF
70	9.70	0.3	8.0	0.3	0.076	0.50	73.4	6856	500	C319XM3BBGMRDXXI0MF
95	11.30	0.3	8.0	0.3	0.076	0.50	77.2	7949	500	C345XM3BBGMRDXXI0MF
120	12.60	0.3	8.0	0.3	0.076	0.80	81.8	9790	500	C346XM3BBGMRDXXI0MF
150	14.10	0.3	8.0	0.3	0.076	0.80	85.3	10884	500	C347XM3BBGMRDXXI0MF
185	15.80	0.3	8.0	0.3	0.076	0.80	89.4	12443	400	C348XM3BBGMRDXXI0MU
240	18.10	0.3	8.0	0.3	0.076	0.80	94.9	14668	400	C349XM3BBGMRDXXI0MU
300	20.50	0.3	8.0	0.3	0.076	0.80	100.5	17031	350	C350XM3BBGMRDXXI0MV
400	23.10	0.3	8.0	0.3	0.076	0.80	106.9	20214	300	C351XM3BBGMRDXXI0MT

Electrical Data

Nominal area of conductor	Electrical Characteristics					Continuous Current Ratings		
	Max. Conductor Resistance		Reactance (60 Hz)	Impedance (90 °C, 60 Hz)	Capacitance	Buried direct in the ground	In a buried duct	In air
	DC at 20 °C	AC at 90 °C				Fig. (a)	Fig. (b)	Fig. (c)
mm ²	Ω / km	Ω / km	Ω / km	Ω / km	$\mu F / km$	A	A	A
50	0.3870	0.4938	0.165	0.521	0.137	171	147	190
70	0.2680	0.3423	0.156	0.376	0.152	208	180	235
95	0.1930	0.2469	0.149	0.288	0.167	248	216	285
120	0.1530	0.1961	0.144	0.243	0.179	280	245	325
150	0.1240	0.1595	0.139	0.211	0.192	313	276	369
185	0.0991	0.1282	0.133	0.185	0.208	352	312	419
240	0.0754	0.0986	0.127	0.161	0.228	404	360	489
300	0.0601	0.0799	0.123	0.146	0.250	451	405	555
400	0.0470	0.0643	0.118	0.134	0.273	506	458	633

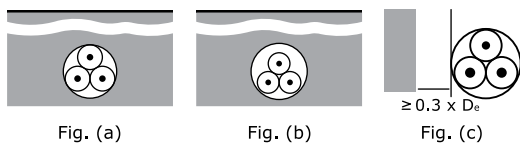

Laying Conditions: Ambient air temperature of 40 °C, Ambient ground temperature of 30 °C, Soil thermal resistivity of 1.5 K·m/W, Depth of laying of 0.8 m. and cable screens are bonded at both ends. In case of different laying conditions, appropriate correction (derating) factors from *Annex E* have to be applied to cater for the actual installation conditions.

Single-Core Cables, with Copper Conductors, XLPE Insulated, Wire Armoured and PVC Sheathed

APPLICATION

Suitable for installations indoors: mostly in power supply stations and outdoors: in cable ducts, underground, and on cable trays for industries, switch-boards and power stations. Due to the good laying and mechanical characteristics, this cable is suitable when mechanical protection is required or in applications where mechanical damages are expected to occur.

APPLICABLE STANDARDS

alfanar medium voltage cables are designed and tested to meet or exceed the requirements of IEC 60502-2 standard and/or BS 6622 standard with rated voltage 19 / 33 (36) kV. However, **alfanar** can also supply a range of alternative designs to meet customer-specified requirements.

CABLE CONSTRUCTION

Conductor

Plain annealed stranded circular compacted copper conductor (Class 2).

Conductor Screen

Extruded layer of a cross-linkable semi-conducting compound as a stress control layer.

Insulation

Extruded layer of cross-linked polyethylene (XLPE).

Insulation Screen

Extruded layer of a cross-linkable semi-conducting compound firmly bonded to the insulation.

Metallic Screen

Flat plain copper tape helically applied over the insulation screen with suitable overlap.

Bedding

Extruded layer of Polyvinyl chloride (PVC).

Armouring

Single layer of round non-magnetic (aluminum) wires.

Outer Jacket

Extruded layer of Polyvinyl chloride (PVC).

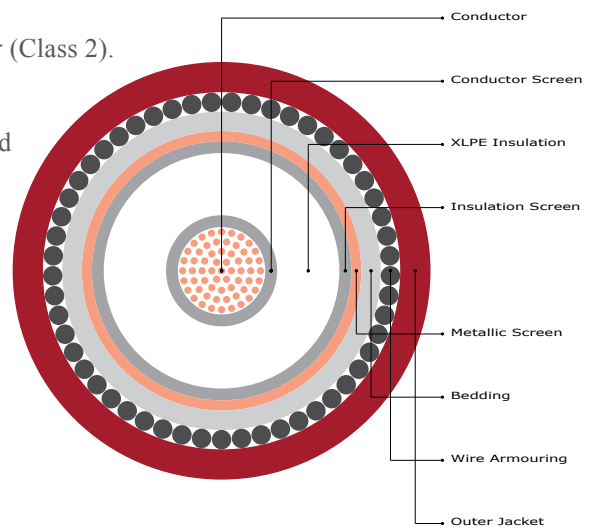

Note: The conductor screen, XLPE insulation and the insulation screen are extruded simultaneously in one process using triple extrusion method (Continuous Vulcanization Line). Triple extrusion method not only assures clean interfaces between the insulation and stress control layers, but also assures a construction free of Partial Discharge with high operational reliability.

TECHNICAL DATA

Rated voltage $U_0 / U (U_m)$	18 / 30 (36)	kV
Impulse test voltage (peak value)	170	kV
Power frequency test voltage for 5 minutes	63	kV
Max. conductor operating temperature at Normal conditions	90	°C
Max. conductor operating temperature at Emergency conditions	130	°C
Max. conductor operating temperature at Short circuit conditions	250	°C
Min. bending radius during installation in terms of cable outer diameter	15 Ø	

The above data is approximate and subject to manufacturing tolerance.

We reserve the right to change the above figures as a result of product development and/or changes in standard.

Constructional Data

Conductor		Insulation			Screen	Armour	Packing			Cable Code
Nominal area of conductor	Approx. conductor diameter	Thickness of insulation layers			Approx. metallic screen tape thickness	Wire diameter	Approx. overall diameter	Approx. overall weight	Standard cutting length $\pm 5\%$	
		C.S	XLPE	I.S						
mm ²	mm	Min.	Nom.	Min.	mm	mm	mm	kg / km	m	
50	8.10	0.3	8.0	0.3	0.076	2.00	37.7	1911	1000	C318XM1BBAMRDXXI0MR
70	9.70	0.3	8.0	0.3	0.076	2.00	39.3	2185	1000	C319XM1BBAMRDXXI0MR
95	11.30	0.3	8.0	0.3	0.076	2.00	41.1	2523	1000	C345XM1BBAMRDXXI0MR
120	12.60	0.3	8.0	0.3	0.076	2.00	42.4	2829	1000	C346XM1BBAMRDXXI0MR
150	14.10	0.3	8.0	0.3	0.076	2.50	45.3	3321	1000	C347XM1BBAMRDXXI0MR
185	15.80	0.3	8.0	0.3	0.076	2.50	47.2	3802	1000	C348XM1BBAMRDXXI0MR
240	18.10	0.3	8.0	0.3	0.076	2.50	49.7	4483	1000	C349XM1BBAMRDXXI0MR
300	20.50	0.3	8.0	0.3	0.076	2.50	52.3	5210	1000	C350XM1BBAMRDXXI0MR
400	23.10	0.3	8.0	0.3	0.076	2.50	55.1	6170	1000	C351XM1BBAMRDXXI0MR
500	26.50	0.3	8.0	0.3	0.076	2.50	58.9	7494	500	C352XM1BBAMRDXXI0MF
630	30.05	0.3	8.0	0.3	0.076	2.50	63.1	9010	500	C353XM1BBAMRDXXI0MF
800	34.00	0.3	8.0	0.3	0.076	2.50	67.4	11021	500	C354XM1BBAMRDXXI0MF
1000	40.00	0.3	8.0	0.3	0.076	2.50	75.2	13566	500	C755XM1BBAMRDXXI0MF

Electrical Data

Nominal area of conductor	Electrical Characteristics					Continuous Current Ratings						
	Max. Conductor Resistance		Reactance (60 Hz)	Impedance (90 °C, 60 Hz)	Capacitance	Buried direct in the ground		In single-way ducts		In air		
	DC at 20 °C	AC at 90 °C				Trefoil	Flat spaced	Trefoil	Flat touched	Trefoil	Flat touched	Flat spaced
	mm ²	Ω / km	Ω / km	Ω / km	Ω / km	$\mu\text{F} / \text{km}$	A	A	A	A	A	A
50	0.3870	0.4938	0.189	0.529	0.137	178	180	164	161	214	217	247
70	0.2680	0.3422	0.179	0.386	0.152	216	214	198	193	265	267	303
95	0.1930	0.2467	0.171	0.300	0.167	256	249	234	225	320	320	361
120	0.1530	0.1959	0.165	0.256	0.179	286	270	260	246	366	361	402
150	0.1240	0.1592	0.161	0.227	0.192	317	292	286	268	413	403	446
185	0.0991	0.1277	0.155	0.201	0.208	353	317	316	293	469	453	495
240	0.0754	0.0980	0.148	0.178	0.228	399	346	353	321	542	514	555
300	0.0601	0.0791	0.143	0.163	0.250	439	369	385	345	611	571	608
400	0.0470	0.0632	0.137	0.151	0.273	473	388	410	362	679	618	661
500	0.0366	0.0509	0.132	0.141	0.303	513	411	442	386	757	676	722
630	0.0283	0.0415	0.128	0.134	0.335	551	434	472	409	835	733	782
800	0.0221	0.0348	0.123	0.128	0.371	583	456	499	429	907	784	841
1000	0.0176	0.0242	0.117	0.120	0.436	626	493	540	465	1022	876	947

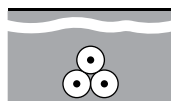

Fig. (a)

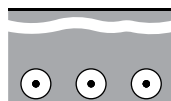

Fig. (b)

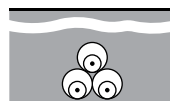

Fig. (c)

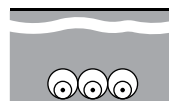

Fig. (d)

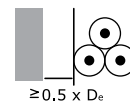

Fig. (e)



Fig. (f)

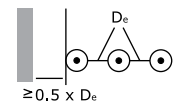

Fig. (g)

Laying Conditions: Ambient air temperature of 40 °C, Ambient ground temperature of 30 °C, Soil thermal resistivity of 1.5 K·m/W, Depth of laying of 0.8 m, and cable screens are bonded at both ends. In case of different laying conditions, appropriate correction (derating) factors from *Annex E* have to be applied to cater for the actual installation conditions.

Three-Core Cables, with Copper Conductors, XLPE Insulated, Wire Armoured and PVC Sheathed

APPLICATION

Suitable for installations indoors: mostly in power supply stations and outdoors: in cable ducts, underground, and on cable trays for industries, switch-boards and power stations. Due to the good laying and mechanical characteristics, this cable is suitable when mechanical protection is required or in applications where mechanical damages are expected to occur.

APPLICABLE STANDARDS

alfanar medium voltage cables are designed and tested to meet or exceed the requirements of IEC 60502-2 standard and/or BS 6622 standard with rated voltage 19 / 33 (36) kV. However, **alfanar** can also supply a range of alternative designs to meet customer-specified requirements.

CABLE CONSTRUCTION

Conductor

Plain annealed stranded circular compacted copper conductor (Class 2).

Conductor Screen

Extruded layer of a cross-linkable semi-conducting compound as a stress control layer.

Insulation

Extruded layer of cross-linked polyethylene (XLPE).

Insulation Screen

Extruded layer of a cross-linkable semi-conducting compound firmly bonded to the insulation.

Metallic Screen

Flat plain copper tape helically applied over the insulation screen with suitable overlap.

Filler

Non-hygroscopic polypropylene filler suitable for the cable's operating temperature.

Bedding

Extruded layer of Polyvinyl chloride (PVC).

Armouring

Single layer of round galvanized steel wires.

Outer Jacket

Extruded layer of Polyvinyl chloride (PVC).

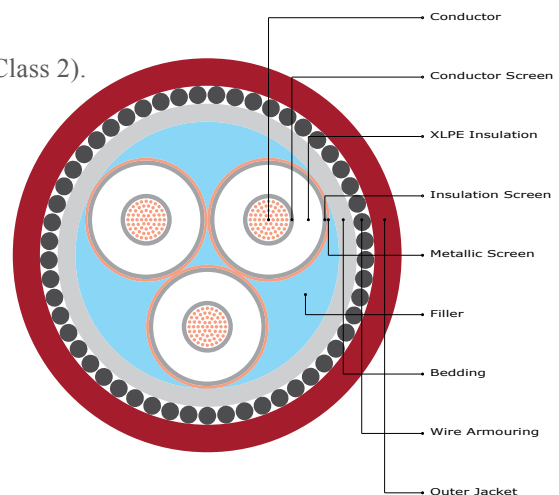

Note: The conductor screen, XLPE insulation and the insulation screen are extruded simultaneously in one process using triple extrusion method (Continuous Vulcanization Line). Triple extrusion method not only assures clean interfaces between the insulation and stress control layers, but also assures a construction free of Partial Discharge with high operational reliability.

TECHNICAL DATA

Rated voltage $U_0 / U (U_m)$	18 / 30 (36)	kV
Impulse test voltage (peak value)	170	kV
Power frequency test voltage for 5 minutes	63	kV
Max. conductor operating temperature at Normal conditions	90	°C
Max. conductor operating temperature at Emergency conditions	130	°C
Max. conductor operating temperature at Short circuit conditions	250	°C
Min. bending radius during installation in terms of cable outer diameter	12 \emptyset	

Constructional Data

Conductor		Insulation			Screen	Armour	Packing			Cable Code
Nominal area of conductor	Approx. conductor diameter	Thickness of insulation layers			Approx. metallic screen tape thickness	Wire diameter	Approx. overall diameter	Approx. overall weight	Standard cutting length $\pm 5\%$	
		C.S	XLPE	I.S						
mm ²	mm	Min.	Nom.	Min.	mm	mm	mm	kg / km	m	
50	8.10	0.3	8.0	0.3	0.076	3.15	74.8	9045	500	C318XM3BBWMDXXI0MF
70	9.70	0.3	8.0	0.3	0.076	3.15	78.5	10125	500	C319XM3BBWMDXXI0MF
95	11.30	0.3	8.0	0.3	0.076	3.15	82.5	11412	500	C345XM3BBWMDXXI0MF
120	12.60	0.3	8.0	0.3	0.076	3.15	85.7	12622	500	C346XM3BBWMDXXI0MF
150	14.10	0.3	8.0	0.3	0.076	3.15	89.2	13840	400	C347XM3BBWMDXXI0MU
185	15.80	0.3	8.0	0.3	0.076	3.15	93.3	15508	400	C348XM3BBWMDXXI0MU
240	18.10	0.3	8.0	0.3	0.076	3.15	98.8	17949	400	C349XM3BBWMDXXI0MU
300	20.50	0.3	8.0	0.3	0.076	3.15	104.4	20520	300	C350XM3BBWMDXXI0MT
400	23.10	0.3	8.0	0.3	0.076	3.15	110.8	23905	300	C351XM3BBWMDXXI0MT

Electrical Data

Nominal area of conductor	Electrical Characteristics					Continuous Current Ratings		
	Max. Conductor Resistance		Reactance (60 Hz)	Impedance (90 °C, 60 Hz)	Capacitance	Buried direct in the ground	In a buried duct	In air
	DC at 20 °C	AC at 90 °C				Fig. (a)	Fig. (b)	Fig. (c)
mm ²	Ω / km	Ω / km	Ω / km	Ω / km	$\mu\text{F} / \text{km}$	A	A	A
50	0.3870	0.4938	0.165	0.521	0.137	171	149	193
70	0.2680	0.3423	0.156	0.376	0.152	208	182	238
95	0.1930	0.2469	0.149	0.288	0.167	247	217	287
120	0.1530	0.1961	0.144	0.243	0.179	278	245	327
150	0.1240	0.1595	0.139	0.211	0.192	309	274	369
185	0.0991	0.1282	0.133	0.185	0.208	345	307	417
240	0.0754	0.0986	0.127	0.161	0.228	391	351	482
300	0.0601	0.0799	0.123	0.146	0.250	431	389	541
400	0.0470	0.0643	0.118	0.134	0.273	475	431	606

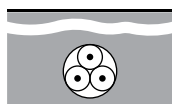

Fig. (a)

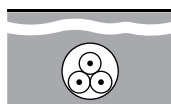

Fig. (b)



Fig. (c)

Laying Conditions: Ambient air temperature of 40 °C, Ambient ground temperature of 30 °C, Soil thermal resistivity of 1.5 K·m/W, Depth of laying of 0.8 m. and cable screens are bonded at both ends. In case of different laying conditions, appropriate correction (derating) factors from *Annex E* have to be applied to cater for the actual installation conditions.

Single-Core Cables, with Aluminum Conductors, XLPE Insulated and PVC Sheathed

APPLICATION

Suitable for installations indoors: mostly in power supply stations and outdoors: in cable ducts, underground, and on cable trays for industries, switch-boards and power stations.

APPLICABLE STANDARDS

alfanar medium voltage cables are designed and tested to meet or exceed the requirements of IEC 60502-2 standard. However, **alfanar** can also supply a range of alternative designs to meet customer-specified requirements.

CABLE CONSTRUCTION

Conductor

Stranded circular compacted aluminum conductor (Class 2).

Conductor Screen

Extruded layer of a cross-linkable semi-conducting compound as a stress control layer.

Insulation

Extruded layer of cross-linked polyethylene (XLPE).

Insulation Screen

Extruded layer of a cross-linkable semi-conducting compound firmly bonded to the insulation.

Metallic Screen

Flat plain copper tape helically applied over the insulation screen with suitable overlap.

Outer Jacket

Extruded layer of Polyvinyl chloride (PVC).

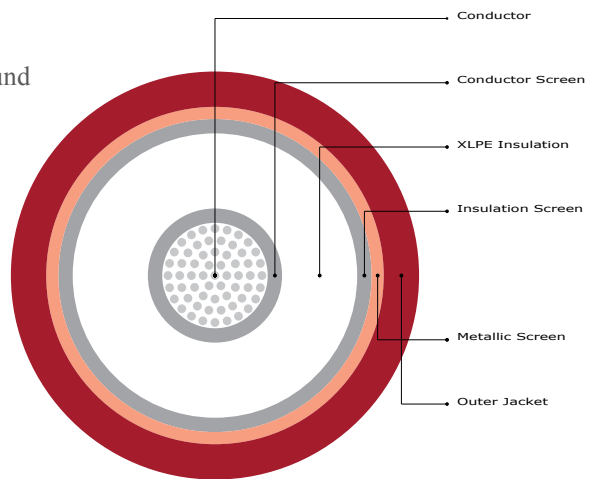

Note: The conductor screen, XLPE insulation and the insulation screen are extruded simultaneously in one process using triple extrusion method (Continuous Vulcanization Line). Triple extrusion method not only assures clean interfaces between the insulation and stress control layers, but also assures a construction free of Partial Discharge with high operational reliability.

TECHNICAL DATA

Rated voltage $U_0 / U (U_m)$	18 / 30 (36)	kV
Impulse test voltage (peak value)	170	kV
Power frequency test voltage for 5 minutes	63	kV
Max. conductor operating temperature at Normal conditions	90	°C
Max. conductor operating temperature at Emergency conditions	130	°C
Max. conductor operating temperature at Short circuit conditions	250	°C
Min. bending radius during installation in terms of cable outer diameter	20 Ø	

The above data is approximate and subject to manufacturing tolerance.

We reserve the right to change the above figures as a result of product development and/or changes in standard.

Constructional Data

Conductor		Insulation			Screen	Armour	Packing			Cable Code
Nominal area of conductor	Approx. conductor diameter	Thickness of insulation layers			Approx. metallic screen tape thickness	N / A	Approx. overall diameter	Approx. overall weight	Standard cutting length $\pm 5\%$	
		C.S	XLPE	I.S						
mm ²	mm	Min.	Nom.	Min.	mm	mm	mm	kg / km	m	
50	8.10	0.3	8.0	0.3	0.076	-	30.4	942	1000	A318XM1BB0MRDXXI0MR
70	9.70	0.3	8.0	0.3	0.076	-	32.0	1061	1000	A319XM1BB0MRDXXI0MR
95	11.30	0.3	8.0	0.3	0.076	-	33.8	1208	1000	A345XM1BB0MRDXXI0MR
120	12.60	0.3	8.0	0.3	0.076	-	35.1	1332	1000	A346XM1BB0MRDXXI0MR
150	14.10	0.3	8.0	0.3	0.076	-	36.8	1481	1000	A347XM1BB0MRDXXI0MR
185	15.80	0.3	8.0	0.3	0.076	-	38.5	1651	1000	A348XM1BB0MRDXXI0MR
240	18.10	0.3	8.0	0.3	0.076	-	41.0	1920	1000	A349XM1BB0MRDXXI0MR
300	20.50	0.3	8.0	0.3	0.076	-	43.6	2201	1000	A350XM1BB0MRDXXI0MR
400	23.10	0.3	8.0	0.3	0.076	-	46.4	2563	1000	A351XM1BB0MRDXXI0MR
500	26.50	0.3	8.0	0.3	0.076	-	50.0	3032	1000	A352XM1BB0MRDXXI0MR
630	30.05	0.3	8.0	0.3	0.076	-	53.8	3590	1000	A353XM1BB0MRDXXI0MR
800	34.00	0.3	8.0	0.3	0.076	-	58.1	4322	500	A354XM1BB0MRDXXI0MF
1000	40.00	0.3	8.0	0.3	0.076	-	65.7	5287	500	A755XM1BB0MRDXXI0MF

Electrical Data

Nominal area of conductor	Electrical Characteristics					Continuous Current Ratings						
	Max. Conductor Resistance		Reactance (60 Hz)	Impedance (90 °C, 60 Hz)	Capacitance	Buried direct in the ground		In single-way ducts		In air		
	DC at 20 °C	AC at 90 °C				Trefoil	Flat spaced	Trefoil	Flat touched	Trefoil	Flat touched	Flat spaced
	mm ²	Ω / km	Ω / km	Ω / km	Ω / km	$\mu\text{F} / \text{km}$	Fig. (a)	Fig. (b)	Fig. (c)	Fig. (d)	Fig. (e)	Fig. (f)
50	0.6410	0.8220	0.173	0.840	0.137	138	144	126	125	158	162	194
70	0.4430	0.5683	0.163	0.591	0.152	168	176	154	154	198	203	242
95	0.3200	0.4107	0.156	0.439	0.167	201	210	184	184	242	248	295
120	0.2530	0.3249	0.150	0.358	0.179	228	237	210	209	279	286	340
150	0.2060	0.2648	0.145	0.302	0.192	254	266	236	235	318	326	387
185	0.1640	0.2112	0.139	0.253	0.208	287	300	268	267	367	376	446
240	0.1250	0.1616	0.134	0.210	0.228	333	346	311	309	435	446	527
300	0.1000	0.1300	0.129	0.183	0.250	375	389	352	349	503	514	606
400	0.0778	0.1022	0.124	0.161	0.273	427	441	403	398	586	598	703
500	0.0605	0.0808	0.120	0.144	0.303	485	499	461	453	685	697	818
630	0.0469	0.0645	0.116	0.132	0.335	547	560	525	511	793	804	941
800	0.0367	0.0526	0.112	0.124	0.371	610	620	590	570	908	916	1070
1000	0.0291	0.0386	0.107	0.114	0.436	728	703	692	657	1131	1127	1265

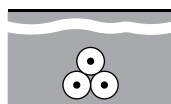

Fig. (a)

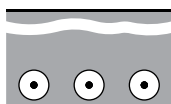

Fig. (b)

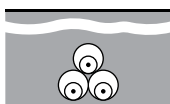

Fig. (c)

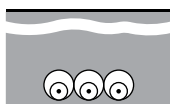

Fig. (d)

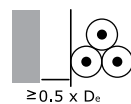

Fig. (e)

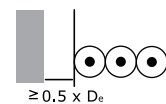

Fig. (f)

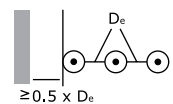

Fig. (g)

Laying Conditions: Ambient air temperature of 40 °C, Ambient ground temperature of 30 °C, Soil thermal resistivity of 1.5 K·m/W, Depth of laying of 0.8 m, and cable screens are bonded at both ends. In case of different laying conditions, appropriate correction (derating) factors from *Annex E* have to be applied to cater for the actual installation conditions.

Three-Core Cables, with Aluminum Conductors, XLPE Insulated and PVC Sheathed

APPLICATION

Suitable for installations indoors: mostly in power supply stations and outdoors: in cable ducts, underground, and on cable trays for industries, switch-boards and power stations.

APPLICABLE STANDARDS

alfanar medium voltage cables are designed and tested to meet or exceed the requirements of IEC 60502-2 standard. However, **alfanar** can also supply a range of alternative designs to meet customer-specified requirements.

CABLE CONSTRUCTION

Conductor

Stranded circular compacted aluminum conductor (Class 2).

Conductor Screen

Extruded layer of a cross-linkable semi-conducting compound as a stress control layer.

Insulation

Extruded layer of cross-linked polyethylene (XLPE).

Insulation Screen

Extruded layer of a cross-linkable semi-conducting compound firmly bonded to the insulation.

Metallic Screen

Flat plain copper tape helically applied over the insulation screen with suitable overlap.

Filler

Non-hygroscopic polypropylene filler suitable for the cable's operating temperature.

Outer Jacket

Extruded layer of Polyvinyl chloride (PVC).

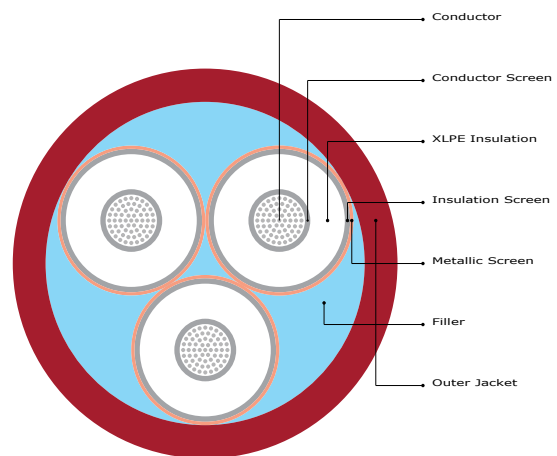

Note: The conductor screen, XLPE insulation and the insulation screen are extruded simultaneously in one process using triple extrusion method (Continuous Vulcanization Line). Triple extrusion method not only assures clean interfaces between the insulation and stress control layers, but also assures a construction free of Partial Discharge with high operational reliability.

TECHNICAL DATA

Rated voltage $U_0 / U (U_m)$	18 / 30 (36)	kV
Impulse test voltage (peak value)	170	kV
Power frequency test voltage for 5 minutes	63	kV
Max. conductor operating temperature at Normal conditions	90	°C
Max. conductor operating temperature at Emergency conditions	130	°C
Max. conductor operating temperature at Short circuit conditions	250	°C
Min. bending radius during installation in terms of cable outer diameter	15 Ø	

The above data is approximate and subject to manufacturing tolerance.

We reserve the right to change the above figures as a result of product development and/or changes in standard.

Constructional Data

Conductor		Insulation			Screen	Armour	Packing			Cable Code
Nominal area of conductor	Approx. conductor diameter	Thickness of insulation layers			Approx. metallic screen tape thickness	N / A	Approx. overall diameter	Approx. overall weight	Standard cutting length $\pm 5\%$	
		C.S.	XLPE	I.S.						
mm ²	mm	Min.	Nom.	Min.	mm	mm	mm	kg / km	m	
50	8.10	0.3	8.0	0.3	0.076	-	63.7	3348	500	A318XM3BB0MRDXXI0MF
70	9.70	0.3	8.0	0.3	0.076	-	67.4	3800	500	A319XM3BB0MRDXXI0MF
95	11.30	0.3	8.0	0.3	0.076	-	71.0	4288	500	A345XM3BB0MRDXXI0MF
120	12.60	0.3	8.0	0.3	0.076	-	74.0	4748	500	A346XM3BB0MRDXXI0MF
150	14.10	0.3	8.0	0.3	0.076	-	77.5	5249	500	A347XM3BB0MRDXXI0MF
185	15.80	0.3	8.0	0.3	0.076	-	81.4	5881	500	A348XM3BB0MRDXXI0MF
240	18.10	0.3	8.0	0.3	0.076	-	86.7	6822	400	A349XM3BB0MRDXXI0MU
300	20.50	0.3	8.0	0.3	0.076	-	92.1	7778	400	A350XM3BB0MRDXXI0MU
400	23.10	0.3	8.0	0.3	0.076	-	98.3	9082	350	A351XM3BB0MRDXXI0MV

Electrical Data

Nominal area of conductor	Electrical Characteristics					Continuous Current Ratings		
	Max. Conductor Resistance		Reactance (60 Hz)	Impedance (90 °C, 60 Hz)	Capacitance	Buried direct in the ground	In a buried duct	In air
	DC at 20 °C	AC at 90 °C				Fig. (a)	Fig. (b)	Fig. (c)
mm ²	Ω / km	Ω / km	Ω / km	Ω / km	$\mu\text{F} / \text{km}$	A	A	A
50	0.6410	0.8220	0.165	0.839	0.137	139	117	158
70	0.4430	0.5683	0.156	0.589	0.152	169	144	197
95	0.3200	0.4107	0.149	0.437	0.167	202	172	240
120	0.2530	0.3250	0.144	0.355	0.179	229	197	276
150	0.2060	0.2649	0.139	0.299	0.192	256	221	313
185	0.1640	0.2114	0.133	0.250	0.208	289	252	361
240	0.1250	0.1618	0.127	0.206	0.228	335	293	425
300	0.1000	0.1302	0.123	0.179	0.250	377	333	488
400	0.0778	0.1025	0.118	0.156	0.273	429	382	566

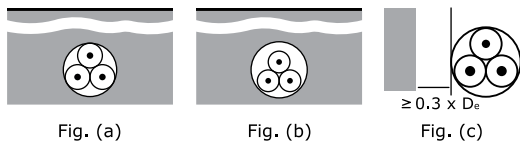

Laying Conditions: Ambient air temperature of 40 °C, Ambient ground temperature of 30 °C, Soil thermal resistivity of 1.5 K·m/W, Depth of laying of 0.8 m, and cable screens are bonded at both ends. In case of different laying conditions, appropriate correction (derating) factors from *Annex E* have to be applied to cater for the actual installation conditions.

Single-Core Cables, with Aluminum Conductors, XLPE Insulated, Tape Armoured and PVC Sheathed

APPLICATION

Suitable for installations indoors: mostly in power supply stations and outdoors: in cable ducts, underground, and on cable trays for industries, switch-boards and power stations. Due to the good laying and mechanical characteristics, this cable is suitable when mechanical protection is required or in applications where mechanical damages are expected to occur.

APPLICABLE STANDARDS

alfanar medium voltage cables are designed and tested to meet or exceed the requirements of IEC 60502-2 standard. However, **alfanar** can also supply a range of alternative designs to meet customer-specified requirements.

CABLE CONSTRUCTION

Conductor

Stranded circular compacted aluminum conductor (Class 2).

Conductor Screen

Extruded layer of a cross-linkable semi-conducting compound as a stress control layer.

Insulation

Extruded layer of cross-linked polyethylene (XLPE).

Insulation Screen

Extruded layer of a cross-linkable semi-conducting compound firmly bonded to the insulation.

Metallic Screen

Flat plain copper tape helically applied over the insulation screen with suitable overlap.

Bedding

Extruded layer of Polyvinyl chloride (PVC).

Armouring

Double layer of non-magnetic (aluminum) tapes.

Outer Jacket

Extruded layer of Polyvinyl chloride (PVC).

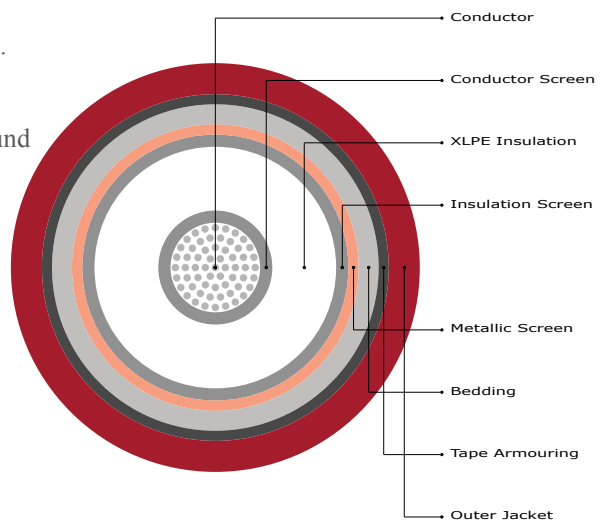

Note: The conductor screen, XLPE insulation and the insulation screen are extruded simultaneously in one process using triple extrusion method (Continuous Vulcanization Line). Triple extrusion method not only assures clean interfaces between the insulation and stress control layers, but also assures a construction free of Partial Discharge with high operational reliability.

TECHNICAL DATA

Rated voltage $U_0 / U (U_m)$	18 / 30 (36)	kV
Impulse test voltage (peak value)	170	kV
Power frequency test voltage for 5 minutes	63	kV
Max. conductor operating temperature at Normal conditions	90	°C
Max. conductor operating temperature at Emergency conditions	130	°C
Max. conductor operating temperature at Short circuit conditions	250	°C
Min. bending radius during installation in terms of cable outer diameter	15 Ø	

The above data is approximate and subject to manufacturing tolerance.

We reserve the right to change the above figures as a result of product development and/or changes in standard.

Constructional Data

Conductor		Insulation			Screen	Armour	Packing			Cable Code
Nominal area of conductor	Approx. conductor diameter	Thickness of insulation layers			Approx. metallic screen tape thickness	Tape thickness	Approx. overall diameter	Approx. overall weight	Standard cutting length $\pm 5\%$	
		C.S	XLPE	I.S						
mm ²	mm	Min.	Nom.	Min.	mm	mm	mm	kg / km	m	
50	8.10	0.3	8.0	0.3	0.076	0.50	35.0	1338	1000	A318XM1BBBMRDXXIOMR
70	9.70	0.3	8.0	0.3	0.076	0.50	36.8	1495	1000	A319XM1BBBMRDXXIOMR
95	11.30	0.3	8.0	0.3	0.076	0.50	38.4	1646	1000	A345XM1BBBMRDXXIOMR
120	12.60	0.3	8.0	0.3	0.076	0.50	39.9	1805	1000	A346XM1BBBMRDXXIOMR
150	14.10	0.3	8.0	0.3	0.076	0.50	41.6	1975	1000	A347XM1BBBMRDXXIOMR
185	15.80	0.3	8.0	0.3	0.076	0.50	43.5	2189	1000	A348XM1BBBMRDXXIOMR
240	18.10	0.3	8.0	0.3	0.076	0.50	46.0	2491	1000	A349XM1BBBMRDXXIOMR
300	20.50	0.3	8.0	0.3	0.076	0.50	48.6	2805	1000	A350XM1BBBMRDXXIOMR
400	23.10	0.3	8.0	0.3	0.076	0.50	51.4	3204	1000	A351XM1BBBMRDXXIOMR
500	26.50	0.3	8.0	0.3	0.076	0.50	55.2	3748	1000	A352XM1BBBMRDXXIOMR
630	30.05	0.3	8.0	0.3	0.076	0.50	59.4	4416	500	A353XM1BBBMRDXXIOMF
800	34.00	0.3	8.0	0.3	0.076	0.50	63.7	5211	500	A354XM1BBBMRDXXIOMF
1000	40.00	0.3	8.0	0.3	0.076	0.50	71.5	6323	500	A755XM1BBBMRDXXIOMF

Electrical Data

Nominal area of conductor	Electrical Characteristics					Continuous Current Ratings						
	Max. Conductor Resistance		Reactance (60 Hz)	Impedance (90 °C, 60 Hz)	Capacitance	Buried direct in the ground		In single-way ducts		In air		
	DC at 20 °C	AC at 90 °C				Trefoil	Flat spaced	Trefoil	Flat touched	Trefoil	Flat touched	Flat spaced
	mm ²	Ω / km	Ω / km	Ω / km	Ω / km	$\mu\text{F} / \text{km}$	A	A	A	A	A	A
50	0.6410	0.8220	0.183	0.842	0.137	138	143	128	127	163	166	193
70	0.4430	0.5682	0.174	0.594	0.152	168	175	156	156	203	207	241
95	0.3200	0.4107	0.165	0.443	0.167	201	208	187	185	246	252	292
120	0.2530	0.3249	0.160	0.362	0.179	227	235	212	210	284	290	335
150	0.2060	0.2648	0.155	0.307	0.192	254	261	237	235	323	329	380
185	0.1640	0.2112	0.149	0.258	0.208	287	294	269	265	371	378	435
240	0.1250	0.1615	0.142	0.215	0.228	331	337	311	305	439	445	510
300	0.1000	0.1298	0.137	0.189	0.250	374	376	350	342	505	511	582
400	0.0778	0.1019	0.132	0.167	0.273	424	422	399	387	586	590	668
500	0.0605	0.0805	0.127	0.150	0.303	481	472	454	436	682	683	768
630	0.0469	0.0640	0.123	0.139	0.335	540	513	508	479	785	775	858
800	0.0367	0.0521	0.119	0.130	0.371	597	549	560	517	891	867	944
1000	0.0291	0.0385	0.114	0.120	0.436	694	593	635	569	1078	1022	1063

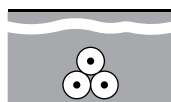

Fig. (a)

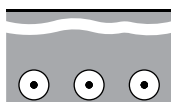

Fig. (b)

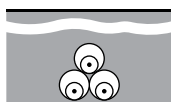

Fig. (c)

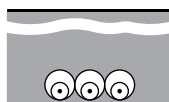

Fig. (d)

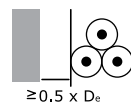

Fig. (e)



Fig. (f)

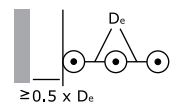

Fig. (g)

Laying Conditions: Ambient air temperature of 40 °C, Ambient ground temperature of 30 °C, Soil thermal resistivity of 1.5 K·m/W, Depth of laying of 0.8 m, and cable screens are bonded at both ends. In case of different laying conditions, appropriate correction (derating) factors from *Annex E* have to be applied to cater for the actual installation conditions.

Three-Core Cables, with Aluminum Conductors, XLPE Insulated, Tape Armoured and PVC Sheathed

APPLICATION

Suitable for installations indoors: mostly in power supply stations and outdoors: in cable ducts, underground, and on cable trays for industries, switch-boards and power stations. Due to the good laying and mechanical characteristics, this cable is suitable when mechanical protection is required or in applications where mechanical damages are expected to occur.

APPLICABLE STANDARDS

alfanar medium voltage cables are designed and tested to meet or exceed the requirements of IEC 60502-2 standard. However, **alfanar** can also supply a range of alternative designs to meet customer-specified requirements.

CABLE CONSTRUCTION

Conductor

Stranded circular compacted aluminum conductor (Class 2).

Conductor Screen

Extruded layer of a cross-linkable semi-conducting compound as a stress control layer.

Insulation

Extruded layer of cross-linked polyethylene (XLPE).

Insulation Screen

Extruded layer of a cross-linkable semi-conducting compound firmly bonded to the insulation.

Metallic Screen

Flat plain copper tape helically applied over the insulation screen with suitable overlap.

Filler

Non-hygroscopic polypropylene filler suitable for the cable's operating temperature.

Bedding

Extruded layer of Polyvinyl chloride (PVC).

Armouring

Double layer of galvanized steel tapes.

Outer Jacket

Extruded layer of Polyvinyl chloride (PVC).

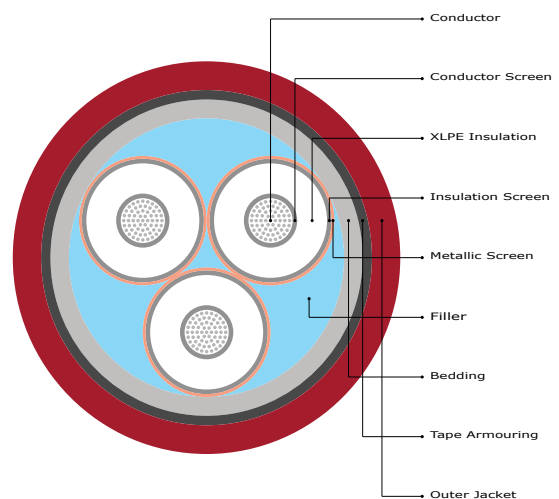

Note: The conductor screen, XLPE insulation and the insulation screen are extruded simultaneously in one process using triple extrusion method (Continuous Vulcanization Line). Triple extrusion method not only assures clean interfaces between the insulation and stress control layers, but also assures a construction free of Partial Discharge with high operational reliability.

TECHNICAL DATA

Rated voltage $U_0 / U (U_m)$	18 / 30 (36)	kV
Impulse test voltage (peak value)	170	kV
Power frequency test voltage for 5 minutes	63	kV
Max. conductor operating temperature at Normal conditions	90	°C
Max. conductor operating temperature at Emergency conditions	130	°C
Max. conductor operating temperature at Short circuit conditions	250	°C
Min. bending radius during installation in terms of cable outer diameter	12 \emptyset	

Constructional Data

Conductor		Insulation			Screen	Armour	Packing			Cable Code
Nominal area of conductor	Approx. conductor diameter	Thickness of insulation layers			Approx. metallic screen tape thickness	Tape thickness	Approx. overall diameter	Approx. overall weight	Standard cutting length $\pm 5\%$	
		C.S.	XLPE	I.S.						
		Min.	Nom.	Min.						
mm ²	mm	mm	mm	mm	mm	mm	kg / km	m		
50	8.10	0.3	8.0	0.3	0.076	0.50	69.7	5055	500	A318XM3BBGMRDXXI0MF
70	9.70	0.3	8.0	0.3	0.076	0.50	73.4	5602	500	A319XM3BBGMRDXXI0MF
95	11.30	0.3	8.0	0.3	0.076	0.50	77.2	6224	500	A345XM3BBGMRDXXI0MF
120	12.60	0.3	8.0	0.3	0.076	0.80	81.8	7597	500	A346XM3BBGMRDXXI0MF
150	14.10	0.3	8.0	0.3	0.076	0.80	85.3	8226	500	A347XM3BBGMRDXXI0MF
185	15.80	0.3	8.0	0.3	0.076	0.80	89.4	9050	400	A348XM3BBGMRDXXI0MU
240	18.10	0.3	8.0	0.3	0.076	0.80	94.9	10237	400	A349XM3BBGMRDXXI0MU
300	20.50	0.3	8.0	0.3	0.076	0.80	100.5	11451	350	A350XM3BBGMRDXXI0MV
400	23.10	0.3	8.0	0.3	0.076	0.80	106.9	13044	300	A351XM3BBGMRDXXI0MT

Electrical Data

Nominal area of conductor	Electrical Characteristics					Continuous Current Ratings		
	Max. Conductor Resistance		Reactance (60 Hz)	Impedance (90 °C, 60 Hz)	Capacitance	Buried direct in the ground	In a buried duct	In air
	DC at 20 °C	AC at 90 °C				Fig. (a)	Fig. (b)	Fig. (c)
mm ²	Ω / km	Ω / km	Ω / km	Ω / km	$\mu\text{F} / \text{km}$	A	A	A
50	0.6410	0.8220	0.165	0.839	0.137	133	114	147
70	0.4430	0.5683	0.156	0.589	0.152	162	140	183
95	0.3200	0.4107	0.149	0.437	0.167	192	168	221
120	0.2530	0.3250	0.144	0.355	0.179	218	191	253
150	0.2060	0.2649	0.139	0.299	0.192	244	215	287
185	0.1640	0.2114	0.133	0.250	0.208	275	244	328
240	0.1250	0.1618	0.127	0.206	0.228	318	284	385
300	0.1000	0.1302	0.123	0.179	0.250	357	321	439
400	0.0778	0.1025	0.118	0.156	0.273	406	368	508

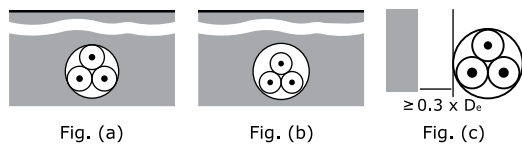

Laying Conditions: Ambient air temperature of 40 °C, Ambient ground temperature of 30 °C, Soil thermal resistivity of 1.5 K·m/W, Depth of laying of 0.8 m. and cable screens are bonded at both ends. In case of different laying conditions, appropriate correction (derating) factors from *Annex E* have to be applied to cater for the actual installation conditions.

Single-Core Cables, with Aluminum Conductors, XLPE Insulated, Wire Armoured and PVC Sheathed

APPLICATION

Suitable for installations indoors: mostly in power supply stations and outdoors: in cable ducts, underground, and on cable trays for industries, switch-boards and power stations. Due to the good laying and mechanical characteristics, this cable is suitable when mechanical protection is required or in applications where mechanical damages are expected to occur.

APPLICABLE STANDARDS

alfanar medium voltage cables are designed and tested to meet or exceed the requirements of IEC 60502-2 standard and/or BS 6622 standard with rated voltage 19 / 33 (36) kV. However, **alfanar** can also supply a range of alternative designs to meet customer-specified requirements.

CABLE CONSTRUCTION

Conductor

Stranded circular compacted aluminum conductor (Class 2).

Conductor Screen

Extruded layer of a cross-linkable semi-conducting compound as a stress control layer.

Insulation

Extruded layer of cross-linked polyethylene (XLPE).

Insulation Screen

Extruded layer of a cross-linkable semi-conducting compound firmly bonded to the insulation.

Metallic Screen

Flat plain copper tape helically applied over the insulation screen with suitable overlap.

Bedding

Extruded layer of Polyvinyl chloride (PVC).

Armouring

Single layer of round non-magnetic (aluminum) wires.

Outer Jacket

Extruded layer of Polyvinyl chloride (PVC).

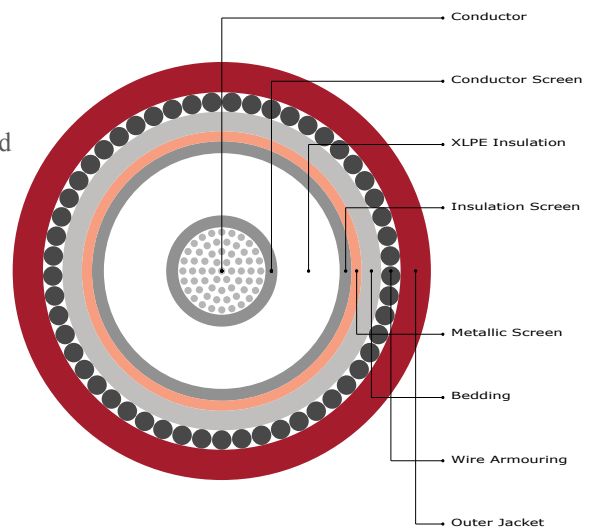

Note: The conductor screen, XLPE insulation and the insulation screen are extruded simultaneously in one process using triple extrusion method (Continuous Vulcanization Line). Triple extrusion method not only assures clean interfaces between the insulation and stress control layers, but also assures a construction free of Partial Discharge with high operational reliability.

TECHNICAL DATA

Rated voltage $U_0 / U (U_m)$	18 / 30 (36)	kV
Impulse test voltage (peak value)	170	kV
Power frequency test voltage for 5 minutes	63	kV
Max. conductor operating temperature at Normal conditions	90	°C
Max. conductor operating temperature at Emergency conditions	130	°C
Max. conductor operating temperature at Short circuit conditions	250	°C
Min. bending radius during installation in terms of cable outer diameter	15 Ø	

The above data is approximate and subject to manufacturing tolerance.

We reserve the right to change the above figures as a result of product development and/or changes in standard.

Constructional Data

Conductor		Insulation			Screen	Armour	Packing			Cable Code
Nominal area of conductor	Approx. conductor diameter	Thickness of insulation layers			Approx. metallic screen tape thickness	Wire diameter	Approx. overall diameter	Approx. overall weight	Standard cutting length $\pm 5\%$	
		C.S.	XLPE	I.S.						
mm ²	mm	Min.	Nom.	Min.	mm	mm	mm	kg / km	m	
50	8.10	0.3	8.0	0.3	0.076	2.00	37.7	1619	1000	A318XM1BBAMRDXXI0MR
70	9.70	0.3	8.0	0.3	0.076	2.00	39.3	1767	1000	A319XM1BBAMRDXXI0MR
95	11.30	0.3	8.0	0.3	0.076	2.00	41.1	1948	1000	A345XM1BBAMRDXXI0MR
120	12.60	0.3	8.0	0.3	0.076	2.00	42.4	2098	1000	A346XM1BBAMRDXXI0MR
150	14.10	0.3	8.0	0.3	0.076	2.50	45.3	2435	1000	A347XM1BBAMRDXXI0MR
185	15.80	0.3	8.0	0.3	0.076	2.50	47.2	2671	1000	A348XM1BBAMRDXXI0MR
240	18.10	0.3	8.0	0.3	0.076	2.50	49.7	3006	1000	A349XM1BBAMRDXXI0MR
300	20.50	0.3	8.0	0.3	0.076	2.50	52.3	3350	1000	A350XM1BBAMRDXXI0MR
400	23.10	0.3	8.0	0.3	0.076	2.50	55.1	3780	1000	A351XM1BBAMRDXXI0MR
500	26.50	0.3	8.0	0.3	0.076	2.50	58.9	4364	1000	A352XM1BBAMRDXXI0MR
630	30.05	0.3	8.0	0.3	0.076	2.50	63.1	5074	500	A353XM1BBAMRDXXI0MF
800	34.00	0.3	8.0	0.3	0.076	2.50	67.4	5921	500	A354XM1BBAMRDXXI0MF
1000	40.00	0.3	8.0	0.3	0.076	2.50	75.2	7111	500	A755XM1BBAMRDXXI0MF

Electrical Data

Nominal area of conductor	Electrical Characteristics					Continuous Current Ratings						
	Max. Conductor Resistance		Reactance (60 Hz)	Impedance (90 °C, 60 Hz)	Capacitance	Buried direct in the ground		In single-way ducts		In air		
	DC at 20 °C	AC at 90 °C				Trefoil	Flat spaced	Trefoil	Flat touched	Trefoil	Flat touched	Flat spaced
	mm ²	Ω / km	Ω / km	Ω / km	Ω / km	$\mu\text{F} / \text{km}$	A	A	A	A	A	A
50	0.6410	0.8220	0.189	0.843	0.137	139	142	128	127	166	169	194
70	0.4430	0.5682	0.179	0.596	0.152	169	171	156	153	207	210	240
95	0.3200	0.4107	0.171	0.445	0.167	200	200	185	180	250	252	288
120	0.2530	0.3249	0.165	0.364	0.179	225	221	208	200	288	288	326
150	0.2060	0.2648	0.161	0.310	0.192	251	242	230	220	326	324	364
185	0.1640	0.2111	0.155	0.262	0.208	281	266	257	244	372	368	409
240	0.1250	0.1614	0.148	0.219	0.228	321	296	291	272	435	424	467
300	0.1000	0.1297	0.143	0.193	0.250	357	320	322	297	495	477	520
400	0.0778	0.1018	0.137	0.171	0.273	394	344	351	320	562	530	577
500	0.0605	0.0803	0.132	0.154	0.303	437	372	386	347	640	593	643
630	0.0469	0.0638	0.128	0.143	0.335	479	399	421	374	721	656	709
800	0.0367	0.0518	0.123	0.134	0.371	518	425	453	399	800	715	775
1000	0.0291	0.0385	0.117	0.124	0.436	561	463	495	435	908	805	878

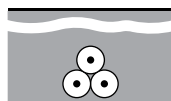

Fig. (a)

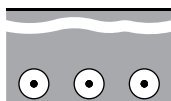

Fig. (b)

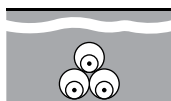

Fig. (c)

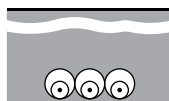

Fig. (d)

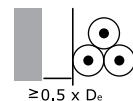

Fig. (e)

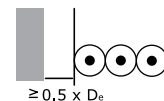

Fig. (f)

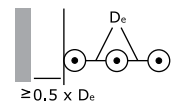

Fig. (g)

Laying Conditions: Ambient air temperature of 40 °C, Ambient ground temperature of 30 °C, Soil thermal resistivity of 1.5 K·m/W, Depth of laying of 0.8 m, and cable screens are bonded at both ends. In case of different laying conditions, appropriate correction (derating) factors from *Annex E* have to be applied to cater for the actual installation conditions.

Three-Core Cables, with Aluminum Conductors, XLPE Insulated, Wire Armoured and PVC Sheathed

APPLICATION

Suitable for installations indoors: mostly in power supply stations and outdoors: in cable ducts, underground, and on cable trays for industries, switch-boards and power stations. Due to the good laying and mechanical characteristics, this cable is suitable when mechanical protection is required or in applications where mechanical damages are expected to occur.

APPLICABLE STANDARDS

alfanar medium voltage cables are designed and tested to meet or exceed the requirements of IEC 60502-2 standard and/or BS 6622 standard with rated voltage 19 / 33 (36) kV. However, **alfanar** can also supply a range of alternative designs to meet customer-specified requirements.

CABLE CONSTRUCTION

Conductor

Stranded circular compacted aluminum conductor (Class 2).

Conductor Screen

Extruded layer of a cross-linkable semi-conducting compound as a stress control layer.

Insulation

Extruded layer of cross-linked polyethylene (XLPE).

Insulation Screen

Extruded layer of a cross-linkable semi-conducting compound firmly bonded to the insulation.

Metallic Screen

Flat plain copper tape helically applied over the insulation screen with suitable overlap.

Filler

Non-hygroscopic polypropylene filler suitable for the cable's operating temperature.

Bedding

Extruded layer of Polyvinyl chloride (PVC).

Armouring

Single layer of round galvanized steel wires.

Outer Jacket

Extruded layer of Polyvinyl chloride (PVC).

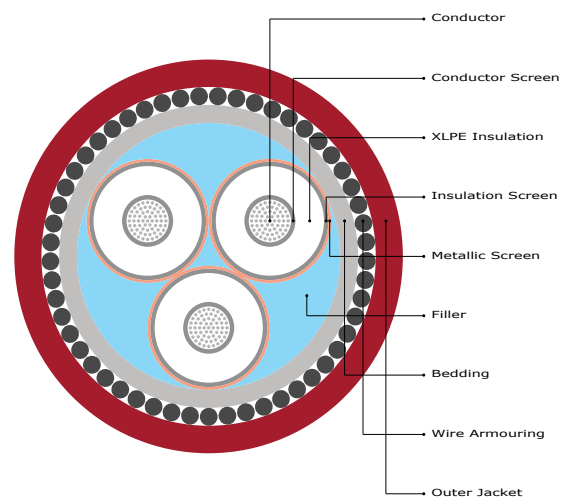

Note: The conductor screen, XLPE insulation and the insulation screen are extruded simultaneously in one process using triple extrusion method (Continuous Vulcanization Line). Triple extrusion method not only assures clean interfaces between the insulation and stress control layers, but also assures a construction free of Partial Discharge with high operational reliability.

TECHNICAL DATA

Rated voltage $U_0 / U (U_m)$	18 / 30 (36)	kV
Impulse test voltage (peak value)	170	kV
Power frequency test voltage for 5 minutes	63	kV
Max. conductor operating temperature at Normal conditions	90	°C
Max. conductor operating temperature at Emergency conditions	130	°C
Max. conductor operating temperature at Short circuit conditions	250	°C
Min. bending radius during installation in terms of cable outer diameter	12 \emptyset	

Constructional Data

Conductor		Insulation			Screen	Armour	Packing			Cable Code
Nominal area of conductor	Approx. conductor diameter	Thickness of insulation layers			Approx. metallic screen tape thickness	Wire diameter	Approx. overall diameter	Approx. overall weight	Standard cutting length $\pm 5\%$	
		C.S.	XLPE	I.S.						
mm ²	mm	Min.	Nom.	Min.	mm	mm	mm	kg / km	m	
50	8.10	0.3	8.0	0.3	0.076	3.15	74.8	8168	500	A318XM3BBWMDXXI0MF
70	9.70	0.3	8.0	0.3	0.076	3.15	78.5	8871	500	A319XM3BBWMDXXI0MF
95	11.30	0.3	8.0	0.3	0.076	3.15	82.5	9687	500	A345XM3BBWMDXXI0MF
120	12.60	0.3	8.0	0.3	0.076	3.15	85.7	10429	500	A346XM3BBWMDXXI0MF
150	14.10	0.3	8.0	0.3	0.076	3.15	89.2	11182	400	A347XM3BBWMDXXI0MU
185	15.80	0.3	8.0	0.3	0.076	3.15	93.3	12115	400	A348XM3BBWMDXXI0MU
240	18.10	0.3	8.0	0.3	0.076	3.15	98.8	13518	400	A349XM3BBWMDXXI0MU
300	20.50	0.3	8.0	0.3	0.076	3.15	104.4	14940	300	A350XM3BBWMDXXI0MT
400	23.10	0.3	8.0	0.3	0.076	3.15	110.8	16735	300	A351XM3BBWMDXXI0MT

Electrical Data

Nominal area of conductor	Electrical Characteristics					Continuous Current Ratings		
	Max. Conductor Resistance		Reactance (60 Hz)	Impedance (90 °C, 60 Hz)	Capacitance	Buried direct in the ground	In a buried duct	In air
	DC at 20 °C	AC at 90 °C				Fig. (a)	Fig. (b)	Fig. (c)
mm ²	Ω / km	Ω / km	Ω / km	Ω / km	$\mu\text{F} / \text{km}$	A	A	A
50	0.6410	0.8220	0.165	0.839	0.137	133	116	150
70	0.4430	0.5683	0.156	0.589	0.152	162	142	185
95	0.3200	0.4107	0.149	0.437	0.167	193	169	224
120	0.2530	0.3250	0.144	0.355	0.179	217	192	256
150	0.2060	0.2649	0.139	0.299	0.192	243	215	289
185	0.1640	0.2114	0.133	0.250	0.208	273	243	329
240	0.1250	0.1618	0.127	0.206	0.228	312	280	384
300	0.1000	0.1302	0.123	0.179	0.250	348	314	434
400	0.0778	0.1025	0.118	0.156	0.273	390	354	495

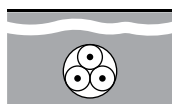

Fig. (a)

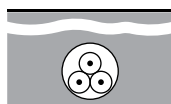

Fig. (b)



Fig. (c)

Laying Conditions: Ambient air temperature of 40 °C, Ambient ground temperature of 30 °C, Soil thermal resistivity of 1.5 K·m/W, Depth of laying of 0.8 m, and cable screens are bonded at both ends. In case of different laying conditions, appropriate correction (derating) factors from *Annex E* have to be applied to cater for the actual installation conditions.

Cables For Special Applications

Lead Sheathed Cables

Construction

Main constructions are as explained for the various types and voltage grades of medium voltage cables. Lead sheath is applied over an extruded bedding layer.

Application

The Lead Sheath Cables are suitable for outdoor installations in damp or wet locations, in chemical or petroleum plants, or any hostile environment where protection against hydrocarbons or other aggressive chemical substances is required.

Main properties

- Radially watertight
- Corrosion resistant
- Where necessary, it is available with the longitudinal watertight protection
- Suitable for use in hostile environment or underground
- Especially suitable for submarine installation
- Resistant to aggressive chemical substances
- Offer good protection against rodents
- Lead sheath acts as an additional metallic screen when needed



Low Smoke Halogen Free Cables

Construction

Main constructions are as explained for the various types and voltage grades of medium voltage cables, except that the cables are specially constructed using low smoke, halogen free materials/compounds.

Application

The Low Smoke Halogen Free power cables with enhanced characteristics in case of fire are used for applications where harm to human life and damage to property must be prevented in the event of fire, e.g. in industrial installations, commercial establishments, hotels, airports, underground stations, railway stations, hospitals, banks, schools, etc.

Main properties

- Reduced smoke and toxic gases emission in the event of fire
- Reduced acid gases emission in the event of fire
- Excellent flame retardant properties



Smoke density 3 m test cube (IEC 61034)

Other Types / Characteristics

Various types of constructions can be applied to meet special requirements of the customers, that is:

- Special design using water blocking (swellable) tapes, yarns, or powder to ensure the continuous longitudinal water protection against water ingress along the cable length
- Special design using aluminum laminated tape to ensure the continuous radial water protection against water ingress along the cable length
- Tree-Retardant Cross-linked polyethylene (XLPE) insulation
- Insulation screen of cold strippable semi-conducting compound capable of removal for jointing and terminating
- Copper tape screen of thickness other than 0.076 mm (3 mil) can be used upon a customer's request, e.g. 0.1 mm and 0.125 mm (5 mil)
- Copper wires screen where a high earth fault current is required
- Bare or insulated stranded copper grounding conductor, placed in the interstices between cores of three-core cables
- Sheathing compound other than Polyvinyl chloride (PVC) can be used upon a customer's request, e.g. LLDPE, LDPE, MDPE and HDPE sheathing compounds
- Extruded semi-conducting layer on the cable jacket, if a DC voltage test on the cable jacket is required

Cables can also be designed for specific requirements, that is:

- Oil resistance
- UV resistance
- Termite resistance
- Hydrocarbon resistance
- Acid and alkaline resistance
- Installation in wet locations
- Flame retardant to IEC 60332-3 or BS EN 50266-2 standards, Category A, B, C, or D



Other possibilities:

- Conductors with cross-sectional area of up to 3000 mm² depending on the type of cable
- Delivery lengths different from standard lengths
- Deliveries on steel drums of a flange diameter up to 4000 mm and a carrying capacity up to 25 tons
- Manufacturing according to other national or international norms/standards

Annex A: Continuous Current Ratings

A.1 General

This annexure deals solely with the steady-state continuous current ratings of single-core and three-core cables having extruded insulation. The tabulated current ratings provided in this catalogue have been calculated for cables having a rated voltage of 6/10 kV and constructions as detailed in each relevant type.

These ratings can be applied to cables of similar constructions in the voltage range of 3.6/6 kV to 18/30 kV.

Some parameters such as screen cross-sectional area and over sheath thickness have an influence on the rating of large cables. In addition, the method of screen bonding has to be taken into account in the rating of single-core cables.

The tabulated current ratings in this catalogue have been calculated using the methods set out in IEC 60287

A.2 Cable constructions

The cable constructions and dimensions for which current ratings have been tabulated in this catalogue are based on those given in the constructional data for each cable type. The constructions and dimensions used are based on IEC 60502-2 (BS 6622 where applicable) standard and not related to specific national designs but reflect different model cables.

A.3 Temperatures

The maximum conductor temperature for which the tabulated current ratings have been calculated is 90 °C.

The reference ambient temperatures assumed are as follows:

- For cables in air: 40 °C
- For buried cables, either directly in the soil or in ducts in the ground: 30 °C

Derating factors for other ambient temperatures are given in Tables E.1 and E.2

The current ratings for cables in air do not take account of the increase, if any, due to solar or other infra-red radiation. Where the cables are subject to such radiation, the current rating should be derived by the methods specified in IEC 60287.

A.4 Soil thermal resistivity

The tabulated current ratings in this catalogue for cables in ducts or buried directly in the ground relate to a soil thermal resistivity of 1.5 °C.m/W. Information on the likely soil thermal resistivity in various countries is given in IEC 60287-3-1. Derating factors for other values of thermal resistivity are given in tables E.5 to E.8.

It is assumed that the soil properties are uniform; no allowance has been made for the possibility of moisture migration, which can lead to a region of high thermal resistivity around the cable. If partial drying-out of the soil is foreseen, the permissible current rating should be derived by the methods specified in IEC 60287.

A.5 Methods of installation

Current ratings are tabulated in this catalogue for cables installed in the following conditions.

A.5.1 Single-core cables in air

The cables are assumed to be spaced at least 0.5 times the cable diameter D_e from any vertical surface and installed on brackets or ladder racks as follows:

- a Three cables in trefoil formation touching throughout their length;
- b Three cables in horizontal flat formation touching throughout their length;
- c Three cables in horizontal flat formation with a clearance of one cable diameter.

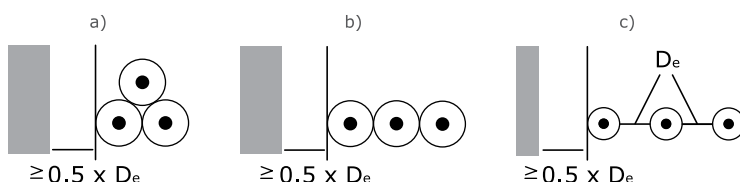

A.5.2 Single-core cables buried direct

Current ratings are given for cables buried direct in the ground at a depth of 0.8 m under the following conditions:

- Three cables in trefoil formation touching throughout their length;
- Three cables in horizontal flat formation with a clearance of one cable diameter, D_e .

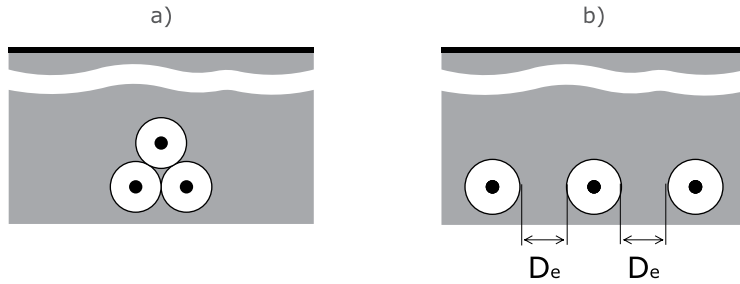

The cable depth is measured to the cable axis or center of the trefoil group.

A.5.3 Single-core cables in polyvinyl chloride (PVC) ducts

Current ratings are given for cables in polyvinyl chloride (PVC) ducts buried at a depth of 0.8 m with one cable per duct as follows:

- Three cables in trefoil ducts touching throughout their length;
- Three cables in ducts in horizontal flat formation, with ducts touching throughout their length

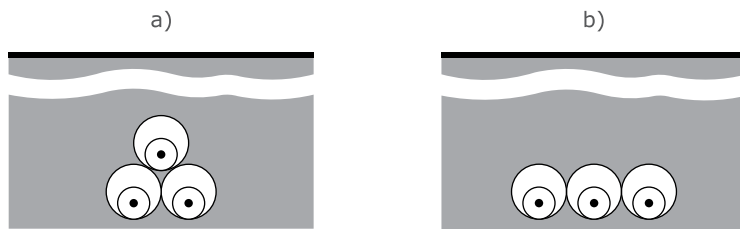

The ducts are assumed to be polyvinyl chloride (PVC) having an inside diameter of 1.5 times the outside diameter of the cable and a wall thickness equal to 6 % of the duct inside diameter. The ratings are based on the assumption that the ducts are air filled. If the ducts have been filled with a material such as Bentonite, then it is usual to adopt the current ratings for cables buried direct.

The tabulated ratings may be applied to cables in ducts having an inside diameter of between 1.2 and 2 times the outside diameter of the cables. For this range of diameters, the variation in the rating is less than 2 % of the tabulated value.

Annex A: Continuous Current Ratings

A.5.4 Three-core cables

Current ratings are given for three-core cables installed under the following conditions:

- Single cable in air spaced at least 0.3 times the cable diameter from any vertical surface;
- Single cable buried direct in the ground at a depth of 0.8 m;
- Single cable in a buried polyvinyl chloride (PVC) duct having dimensions calculated in the same manner as for the single-core cables in ducts. The depth of burial of the duct is 0.8 m.

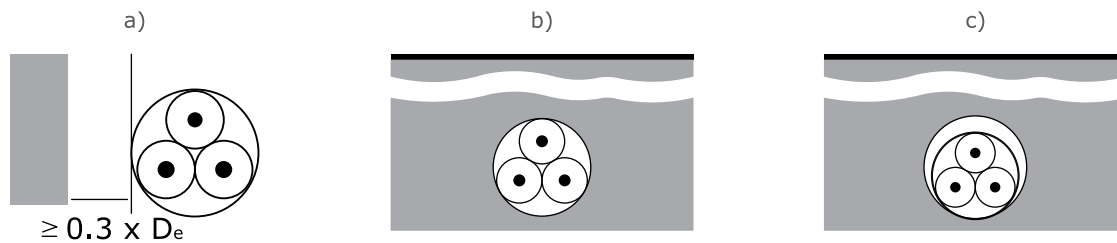

It has been assumed for cases b & c of A.5.1, and case b of A.5.2, in addition to cases a & b of A.5.3 that the cables are not transposed and the spacing between cables in horizontal flat formation is even.

A.6 Screen bonding

All the tabulated ratings for single-core or three-core cables assume that the cable screens are solidly bonded i.e. bonded at both ends of the cables.

A.7 Cable loading

The tabulated ratings relate to circuits carrying a balanced three-phase load at a rated frequency of 60 Hz. However, the tabulated ratings can be safely used with circuits carrying a balanced three-phase load at a rated frequency of 50 Hz, where the continuous current rating values are slightly higher in case of rated frequency of 50 Hz.

A.8 Rating factors for grouped circuits

The tabulated current ratings apply to a set of three single-core cables or one three-core cable forming a three-phase circuit. When a number of circuits are installed in close proximity, the rating should be reduced by the appropriate factor from tables E.9 to E.14.

These rating factors should also be applied to groups of parallel cables forming the same circuit. In such cases, attention should also be given to the arrangement of the cables to ensure that the load current is shared equally between the parallel cables.

A.9 Derating factors

The derating factors given in tables E.1 to E.14 for temperature, installation conditions and grouping are averages over a range of conductor sizes and cable types. For particular cases, the derating factor may be calculated using the methods in IEC 60287.

Annex B: Recommendations

Installation of Cables

B.1 Minimum installation radius

None of the medium voltage power cables should be bent during installation to a radius smaller than the following:

Single-core cables

- Unarmoured : 20 Ø
- Armoured : 15 Ø

Three-core cables

- Unarmoured : 15 Ø
- Armoured : 12 Ø

Where, Ø is the overall diameter of the cable.

Wherever possible, larger installation radius should be used, except that the minimum bending radius where the cables are placed in position adjacent to joints and terminations may be reduced to that given in the below table, provided that the bending is carefully controlled, e.g. by the use of a former.

Single-core cables

- Unarmoured : 15 Ø
- Armoured : 12 Ø

Three-core cables

- Unarmoured : 12 Ø
- Armoured : 10 Ø

B.2 Minimum temperature during installation

It is recommended that the cables should be installed only when both the cable and the ambient temperature are above 0 °C and have been so for the past 24 hours, or where special precautions have been taken to maintain the cable above this temperature.

B.3 Prevention of moisture ingress

Care should be exercised during installation to avoid any damage to cable coverings. This is important in wet or other hostile environments. The protective end cap should not be removed from the ends of the cable until immediately prior to termination or jointing, especially for cables that do not have extruded bedding. When the caps have been removed, the unprotected ends of the cable should not be exposed to moisture.

B.4 Maximum pulling tension

The maximum pulling tension is depending on the cable design, the mechanical limitations, the conductor material, and the method of laying and pulling the cables. The maximum permissible pulling force can be calculated based on the methods of pulling as follows:



Annex B: Recommendations

B.4.1 Pulling eye attached to the conductor

With pulling eye attached to copper conductors, the maximum pulling tension should not exceed 0.036 times the circular mil area of a conductor (Cm). With pulling eye attached to aluminum conductors, the maximum pulling tension should not exceed 0.027 times the circular mil area of conductor (Cm). Or in other words

$$T_m = 0.036 \times n \times C_m \quad (\text{Copper})$$

$$T_m = 0.027 \times n \times C_m \quad (\text{Aluminum})$$

Where;

T_m : Maximum pulling tension in N

n : The number of conductors

C_m : Circular mil area of each conductor

The maximum limitation for this calculation is **22240 N** (2268 kgf) for single conductor (1/C) cables, and **44480N** (4536 kgf) for multi-core cables. This limitation is due to unequal distribution of tension forces when pulling multiple conductors.

When the calculated pulling tension is close to (or within 10% of) the maximum pulling tension, the use of a tension gauge during the pulling is recommended.

B.4.2 Cable grip over lead sheath

With cable grip over lead sheath, with commercial lead, the maximum pulling tension on the lead sheath should not exceed **10.33 N/mm²** (1500 lbf/in²).

B.4.3 Cable grip over non-lead cable

With cable grip over non-lead cable, the maximum pulling tension should not exceed **4400 N** (1000 lbf).

B.5 Check list prior to pulling cable

- a . Be sure there is adequate clearance between duct or conduit diameter and cable diameter.
- b . Use adequate lubrication of the proper type to reduce friction in conduit and duct pulls.
- c . After installation, check to determine that end seals are still intact and have not been damaged to the point where water could enter. Apply suitable end seals to help protect against damage if the cable will be subjected to immersion or rain. This is particularly important if there will be a time lapse between the pulling operation and splicing and terminating.
- d . Be sure to check the maximum tension limits of the cable pulling accessories (cable grips, pulling eyes, swivels, pull rope, etc.). They should have a capacity equal to or greater than the tension limits that are required to pull the cable.

B.6 Sidewall pressure

One of the limitations to be considered in the installation of electrical cables is sidewall pressure. The sidewall pressure is the force exerted on the insulation and sheath of the cable at a bend point when the cable is under tension, and is normally the limiting factor in an installation where cable bends are involved. The sidewall pressure in general is expressed as the tension out of a bend expressed in newtons divided by the inside radius of the bend expressed in meters.

$$P = \left[\frac{T_o}{r} \right]$$

Where;

P : Sidewall pressure in N/m (lbf/ft)

T_o : Tension leaving the bend in N (lbf)

r : Inside radius of conduit in m (ft)

The normal maximum sidewall pressure per meter (feet) of radius is as given below. However, in order to minimize cable damage because of excessive sidewall pressure, the installer should check the proper recommendations for each type of cables to be installed.

Cable Type	Maximum sidewall pressure	
	(N/m)	(lbf/ft)
6 to 15 kV Power cables	7300	500
20 and 30 kV Power cables	4400	300
Armoured cables (all voltage grades)	4400	300

B.7 Laying methods

The best method of laying a cable depends on the type of cable and working conditions. The following are generally applied as the most common cable laying methods:

B.7.1 Direct in the ground

This method is shown in the figure below, and is employed in following cases;

1. Where road is narrow so the construction of conduit under the road is not permitted.
2. Where the number of cables is few and no future increase is expected.
3. Where the road digging is easy.

B.7.2 Underground tunnels or ducts

This method is shown in the figures below, and is employed in following cases;

1. It is the main underground transmission line where the number of cables is many or expected to be increased in near future.
2. Where there is hard pavement or where hard pavement will be constructed in future.
3. Where digging is difficult due to heavy traffic.

Annex B: Recommendations

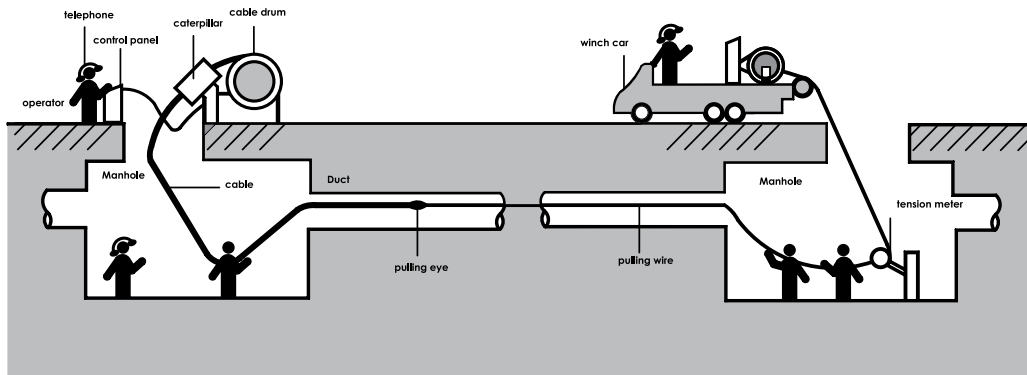
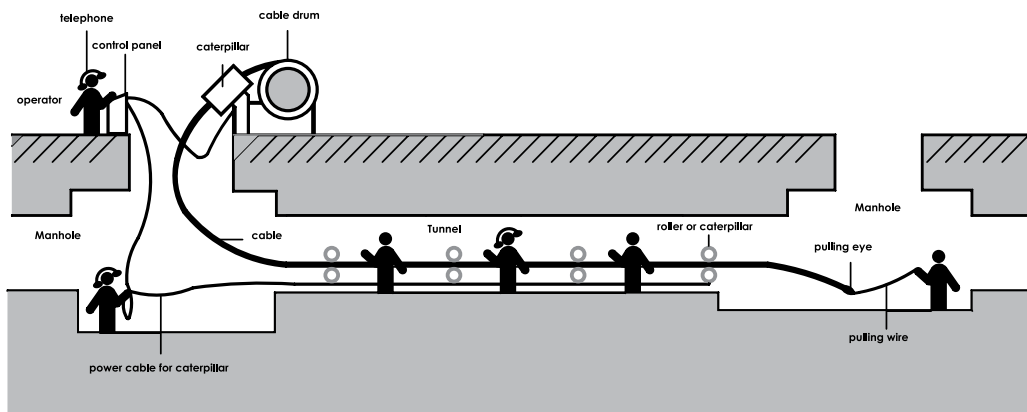
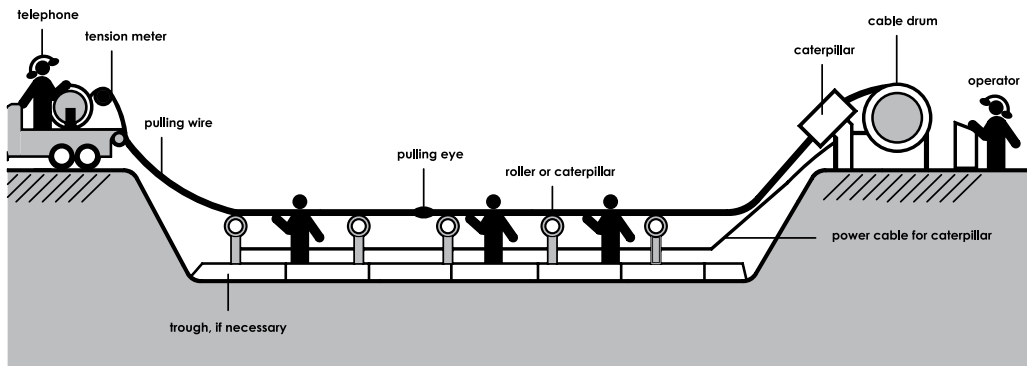

Annex C: Tests

C.1 Routine tests

Routine tests are normally carried out on each manufactured length of cable. The number of lengths to be tested may however be reduced or an alternative test method adopted, according to agreed quality control procedures.

The routine tests carried out in our manufacturing facilities are as follows:

- a . Measurement of the electrical resistance of conductors;
- b . Partial discharge test on cables having cores with conductor screens and insulation screens;
- c . Voltage test.



C.2 Sample tests

The sample tests carried out in our manufacturing facilities are as follows:

- a . Conductor examination;
- b . Check of dimensions;
- c . Voltage test for cables of rated voltage above 3.6 / 6 (7.2) kV;
- d . Hot set test for XLPE insulations and elastomeric sheaths.

C.3 Type tests

When type tests have been successfully performed on a type of cable covered by this catalogue with a specific conductor cross sectional area and rated voltage, type approval shall be accepted as valid for cables of the same type with other conductor cross-sectional areas and/or rated voltages, provided the following three conditions are all satisfied:

- a . The same materials, i.e. insulation and semi-conducting screens, and manufacturing process are used;
- b . The conductor cross-sectional area is not larger than that of the tested cable, with the exception that all cross-sectional areas up to and including 630 mm² are approved when the cross-sectional area of the previously tested cable is in the range of 95 mm² to 630 mm² inclusive;
- c . The rated voltage is not higher than that of the tested cable.

Approval shall be independent of the conductor material.

C.3.1 Sequence of tests

The normal sequence of tests shall be as follows:

- a . Bending test, followed by a partial discharge test;
- b . Tan δ measurement;
- c . Heating cycle test, followed by a partial discharge test;
- d . Impulse test, followed by a voltage test;
- e . Voltage test for 4 h.

Annex D: Formulas

D.1 Resistance

The values of conductor DC resistance given in the previous tables are based on 20 °C. In case the DC resistance is required at any other temperature the following formula is used:

$$R_{\theta} = R_{20} \times [1 + \alpha(\theta - 20)] \quad \Omega / \text{Km}$$

Where;

R_{θ}	Conductor DC resistance at θ °C	Ω / Km
R_{20}	Conductor DC resistance at 20 °C	Ω / Km
θ	Operating temperature	°C
α	Resistance temperature coefficient = 0.00393 for Copper = 0.00403 for Aluminum	$1 / ^\circ\text{C}$

To get the AC resistance of the conductor at its operating temperature the following formula is used:

$$R_{a.c} = R_{\theta} \times (1 + y_p + y_s) \quad \Omega / \text{Km}$$

Where

y_p and y_s are the proximity and skin effect factors, respectively, which depend on the laying and operating frequency of the cable.

D.2 Inductance

Self and mutual inductance are formulated as follows:

$$L = K + 0.2 \ln \left(\frac{2S}{d} \right) \quad \text{mH} / \text{Km}$$

Where;

L	Inductance	mH / Km
K	Constant depends on the conductors' number of wires	
d	Conductor diameter	mm
S	Axial spacing between cables = 1 x S in case of trefoil formation = 1.26 X S in case of flat formation	mm

D.3 Capacitance

$$C = \frac{\epsilon_r}{18 \ln \frac{D}{d}} \quad \mu\text{F} / \text{Km}$$

Where;

C	Capacitance	$\mu\text{F} / \text{Km}$
ϵ_r	Relative permittivity of insulation = 2.5 for XLPE insulation	
D	Diameter over insulation, excluding screen, if any	mm
d	Conductor diameter, including screen, if any	mm

D.4 Insulation Resistance

$$R = K \ln \left(\frac{D}{d} \right) \quad \text{M}\Omega / \text{Km}$$

Where;

R	Insulation resistance	$\text{M}\Omega / \text{Km}$
K	Constant depends on the insulation material	
d	Inner diameter of the insulation	mm
D	Outer diameter of the insulation	mm

D.5 Charging Current

The charging current is the capacitive current which flows when an AC voltage is applied to the cables as a result of the capacitance between the conductor and earth, and for a multi-core cable in which cores are not screened, between conductors.

The value can be derived from following the equation:

$$I_c = U_o \omega C 10^{-6} \quad \text{A} / \text{Km}$$

Where

I_c	Charging current	A / Km
U_o	Phase voltage	V
ω	$2 \pi f$	
f	Operating frequency	Hz
C	Capacitance to neutral	$\mu\text{F} / \text{Km}$

D.6 Dielectric Losses

The dielectric losses of an AC cable are proportional to the capacitance, the frequency, the phase voltage and the power factor. The value can be derived from the following equation:

$$W_d = \omega C U_o^2 \tan \delta 10^{-6} \quad \text{W} / \text{Km} / \text{Ph}$$

Where;

W_d	Dielectric Losses	$\text{W} / \text{Km} / \text{Ph}$
ω	$2 \pi f$	
f	Operating frequency	Hz
C	Capacitance to neutral	$\mu\text{F} / \text{Km}$
U_o	Phase voltage	V
$\tan \delta$	Dielectric power factor	

D.7 Short Circuit Capacity

Tables F.2 and F.3 give the short circuit current for conductor based on the following conditions:

- Short circuit starts from the maximum operating conductor temperature 90 °C
- Maximum temperature during short circuit 250 °C
- Maximum short circuit current duration is 5 seconds.

If the short circuit current is required at duration not mentioned in the catalogue, it is obtained by dividing the short circuit current for 1 second by the square root of the required duration as follows:

$$I_{s.c.t} = \frac{I_{s.c.1}}{\sqrt{t}}$$

Where;

$I_{s.c.t}$	Short circuit current for t second	<i>kA</i>
$I_{s.c.1}$	Short circuit current for 1 second	<i>kA</i>
t	Duration	<i>Sec.</i>

D.8 Voltage Drop

During current flows in a cable conductor there is a voltage drop between the ends of the conductors, which is the product of the current and the impedance. The following equations should be used to calculate the voltage drop of three-phase circuit:

$$V_d = \sqrt{3} I \ell (R \cos \Phi + X \sin \Phi) \quad V$$

Where

V_d	Voltage drop	<i>V</i>
I	Load current	<i>A</i>
ℓ	Route length	<i>km</i>
R	AC Resistance	Ω / Km
X	Reactance	Ω / Km
$\cos \Phi$	Power factor	

Where

$$X = \omega L 10^{-3} \quad \Omega / \text{Km}$$

Where

ω	$2 \pi f$	
f	Operating frequency	<i>Hz</i>
L	inductance	<i>mH/Km</i>

Relation between Cos θ and Sin θ :

cos Φ	1.0	0.9	0.85	0.8	0.6
sin Φ	1.0	0.44	0.53	0.6	0.8

Annex E: Derating Factors

Table E.1

Derating factors for ambient ground temperature

Max. Conductor temperature °C	Ambient ground temperature °C						
	20	25	30	35	40	45	50
90 °C	1.09	1.04	1.00	0.95	0.90	0.85	0.80

Table E.2

Derating factors for ambient air temperature

Max. Conductor temperature °C	Ambient air temperature °C						
	25	30	35	40	45	50	55
90 °C	1.14	1.10	1.05	1.00	0.95	0.89	0.84

Table E.3

Derating factors for depths of laying for direct buried cables

Depth of laying mt.	Single-core cables		Three-core cables
	Nominal conductor size		
	≤ 185 mm ²	> 185 mm ²	
0.50	1.04	1.06	1.04
0.60	1.02	1.04	1.03
0.80	1.00	1.00	1.00
1.00	0.98	0.97	0.98
1.25	0.96	0.95	0.96
1.50	0.95	0.93	0.95
1.75	0.94	0.91	0.94
2.00	0.93	0.90	0.93
2.50	0.91	0.88	0.91
3.00	0.90	0.86	0.90

Table E.4

Derating factors for depths of laying for cables in ducts

Depth of laying mt.	Single-core cables		Three-core cables
	Nominal conductor size		
	≤ 185 mm ²	> 185 mm ²	
0.50	1.04	1.05	1.03
0.60	1.02	1.03	1.02
0.80	1.00	1.00	1.00
1.00	0.98	0.97	0.99
1.25	0.96	0.95	0.97
1.50	0.95	0.93	0.96
1.75	0.94	0.92	0.95
2.00	0.93	0.91	0.94
2.50	0.91	0.89	0.93
3.00	0.90	0.88	0.92

Table E.5

Derating factors for soil thermal resistivities for direct buried single-core cables

Nominal area of conductor mm ²	Values of soil thermal resistivity °C.m / Watt							
	0.7	0.8	0.9	1.0	1.5	2.0	2.5	3.0
25	1.30	1.25	1.20	1.16	1.00	0.89	0.81	0.75
35	1.30	1.25	1.21	1.16	1.00	0.89	0.81	0.75
50	1.32	1.26	1.21	1.16	1.00	0.89	0.81	0.74
70	1.33	1.27	1.22	1.17	1.00	0.89	0.81	0.74
95	1.34	1.28	1.22	1.18	1.00	0.89	0.80	0.74
120	1.34	1.28	1.22	1.18	1.00	0.88	0.80	0.74
150	1.35	1.28	1.23	1.18	1.00	0.88	0.80	0.74
185	1.35	1.29	1.23	1.18	1.00	0.88	0.80	0.74
240	1.36	1.29	1.23	1.18	1.00	0.88	0.80	0.73
300	1.36	1.30	1.24	1.19	1.00	0.88	0.80	0.73
400	1.37	1.30	1.24	1.19	1.00	0.88	0.79	0.73
500	1.37	1.30	1.24	1.19	1.00	0.88	0.79	0.73
630	1.37	1.30	1.24	1.19	1.00	0.88	0.79	0.73
800	1.37	1.30	1.24	1.19	1.00	0.88	0.79	0.73
1000	1.37	1.30	1.24	1.19	1.00	0.88	0.79	0.73

Annex E: Derating Factors

Table E.6

Derating factors for soil thermal resistivities for single-core cables in buried ducts

Nominal area of conductor mm ²	Values of soil thermal resistivity °C.m / Watt							
	0.7	0.8	0.9	1.0	1.5	2.0	2.5	3.0
25	1.21	1.17	1.14	1.12	1.00	0.91	0.85	0.79
35	1.21	1.18	1.15	1.12	1.00	0.91	0.84	0.79
50	1.21	1.18	1.15	1.12	1.00	0.91	0.84	0.78
70	1.22	1.19	1.15	1.12	1.00	0.91	0.84	0.78
95	1.23	1.19	1.16	1.13	1.00	0.91	0.84	0.78
120	1.23	1.20	1.16	1.13	1.00	0.91	0.84	0.78
150	1.24	1.20	1.16	1.13	1.00	0.91	0.83	0.78
185	1.24	1.20	1.17	1.13	1.00	0.91	0.83	0.78
240	1.25	1.21	1.17	1.14	1.00	0.90	0.83	0.77
300	1.25	1.21	1.17	1.14	1.00	0.90	0.83	0.77
400	1.25	1.21	1.17	1.14	1.00	0.90	0.83	0.77
500	1.25	1.21	1.17	1.14	1.00	0.90	0.83	0.77
630	1.25	1.21	1.17	1.14	1.00	0.90	0.83	0.77
800	1.25	1.21	1.17	1.14	1.00	0.90	0.83	0.77
1000	1.25	1.21	1.17	1.14	1.00	0.90	0.83	0.77

Table E.7

Derating factors for soil thermal resistivities for direct buried three-core cables

Nominal area of conductor mm ²	Values of soil thermal resistivity °C.m / Watt							
	0.7	0.8	0.9	1.0	1.5	2.0	2.5	3.0
25	1.24	1.20	1.16	1.13	1.00	0.91	0.84	0.78
35	1.25	1.21	1.17	1.13	1.00	0.91	0.83	0.78
50	1.25	1.21	1.17	1.14	1.00	0.91	0.83	0.77
70	1.26	1.21	1.18	1.14	1.00	0.90	0.83	0.77
95	1.26	1.22	1.18	1.14	1.00	0.90	0.83	0.77
120	1.26	1.22	1.18	1.14	1.00	0.90	0.83	0.77
150	1.27	1.22	1.18	1.15	1.00	0.90	0.83	0.77
185	1.27	1.23	1.18	1.15	1.00	0.90	0.83	0.77
240	1.28	1.23	1.19	1.15	1.00	0.90	0.83	0.77
300	1.28	1.23	1.19	1.15	1.00	0.90	0.82	0.77
400	1.28	1.23	1.19	1.15	1.00	0.90	0.82	0.76

Table E.8

Derating factors for soil thermal resistivities for three-core cables in buried ducts

Nominal area of conductor mm ²	Values of soil thermal resistivity °C.m / Watt							
	0.7	0.8	0.9	1.0	1.5	2.0	2.5	3.0
25	1.14	1.12	1.10	1.08	1.00	0.94	0.89	0.84
35	1.14	1.12	1.10	1.08	1.00	0.94	0.88	0.84
50	1.14	1.12	1.10	1.08	1.00	0.94	0.88	0.84
70	1.15	1.13	1.11	1.09	1.00	0.94	0.88	0.83
95	1.15	1.13	1.11	1.09	1.00	0.94	0.88	0.83
120	1.15	1.13	1.11	1.09	1.00	0.93	0.88	0.83
150	1.16	1.13	1.11	1.09	1.00	0.93	0.88	0.83
185	1.16	1.14	1.11	1.09	1.00	0.93	0.87	0.83
240	1.16	1.14	1.12	1.10	1.00	0.93	0.87	0.82
300	1.17	1.14	1.12	1.10	1.00	0.93	0.87	0.82
400	1.17	1.14	1.12	1.10	1.00	0.92	0.86	0.81

Table E.9

Derating factors for groups of three-core cables in horizontal formation laid direct in the ground

Number of cables in group	Spacing between cable centers				
	Touching	200 mm	400 mm	600 mm	800 mm
2	0.80	0.86	0.90	0.92	0.94
3	0.69	0.77	0.82	0.86	0.89
4	0.62	0.72	0.79	0.83	0.87
5	0.57	0.68	0.76	0.81	0.85
6	0.54	0.65	0.74	0.80	0.84
7	0.51	0.63	0.72	0.78	0.83
8	0.49	0.61	0.71	0.78	-
9	0.47	0.60	0.70	0.77	-
10	0.46	0.59	0.69	-	-
11	0.45	0.57	0.69	-	-
12	0.43	0.56	0.68	-	-

Annex E: Derating Factors

Table E.10

Derating factors for groups of three-phase circuits of single-core cables laid direct in the ground

Number of cables in group	Spacing between group centers				
	Touching	200 mm	400 mm	600 mm	800 mm
2	0.73	0.83	0.88	0.90	0.92
3	0.60	0.73	0.79	0.83	0.86
4	0.54	0.68	0.75	0.80	0.84
5	0.49	0.63	0.72	0.78	0.82
6	0.46	0.61	0.70	0.76	0.81
7	0.43	0.58	0.68	0.75	0.80
8	0.41	0.57	0.67	0.74	-
9	0.39	0.55	0.66	0.73	-
10	0.37	0.54	0.65	-	-
11	0.36	0.53	0.64	-	-
12	0.35	0.52	0.64	-	-

Table E.11

Derating factors for groups of three-core cables in single-way ducts in horizontal formation

Number of cables in group	Spacing between duct centers				
	Touching	200 mm	400 mm	600 mm	800 mm
2	0.85	0.88	0.92	0.94	0.95
3	0.75	0.80	0.85	0.88	0.91
4	0.69	0.75	0.82	0.86	0.89
5	0.65	0.72	0.79	0.84	0.87
6	0.62	0.69	0.77	0.83	0.87
7	0.59	0.67	0.76	0.82	0.86
8	0.57	0.65	0.75	0.81	-
9	0.55	0.64	0.74	0.80	-
10	0.54	0.63	0.73	-	-
11	0.52	0.62	0.73	-	-
12	0.51	0.61	0.72	-	-

Table E.12

Derating factors for groups of three-phase circuits of single-core cables in single-way ducts

Number of cables in group	Spacing between group centers				
	Touching	200 mm	400 mm	600 mm	800 mm
2	0.78	0.85	0.89	0.91	0.93
3	0.66	0.75	0.81	0.85	0.88
4	0.59	0.70	0.77	0.82	0.86
5	0.55	0.66	0.74	0.80	0.84
6	0.51	0.64	0.72	0.78	0.83
7	0.48	0.61	0.71	0.77	0.82
8	0.46	0.60	0.70	0.76	-
9	0.44	0.58	0.69	0.76	-
10	0.43	0.57	0.68	-	-
11	0.42	0.56	0.67	-	-
12	0.40	0.55	0.67	-	-

Table E.13

Derating factors for groups of more than one three-core cable in air

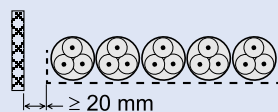
Cables on horizontal perforated trays (touching)							Laying form
Clearance from the wall ≥ 20 mm	Number of cables (three-phase circuits)						
Number of trays	1	2	3	4	6	9	
1	1.00	0.88	0.82	0.79	0.76	0.73	
2	1.00	0.87	0.80	0.77	0.73	0.68	
3	1.00	0.86	0.79	0.76	0.71	0.66	

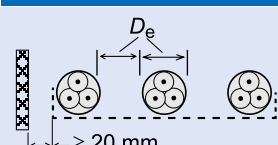
Cables on horizontal perforated trays (spaced)							Laying form
Clearance = cable diameter (D_e) Clearance from the wall ≥ 20 mm	Number of cables (three-phase circuits)						
Number of trays	1	2	3	4	6	9	
1	1.00	1.00	0.98	0.95	0.91	-	
2	1.00	0.99	0.96	0.92	0.87	-	
3	1.00	0.98	0.95	0.91	0.85	-	

Annex E: Derating Factors

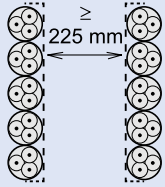
Cables on vertical perforated trays (touching)							Laying form 
Clearance betw. trays ≥ 225 mm	Number of cables (three-phase circuits)						
Number of trays	1	2	3	4	6	9	
1	1.00	0.88	0.82	0.78	0.73	0.72	
2	1.00	0.88	0.81	0.76	0.71	0.70	
3	-	-	-	-	-	-	

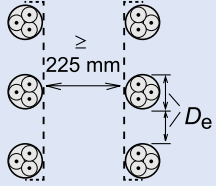
Cables on vertical perforated trays (spaced)							Laying form 
Clearance = cable diameter (D _e) Clearance betw. trays ≥ 225 mm	Number of cables (three-phase circuits)						
Number of trays	1	2	3	4	6	9	
1	1.00	0.87	0.82	0.80	0.79	0.78	
2	1.00	0.86	0.80	0.78	0.76	0.73	
3	1.00	0.85	0.79	0.76	0.73	0.70	

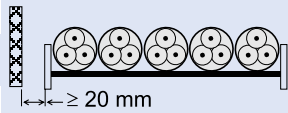
Cables on ladder supported, cleats, etc. (touching)							Laying form 
Clearance from the wall ≥ 20 mm	Number of cables (three-phase circuits)						
Number of trays	1	2	3	4	6	9	
1	1.00	0.91	0.89	0.88	0.87	-	
2	1.00	0.91	0.88	0.87	0.85	-	
3	-	-	-	-	-	-	

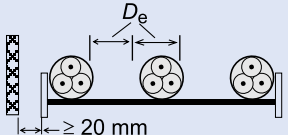
Cables on ladder supported, cleats, etc. (spaced)							Laying form 
Clearance = cable diameter (D _e) Clearance from the wall ≥ 20 mm	Number of cables (three-phase circuits)						
Number of trays	1	2	3	4	6	9	
1	1.00	1.00	1.00	1.00	1.00	-	
2	1.00	0.99	0.98	0.97	0.96	-	
3	1.00	0.98	0.97	0.96	0.93	-	

NOTES:

1. Values given have to be applied to the current carrying capacity for one three-core cable in free air.
2. Values given are averages for the cable types and range of conductor sizes considered. The spread of values is generally less than 5 %.
3. Factors apply to single layer groups of cables as shown above and do not apply when cables are installed in more than one layer touching each other. Values for such installations may be significantly lower and must be determined by an appropriate method.
4. Values are given for vertical spacing between trays of 300 mm and at least 20 mm between trays and wall. For closer spacing, the factors should be reduced.
5. Values are given for horizontal spacing between trays of 225 mm with trays mounted back to back. For closer spacing, the factors should be reduced.

Table E.14

Derating factors for groups of more than one circuit of single-core cables

Cables on horizontal perforated trays (touching)				Laying form 
Clearance from the wall ≥ 20 mm	Number of three-phase circuits			
Number of trays	1	2	3	
1	0.98	0.91	0.87	
2	0.96	0.87	0.81	
3	0.95	0.85	0.78	

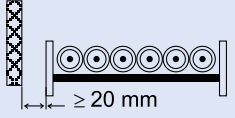
Cables on ladder supported, cleats, etc. (touching)				Laying form 
Clearance from the wall ≥ 20 mm	Number of three-phase circuits			
Number of trays	1	2	3	
1	1.00	0.97	0.96	
2	0.98	0.93	0.89	
3	0.97	0.90	0.86	

Annex E: Derating Factors

Cables on horizontal perforated trays (spaced)				Laying form
Clearance = 2 cable diameter (D_e) Clearance from the wall ≥ 20 mm	Number of three-phase circuits			
Number of trays	1	2	3	
1	1.00	0.98	0.96	
2	0.97	0.93	0.89	
3	0.96	0.92	0.86	

Cables on vertical perforated trays (spaced)				Laying form
Clearance = 2 cable diameter (D_e) Clearance betw. trays ≥ 225 mm	Number of three-phase circuits			
Number of trays	1	2	3	
1	1.00	0.91	0.89	
2	1.00	0.90	0.86	
3	-	-	-	

Cables on ladder supported, cleats, etc. (spaced)				Laying form
Clearance = 2 cable diameter (D_e) Clearance from the wall ≥ 20 mm	Number of three-phase circuits			
Number of trays	1	2	3	
1	1.00	1.00	1.00	
2	0.97	0.95	0.93	
3	0.96	0.94	0.90	

NOTES:

1. Values given have to be applied to the current carrying capacity for one three-phase circuit of single-core cables in free air, either in trefoil or horizontal (flat) formation.
2. Values given are averages for the cable types and range of conductor sizes considered. The spread of values is generally less than 5 %.
3. Factors are given for single layer of cables (or trefoil groups) as shown in the table and do not apply when cables are installed in more than one layer touching each other. Values for such installations may be significantly lower and should be determined by an appropriate method.
4. Values are given for vertical spacing between trays of 300 mm. For closer spacing, the factors should be reduced.
5. Values are given for horizontal spacing between trays of 225 mm with trays mounted back to back. For closer spacing, the factors should be reduced.
6. For circuits having more than one cable in parallel per phase, each three phase set of conductors should be considered as a circuit for the purpose of this table.

Annex F: Short Circuit Current

Table F.1

Max. short circuit temperature for cable components

Material	Cable component	Max. short circuit temp. °C
Conductor	Copper or aluminum	250 *
Insulation	XLPE Insulation	250
Sheathing	PVC Sheath	200
	LDPE Sheath	150
	HDPE Sheath	180
	Lead Sheath	170
	Lead Alloy Sheath	210

Table F.2

kA Short circuit current - Copper conductor - XLPE Insulated

C.S.A mm ²	Short circuit duration sec.									
	0.1	0.2	0.3	0.4	0.5	1.0	2.0	3.0	4.0	5.0
25	11.3	8.0	6.5	5.7	5.1	3.6	2.5	2.1	1.8	1.6
35	15.8	11.2	9.1	7.9	7.1	5.0	3.5	2.9	2.5	2.2
50	22.6	16.0	13.1	11.3	10.1	7.2	5.1	4.1	3.6	3.2
70	31.7	22.4	18.3	15.8	14.2	10.0	7.1	5.8	5.0	4.5
95	43.0	30.4	24.8	21.5	19.2	13.6	9.6	7.8	6.8	6.1
120	54.3	38.4	31.3	27.1	24.3	17.2	12.1	9.9	8.6	7.7
150	67.9	48.0	39.2	33.9	30.4	21.5	15.2	12.4	10.7	9.6
185	83.7	59.2	48.3	41.9	37.4	26.5	18.7	15.3	13.2	11.8
240	108.6	76.8	62.7	54.3	48.6	34.3	24.3	19.8	17.2	15.4
300	135.7	96.0	78.4	67.9	60.7	42.9	30.4	24.8	21.5	19.2
400	181.0	128.0	104.5	90.5	80.9	57.2	40.5	33.0	28.6	25.6
500	226.2	160.0	130.6	113.1	101.2	71.5	50.6	41.3	35.8	32.0
630	285.1	201.6	164.6	142.5	127.5	90.1	63.7	52.0	45.1	40.3
800	362.0	256.0	209.0	181.0	161.9	114.5	80.9	66.1	57.2	51.2
1000	452.5	319.9	261.2	226.2	202.4	143.1	101.2	82.6	71.5	64.0
1200	543.0	383.9	313.5	271.5	242.8	171.7	121.4	99.1	85.9	76.8
1400	633.5	447.9	365.7	316.7	283.3	200.3	141.6	115.7	100.2	89.6
1600	724.0	511.9	418.0	362.0	323.8	228.9	161.9	132.2	114.5	102.4
1800	814.4	575.9	470.2	407.2	364.2	257.6	182.1	148.7	128.8	115.2
2000	904.9	639.9	522.5	452.5	404.7	286.2	202.4	165.2	143.1	128.0
2500	1131.2	799.9	653.1	565.6	505.9	357.7	252.9	206.5	178.9	160.0

Annex F: Short Circuit Current

Table F.3

kA Short circuit current - Aluminum conductor - XLPE Insulated

C.S.A	Short circuit duration sec.									
mm ²	0.1	0.2	0.3	0.4	0.5	1.0	2.0	3.0	4.0	5.0
25	7.5	5.3	4.3	3.7	3.3	2.4	1.7	1.4	1.2	1.1
35	10.5	7.4	6.0	5.2	4.7	3.3	2.3	1.9	1.7	1.5
50	14.9	10.6	8.6	7.5	6.7	4.7	3.3	2.7	2.4	2.1
70	20.9	14.8	12.1	10.5	9.4	6.6	4.7	3.8	3.3	3.0
95	28.4	20.1	16.4	14.2	12.7	9.0	6.3	5.2	4.5	4.0
120	35.9	25.4	20.7	17.9	16.0	11.3	8.0	6.5	5.7	5.1
150	44.8	31.7	25.9	22.4	20.0	14.2	10.0	8.2	7.1	6.3
185	55.3	39.1	31.9	27.6	24.7	17.5	12.4	10.1	8.7	7.8
240	71.7	50.7	41.4	35.9	32.1	22.7	16.0	13.1	11.3	10.1
300	89.6	63.4	51.8	44.8	40.1	28.3	20.0	16.4	14.2	12.7
400	119.5	84.5	69.0	59.8	53.4	37.8	26.7	21.8	18.9	16.9
500	149.4	105.6	86.3	74.7	66.8	47.2	33.4	27.3	23.6	21.1
630	188.2	133.1	108.7	94.1	84.2	59.5	42.1	34.4	29.8	26.6
800	239.0	169.0	138.0	119.5	106.9	75.6	53.4	43.6	37.8	33.8
1000	298.8	211.3	172.5	149.4	133.6	94.5	66.8	54.6	47.2	42.3
1200	358.5	253.5	207.0	179.3	160.3	113.4	80.2	65.5	56.7	50.7
1400	418.3	295.8	241.5	209.1	187.1	132.3	93.5	76.4	66.1	59.2
1600	478.1	338.0	276.0	239.0	213.8	151.2	106.9	87.3	75.6	67.6
1800	537.8	380.3	310.5	268.9	240.5	170.1	120.3	98.2	85.0	76.1
2000	597.6	422.5	345.0	298.8	267.2	189.0	133.6	109.1	94.5	84.5
2500	747.0	528.2	431.3	373.5	334.1	236.2	167.0	136.4	118.1	105.6

NOTES:

1. The short circuit current ratings given in tables F.2 and F.3 are calculated in accordance with IEC 60949 and are the symmetrical currents which will cause the conductor temperature to rise from the normal operating value of 90 °C to the maximum short circuit temperature of 250 °C in the time stated, assuming adiabatic conditions (i.e. neglecting heat loss).
2. The screen short circuit current ratings (when required), will be calculated in accordance with IEC 60949 and they are the asymmetrical currents which will cause the screen temperature to rise from the normal operating value of 80 °C to the maximum short circuit temperature, assuming adiabatic conditions. The final temperature used in the calculation varies depending upon the nature of the screen material itself and also on the other materials in direct contact with the screen. The screen short circuit current ratings can also be calculated in accordance with ICEA P-45482-. The screen constructions detailed in this catalogue represent our standard design, but its size and type can be tailored to meet specific fault requirements of any operating system.

Annex G: Materials Properties

Metals Used For Cables

Table .G1

Electrical Properties			
Metal	Relative Conductivity Copper 100	Electrical Resistivity at 20 °C $\Omega.m(10^{-8})$	Temperature Coefficient of Resistance per °C
Copper (Annealed)	100	1.7241	0.00393
Copper (Hard drawn)	97	1.7770	0.00393
Tinned Copper	9597-	1.741- 1.814	0.00393
Aluminum	61	2.8264	0.00403
Lead	8	21.40	0.00400

Physical Properties				
Property	Unit	Copper	Aluminum	Lead
Density at 20 °C	Kg/m ³	8890.0	2703.0	11340.0
Coeff. of thermal expansion	°C x 10 ⁶ -	17.0	23.0	29.0
Melting point	°C	1083.0	659.0	327.0
Thermal conductivity	W/Cm.°C	3.8	2.4	0.34

Insulation Materials Used For Cables

Table .G2

Properties		XLPE	EPR
Rated Temp.	Nominal	90	90
	Emergency	130	130
	Short Circuit	250	250
Mechanical Strength	Min. Tensile Strength (N/mm ²)	12.5	4.2
	Min. Elongation %	200	200
Heat deformation at 150 °C		Good	Excellent
Relative permittivity		2.5	3.0
Specific gravity g/cm ³		0.93	1.4
Solvent resistance		Good	Poor
Volume Resistivity at max. conductor temperature in normal operation	$\Omega.cm$	10^{12}	1012
Splicing & termination		Easy	Easy
Environmental stress cracking		Good	Poor

Annex H: Coding Key

1 2 3 4 5 6 7 8 9 10 11 12 13 14 15 16 17 18

The type designation provides information on the type of cable, the conductor material, the insulation and sheath materials, the no. of cores, and the principle design features in abbreviated and simplified form.

The type designation is made up of 18 digits or characters. The type of the conductor is specified first and then the cable construction from inside to outside.

You can order our product either by giving the Cable code stated in the catalogue or if the required cable construction is not included in our catalogue, you can use the following codes to determine the type of cable you require.

1. Type of conductor material

C	Copper
A	Aluminum

2. Type of conductor

3	Circular compacted conductor
7	Milliken conductor
8	Circular compacted - WTD *
9	Milliken conductor - WTD *

3 & 4. Size of conductor

16	25 mm ²
17	35 mm ²
18	50 mm ²
19	70 mm ²
45	95 mm ²
46	120 mm ²
47	150 mm ²
48	185 mm ²
49	240 mm ²
50	300 mm ²
51	400 mm ²
52	500 mm ²
53	630 mm ²
54	800 mm ²
55	1000 mm ²
56	1200 mm ²
57	1400 mm ²
58	1600 mm ²
59	1800 mm ²
60	2000 mm ²
61	2500 mm ²
62	3000 mm ²

5. Type of insulation material

X	XLPE Insulation
---	-----------------

T	XLPE - Tree retardant
---	-----------------------

6. Voltage grade (U₀ / U)

F	3.6 / 6 kV
G	3.8 / 6.6 kV
H	6 / 10 kV
I	6.35 / 11 kV
J	8.7 / 15 kV
K	12 / 20 kV
L	12.7 / 22 kV
M	18 / 30 kV
N	19 / 33 kV
O	20 / 35 kV

7. Number of cores

1	Single-core
3	Three-core

8. Insulation screen material type

B	Bonded type
S	Strippable type

9. Metallic screen type

A	Copper wires
B	Copper tape
C	Lead alloy
D	Copper wires + Copper tape
E	Copper wires + Lead alloy
F	Copper wires + PE/AL/PE foil
G	Copper wires + Copper foil

10. Armouring

0	Without armouring
L	Pure lead sheathed
N	Lead alloy sheathed
A	Aluminum wire armoured
B	Aluminum tape armoured
W	Galvanized steel wire armoured
G	Galvanized steel tape armoured
T	Non-Galva. Steel tape armoured
S	Lead + G. Steel tape armoured
D	Lead + G. Steel wire armoured
X	Lead + Aluminum wire armoured
R	Lead + Aluminum tape armoured

11. Outer sheath material

M	PVC Sheath
L	LSHF Sheath
R	PVC - F.R to IEC 6033224-3- (C)
X	PVC - F.R to IEC 6033222-3- (A)

E	LDPE
D	MDPE
G	HDPE
I	LMDPE
B	LLDPE

12. Outer sheath color

R	Red
B	Black
Y	Yellow
L	Blue
O	Orange

13&14. Metallic screen earth fault current

XX	Standard
01	1 kA for 1 sec.
02	2 kA for 1 sec.
03	3 kA for 1 sec.
:	:
99	99 kA for 1 sec.

15. Design standard

I	IEC Standard
B	BS Standard
E	AEIC / ICEA Standard
C	Customer request

16. Customer

0	Standard
S	Saudi Electricity Company SDMS
T	Saudi Electricity Company TMSS
A	Saudi Aramco 15-SAMSS-502
B	SABIC E22-S02

17. Packing type

M	Wooden drum
T	Steel drum

18. Cutting length (Note 1)

S	250 Meter
T	300 Meter
V	350 Meter
U	400 Meter
X	450 Meter
F	500 Meter
R	1000 Meter

Note 1: The mentioned cutting lengths are the most common. However, any other cutting lengths can be supplied as per a customer's drum schedule.

Annex I: Information and Agreements

I.1 Requisite Information with Enquiry and/or Order

- a. Length of cable required, and individual drum lengths, if particular drum lengths are required;
- b. Voltage designation;
- c. Number of cores;
- d. Size of phase conductor;
- e. Conductor material (i.e. copper or aluminum);
- f. Type of insulation and limiting dimensions (if any) of the cores;
- g. Type of insulation screen (i.e. bonded or cold strippable);
- h. Type of metallic screen (i.e. copper wires or copper tape(s) or a combination of wires and tape(s);
- i. Cross-sectional area of metallic screen and/or earth fault current;
- j. If an armour layer for single-core cable with a special construction is required which requires the armour to be made of magnetic material;
- k. If a steel armour layer for three-core cable with a specific minimum conductance is required;
- l. Type of outer jacket (i.e. PVC or PE or LSHF);
- m. If a d.c. voltage test on the outer jacket is required.

I.2 Agreements

The following items shall be agreed between the customer and us at the time of enquiry and/or order:

- a. Colour of the outer jacket if a colour other than red is required;
- b. Sampling frequency for sample tests if different from that specified by the design standard.

Annex J: Conversion Table

Multiply	By	To Obtain	Multiply	By	To Obtain
Weight-Imperial					
Ounces	28.3495	Grams	Inches	1000	Mils
Pounds(Av)	453.59	Grams	Inches	25.40	mm
Pounds(Av)	0.45359	Kilograms	Inches	2.54	cm
Tons (short)	907.19	Kilograms	Feet	30.48	cm
Tons (long)	1016.05	Kilograms	Feet	0.3048	Meters
			Feet (thousand of)	0.3048	Kilometers
			Yards	0.9144	Meters
			Miles	1.6093	Kilometers
Weight-Metric					
Grams	0.03527	Ounces	Length-Metric		
Grams	0.002205	Pounds	Millimeters	39.37	Mils
Kilograms	35.274	Ounces	Millimeters	0.03937	Inches
Kilograms	2.2046	Pounds	Centimeters	0.3937	Inches
kilograms	0.001102	Tons (short)	Centimeters	0.032808	Feet
Kilograms	0.0009842	Tons (long)	Meters	39.37	Inches
			Meters	3.2808	Feet
			Meters	1.0936	Yards
			Kilometers	3280.83	Feet
			Kilometers	0.62137	Miles
Miscellaneous-Imperial					
Pounds per 1000 feet	1.48816	Kg/km	Area Imperial		
Pounds per mile	0.28185	Kg/km	Square mils	1.2732	Circular mils
Pounds per square inch	0.0007031	Kg. per square mm	Square mils	0.000001	Square inches
Pounds per square inch	0.07031	Kg. per square cm	Circular mils	0.7854	Square mils
Pounds per cubic inch	27.68	Grams per cubic cm	Circular mils	0.000007854	Square inches
Feet per second	18.288	Meters per minute	Square mils	0.0005067	Square mm
Feet per second	1.09728	Kilometers per hour	Square inches	1000000	Square mils
Miles per hour	1.60935	Kilometers per hour	Square inches	1273240	Circular mils
Ohms per 1000 feet	3.28083	Ohms per Kilometer	Square inches	645.16	Square mm
Ohms per mile	0.62137	Ohms per Kilometer	Square inches	6.4516	Square cm
Decibels per 1000 feet	3.28083	Decibels per kilometer	Square feet	0.09290	Square meters
Decibels per mile	0.62137	Decibels per kilometer	Square yards	0.8361	Square meters
Decibels	0.1153	neper	Area Metric		
Miscellaneous-Metric					
Kg/km	0.67197	Pounds per 1000 feet	Square millimeters	1973.52	Circular mils
Kg/km	3.54795	Pounds per mile	Square millimeters	0.00155	Square inches
Kg. per square mm	1422.34	Pounds per square inch	Square centimeters	0.155	Square inches
Kg. per square cm	14.2234	Pounds per square inch	Square meters	10.7639	Square feet
Grams per cubic cm	0.03613	Pounds per cubic inch	Square meters	1.19599	Square yard
Meters per minute	0.05468	Feet per second	Volume Imperial		
Kilometers per hour	0.91134	Feet per second	Cubic inches	16.38706	Cubic cm
Kilometers per hour	0.62137	Miles per hour	Cubic feet	0.028317	Cubic meters
Ohms per Kilometer	0.3048	Ohms per 1000 feet	Gallons	4.54609	Liters
Ohms per Kilometer	1.6093	Ohms per mile	Volume U.S.		
Decibels per kilometer	0.3048	Decibels per 1000 feet	Quarts (liquid)	0.9463	Liters
Decibels per kilometer	1.6093	Decibels per mile	Gallons	3.7854	Liters
Temperature					
° Fahrenheit	59/(°F)-32	°Celsius	Volume Metric		
°Celsius	95/(°C)+32	° Fahrenheit	Cubic cm	0.06102	Cubic inches
			Cubic meters	35.3145	Cubic feet
			Liters	1.05668	Quarts (liquid U.S)
			Liters	0.26417	Gallons (U.S.)
Length-Imperial					
Mils	0.001	inches			
Mils	0.0254	mm			

Product Range

alfanar manufactures a wide range of low, medium and high voltage electrical products under 50 categories. Listed below is **alfanar**'s comprehensive product classification:

POWER & CONTROL

Low Voltage Products

- Load Center
- Circuit Breaker Enclosures
- Busbar Chamber
- Breakers



Low Voltage Systems

- Switch Boards – MF Type
- Distribution Boards – MB Type
- Motor Control Centres
- Capacitor Banks – Power Factor Correction Panels
- Automatic Transfer Switch (ATS Panels)
- Distribution Boards for Substations
- Synchronizing Panels
- Control & Automation Panels



Package & Unit Substations

- Indoor Package Substation
- Outdoor Package Substation
- Indoor Unit Substation
- Outdoor Unit Substation



Medium Voltage Systems

- Switchgear (Metal clad, Metal enclosed)
- Control gear
- Ring Main Unit (RMU)
- Retrofit solution



METAL ENCLOSURES

- Metal Enclosures IP65
- Modular Enclosures
- Extendable Cubicles
- Telephone Box



METAL ACCESSORIES

- Switch Boxes
- Junction Boxes



CABLES & WIRES

Building Wires

- American Standards (UL) Wires
- British Standards (BS) Wires
- International Electro-technical Commission Standards (IEC) Wires
- Low Smoke, Halogen Free Wires



Overhead conductors

- Bare Stranded Soft Drawn Copper Conductors (SDC)
- Bare Stranded Hard Drawn Copper Conductors (HDC)
- All Aluminum Conductors (AAC)
- All Aluminum Alloy Conductors (AAAC)
- Aluminum Conductors, Steel Reinforced (ACSR)
- Aluminum Conductors, Aluminum-Clad Steel Reinforced (ACSR / AW)
- Aluminum Conductors, Aluminum-Alloy Reinforced (ACAR)
- Weather Resistant XLPE Insulated Service Drop Cables



Power Cables

- Low Voltage Power & Control Cables
- Medium Voltage Power Cables
- High Voltage Power Cables
- Low Smoke, Halogen Free Cables
- Cables for Special Applications





Signal, Communication & Data Cables

- Telephone Cables
- Coaxial Cables (RG6 / U)
- Local Area Network Cables (LAN)



LIGHTING

-  Halogen
-  Fluorescent
-  Energy Saving



WIRING ACCESSORIES (SWITCH & SOCKET)

-  Farah
-  Omnia
-  alf
-  Mira
-  Sidra



COMMUNICATION SYSTEMS

-  Audio Intercom



Contact Us



alfanar markets and sells over 800 electrical construction products in the Saudi Arabian markets and exports them to several countries in the Middle East, Europe, Asia and Africa.

Through our several operational domains and a widespread network of distributors, we ensure uninterrupted supply of **alfanar** products. We also provide solutions to our clients including end-users, project owners, engineering contractors and consultants.

alfanar's highly-qualified engineers, sales & marketing teams not only cater to its customers' requirements

Scan the QR code
and contact us

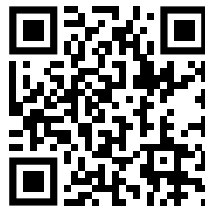



Code# 18681 for MKT_MVPC_2022