

INSTALLATION

& OPERATION MANUAL

DISTRIBUTION TRANSFORMERS

OIL IMMERSED up to 6 MVA



النفار
alfanar

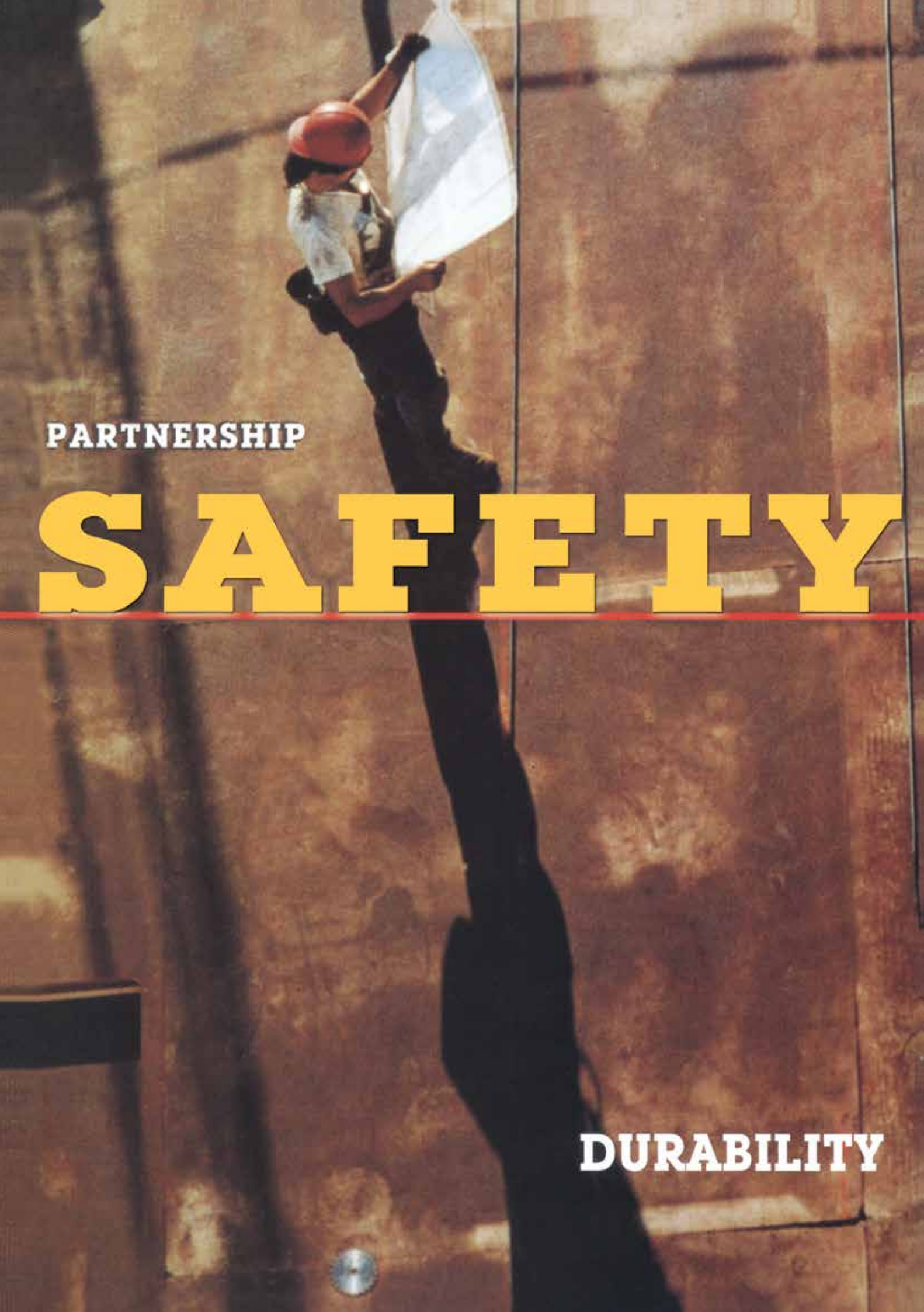

PARTNERSHIP

SAFETY

DURABILITY

CONTENTS

1. General	4
1.1. Information concerning this manual	5
1.2. Safety information symbols	5
1.3. Transportation	6
1.3.1. Transportation by truck	6
1.3.2. Handling	7
1.3.3. Acceptance procedure	7
1.4. Storage of transformers	7
1.4.1. Preparation and checking of transformers before storage	7
1.4.2. Monitoring and checking of transformers during storage	7
1.4.3. Storage after transformers are taken out of operation	7
2. Installation and Connection	8
2.1. Installation	9
2.2. Connections	12
2.3. Earthing	17
3. Putting into Service	18
3.1. External check	19
3.2. Electrical measurements	19
3.3. Energizing	20
3.4. Operation data	21
3.4.1. Ambient temperature and temperature rise	21
3.4.2. Short circuit impedance - voltage drop and short circuit protection /short circuit time	22
3.4.3. Losses and efficiency	23
3.4.4. Tolerances	23
3.4.5. Vector groups – load ability of low voltage neutral	24
3.5. Parallel operation	24
3.6. Overloading	26
4. Rating Plate	28
5. Maintenance	30
5.1. External check (six months)	31
5.2. Yearly maintenance	31
6. Liquid sampling and analysis	32
7. Accessories	34
8. Standard	40
Notes	42

GENERAL

A detailed technical drawing of a high-voltage electrical assembly, possibly a transformer or a high-voltage switchgear. The drawing is a perspective view showing various components including insulators, bushings, and structural frames. The components are rendered in a light gray color against a dark gray background. The drawing is a line drawing, showing the outlines and details of the parts. The word "GENERAL" is written in large, bold, white capital letters in the upper left corner. A large white number "1" is positioned in the lower left corner.

1

1 - GENERAL

1.1 Information concerning this manual

This manual contains important information on transformer equipment, handling, operation etc. Full compliance with the safety and service instructions given herein are important conditions for safe and smooth operations. Additionally, all applicable local safety and accident-prevention instructions and regulations should be taken into consideration in conjunction with this manual.

All persons involved must carefully read this manual before starting any work and/or operation of the equipment. This manual is an integral element of the product. It must be stored close at hand and must be available to all personnel at all times. In an attempt to make things clearer and easier to understand, pictures contained in this manual may have been magnified, or they may not show exactly what you see on your specific equipment.

The documentation accompanying this equipment may contain further instructions, manuals etc. by OEMs of components integrated with this equipment. Be sure to comply with this information (especially safety and security information), in addition to all the information contained herein.

1.2 Safety information symbols

This manual uses symbols to highlight information concerning health, safety and security. Such information always starts with an eye-catching title like “Danger”, “Warning” or “Caution”, indicating the degree to which life, limb or property are at risk.

Such information must be absolutely complied with. Use common sense and caution to avoid accidents and damage to persons and property.



DANGER

Indicates a dangerous situation that is imminent and direct and will cause the death of people or severe injuries unless properly avoided.



WARNING!

Indicates a situation that may become dangerous and cause the death of people or severe Injuries unless properly avoided.



CAUTION!

Indicates a situation that may become critical and cause damage to property unless properly avoided.

Recommendations



NOTE

Highlights tips, tricks and useful information to help you operate your equipment trouble-free and efficiently.



Danger to life caused by electric voltage!

Indicates life-threatening situations caused by hazardous voltages. There is a danger of serious injury or death if the safety notes are not complied with. The work to be performed must only be carried out by qualified electricians.



CAUTION!

Important information. Failure to comply may lead to material damage due to incorrect current and/or voltage.

1 - GENERAL

1.3 Transportation

Distribution transformers are shipped 'ready for installation', which means they are filled with the insulating liquid and with accessories fitted.

1.3.1. Transportation by truck

The transformers must be tightly secured at the top and bottom on the truck. The bottom UPN base will be provided by timber fixed by hex-bolt to avoid movement. After that, the transformer should be secured using straps, making sure they do not pull on the fins or fin reinforcements.

1.3.2. Handling

For loading/unloading the transformer, lifting lugs are provided in the transformer top cover/side wall. The lifting chain or cable angles should not be over 30 degrees from the vertical. Otherwise, spreaders should be used to hold the lifting cables apart to avoid bending of the structure. Transformers are usually stabilized during transit by heavy timber bearers fixed to the vehicle bed. It is therefore essential to remove these bearers before lifting the transformer unit off the vehicle.

Hydraulic jacks should only be used on the provided jacking points, and in such a way that twisting forces on the transformer tank are avoided.

Handling using a forklift truck

Forks must only lift the chassis from within the inverted channel sections, with idler rollers removed.

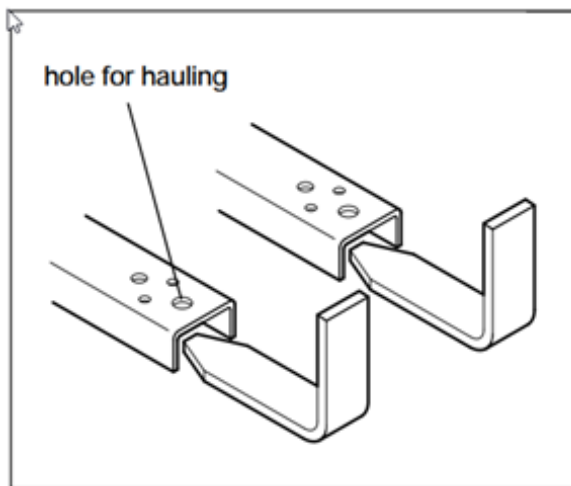

Figure 1 Handling by forklift truck

Lifting by means of slings or a lifting beam

The unit must be handled using the 2 lifting rings located on the transformer cover.

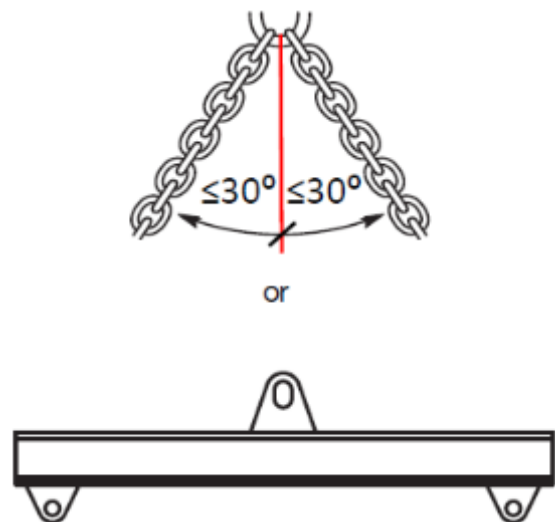

Figure 2 Lifting transformer



NOTE! Never lift a transformer under the cooler fins. Never use the bushings (high voltage (HV) or low voltage (LV) insulators) to guide the transformer when moving it. Nor should the fins or fin reinforcements (round bar on top and bottom of the fins) be pulled on. The securing lugs are not to be used to manipulate the transformer; they must be used exclusively to secure the transformer during transport.

1.3.3 Acceptance procedure

The following points should be checked when the transformer arrives to the site and its accessories should be closely inspected:

- Are there leaks?
- If the liquid level is visible, is it high enough?
- Are there cracks in the bushings?
- Is there rust or is the paint on the transformer or its accessories damaged?
- Are the transformer tanks or accessories damaged?
- Is the delivery complete? Check the number of transformers; check that all accessories are fitted or present.
- Check the information on the rating plate

Transformer shipments are normally insured. In case of damage to the transformer during transport:

- Contact the insurance company concerned and **alfanar**, KSA
- Make a detailed report of the damage immediately
- Repair any paint damage immediately

1.4. Storage of transformers

1.4.1. Preparation and checking of transformers before storage

- When storage of the transformer is required, it is permissible to store the transformer for two years provided that it has the correct oil level.
- Store in a clean, dry location, on a solid foundation, where there is no possibility of mechanical damage.
- The oil conservator and dehydrating breather must be checked to ensure that dry air is being breathed.
- After the storage, perform a Megger test between insulated windings, and from the windings to earth.
- Any damage to the paint should be touched up. Contact **alfanar** Transformer, KSA for the correct procedure.

1.4.2. Monitoring and checking of transformers during storage

Preferably, only fully assembled, liquid-filled transformers should be stored for a long period of time. The following checks must be carried out during the storage period:

- Check the status of the silica gel (its colour indicates whether it is dry or wet)
- Check the level of the oil lock
- Check the transformer for leaks
- Check that there is no damage to the paint and that there is no rust

If any defects are detected, they should either be remedied immediately or **alfanar** should be informed as quickly as possible.

1.4.3. Storage after transformers are taken out of operation

Before the transformer is stored, a full check as described in the 'Acceptance procedure' paragraph should take place. Responsibility for correct storage lies with the customer. Close attention should be paid to the following:

- The possibility for the liquid to expand must be guaranteed
- Contact of the liquid with the air must be avoided
- The transformer must always be stored filled with liquid

INSTALLATION & CONNECTION

A detailed technical line drawing of a power transformer assembly, shown in an isometric perspective. The drawing illustrates the internal and external components, including the core, windings, cooling fins, and various electrical connections. The entire image is rendered in a light gray tone against a dark gray background.

2

2 – INSTALLATION & CONNECTION

2.1 Installation



Ensure that machine characteristics shown on the rating plate correspond with installation conditions: primary voltage(s), tapping links. This plate may be moved and attached to any side of the tank so that it is visible once the machine is in position.

Our transformers may be installed either indoors or outdoors at altitudes up to 1000m. When transformers are installed in a closed cell some rules should be observed as described below.



When the transformers shall be installed in altitudes above 1000m larger clearances between high voltage bushings are needed and the loading must be limited.

Ventilation of transformer kiosks or rooms

If transformers with natural cooling ONAN are installed indoors (in kiosks or rooms) sufficient large ventilation openings are needed underneath and above the transformer and preferably on opposite sides of the room or kiosk to allow for the flow of a sufficient amount of cooling air. This cooling air ensures that the heat generated by the transformer losses are released from the kiosk or room and that the air streams along the transformer from bottom to top.

The airflow depends on:

- The size of the cooling openings
- The difference in height of the air entrance and outlet openings
- The resistance for the airflow, such as louvers, filters, pipes or ducts
- **Calculation of height and cross-sectional area of ventilation wall opening (figure 3).**

In case of natural cooling (AN), the purpose of the plant room ventilation system is to disperse the heat, resulting from the total heat losses generated by the operating transformer, by natural convection.

An efficient ventilation system comprises a fresh air inlet wall opening of cross-sectional area A_i positioned low down in the room, and air outlet opening of cross-sectional area A_o positioned high up on the opposite wall of the room at a height H above the air inlet opening.



NOTE: With regard to sufficient ventilation it is recommended that the minimum distance from walls is 30 cm, and between transformers 60 cm, if not higher. Safety regulations may require different ventilation distances depending on the type of connection and installation of cables and bus – systems or inspection and maintenance requirements.

2 – INSTALLATION AND CONNECTION

Reference Design calculation:

P_{total}	sum of losses under no load and losses due to load on transformer, expressed in kW at 75°C, plus losses generated by any other unit in the same room.
A_i	cross-sectional area of fresh air inlet wall opening (deduct possible area obstructed by grill), expressed in m ² .
A_o	cross-sectional area of air outlet wall opening (deduct possible area obstructed by grill), expressed in m ² .
H	difference in height between inlet and outlet wall opening centre-lines, expressed in m.

$$A_i = \frac{0.182P_{total}}{\sqrt{H}}$$

$$A_o = 1.1 \times A_i$$

This formula is valid for an average annual ambient temperature of 20°C and at a maximum altitude of 1000 meters.

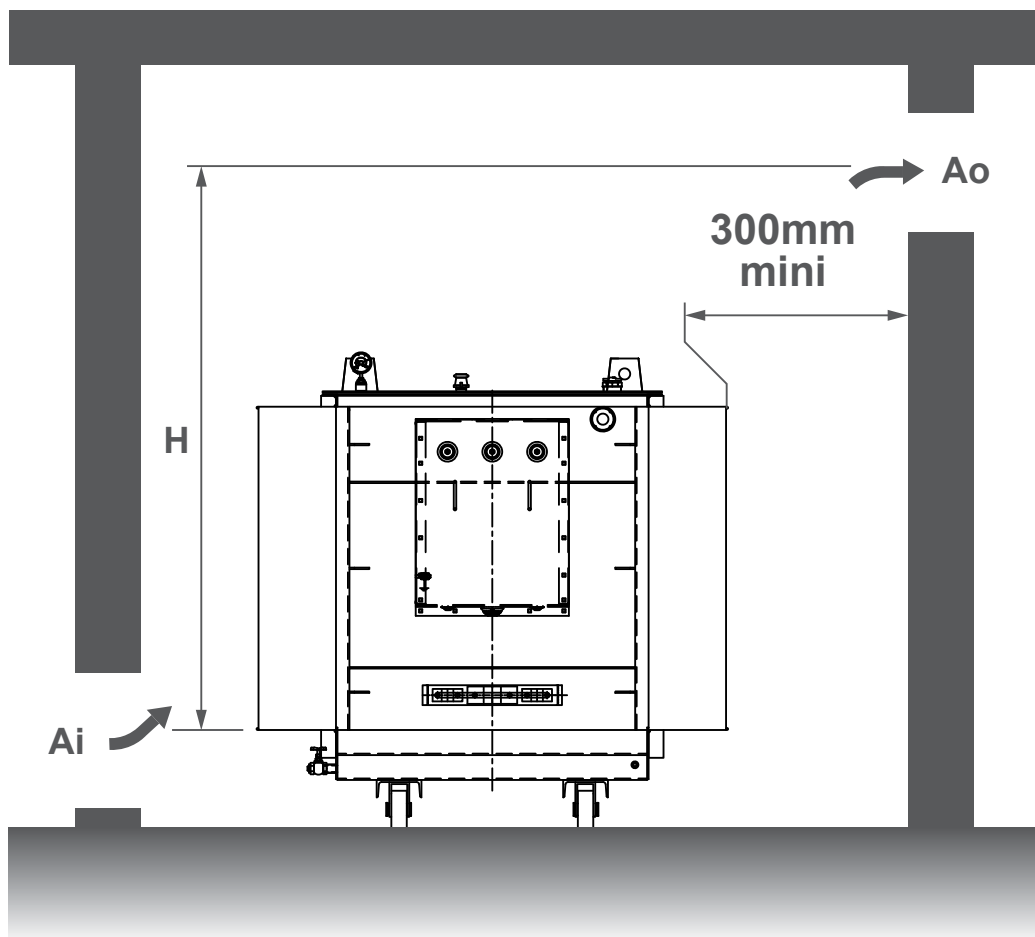

Figure 3

- Calculation of forced ventilation of plant room (figure 4)



A ventilation system of this type is required for a cramped or poorly ventilated plant room, or for a room in which the ambient temperature is much higher than the temperature outside, in view of the ambient temperatures used for designing the transformer.

Should the transformer be frequently overloaded, a forced ventilation system can help to disperse the heat generated by the unit, although it will not reduce the adverse effects of such overloading on the equipment's life.

An air extract fan discharging outside the plant room may be fitted to the outlet wall opening, located at high level, in order to increase natural convection in the room; this fan can be thermostat-controlled.

Recommended discharge rate (m^3/s) at 20°C = $0.11 P_{\text{total}}$.

P_{total} = total heat losses to be dispersed, expressed in kW, for all equipment installed

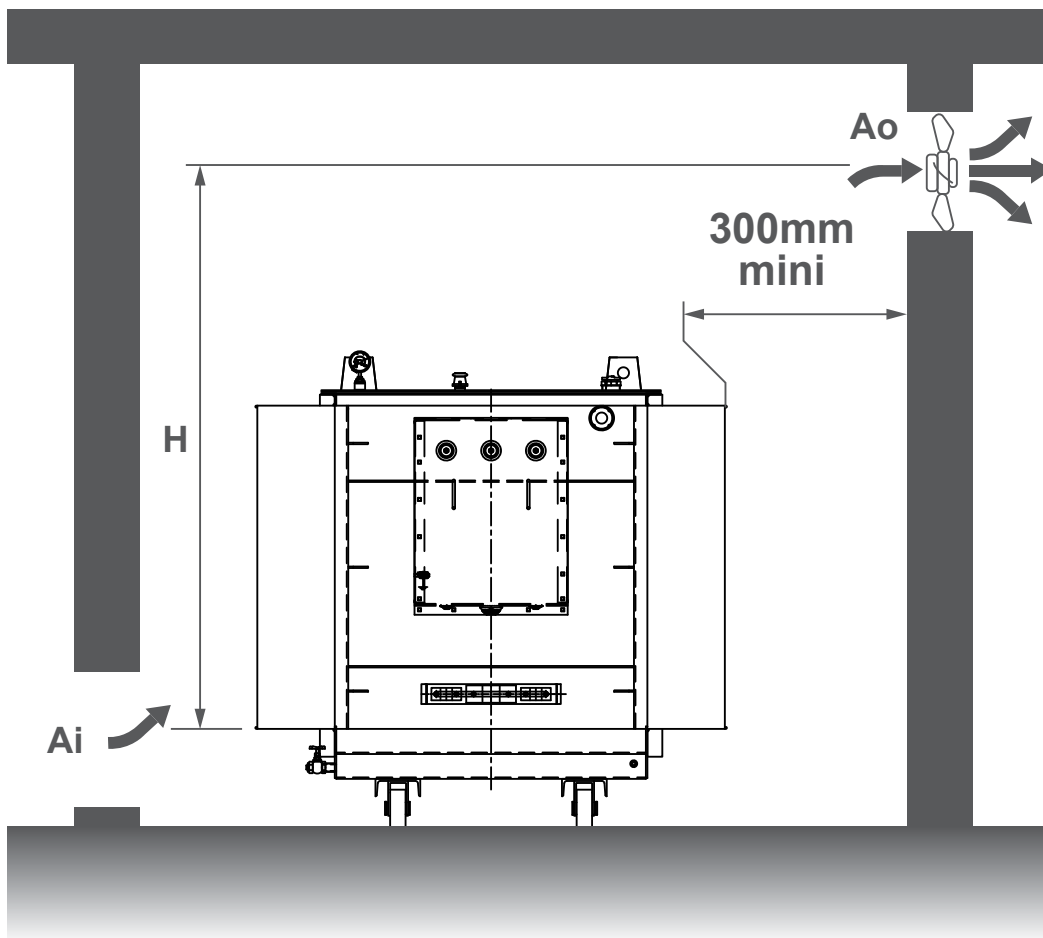

Figure 4

2 – INSTALLATION AND CONNECTION

2.2 Connections

- **Electrical and other connections**



Always ensure that connection of the cables and busbars to the bushings is done without any tensile force being exerted on the bushings that can lead to leakage by the gasket or cracks in the bushings.

A flexible connection is highly recommended in all cases. In this way, expansion of the conductors due to temperature differences cannot lead to leaks or cracks.

Transformer bushings connect the network cables to the primary and secondary windings, Through the metallic cover while electrically isolating them. Bushings are chosen depending on the voltage, current and applications.



Description	Max	Max
	Voltage (kV)	Current (A)
DT 1/250	1	250
DT 1/630	1	630
DT 1/1000	1	1000
DT 1 / 2000	1	2000
DT 1/3150	1	3150
DT 3/250	3	250

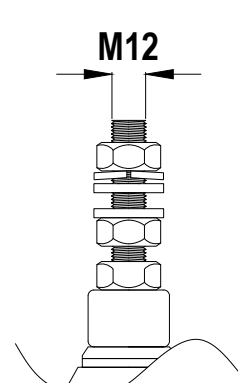

DT 1/250	Max Voltage (kV)	Max Current (A)
	1	250

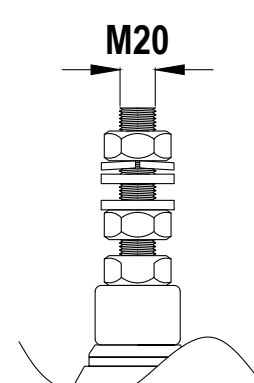

DT 1/630	Max Voltage (kV)	Max Current (A)
	1	630

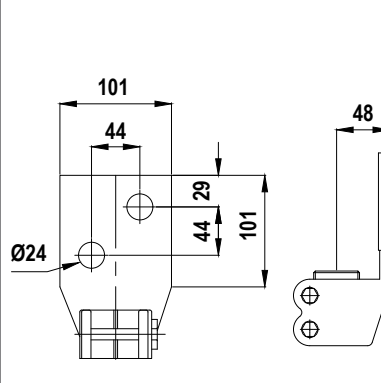

DT 1/1000	Max Voltage (kV)	Max Current (A)
	1	1000

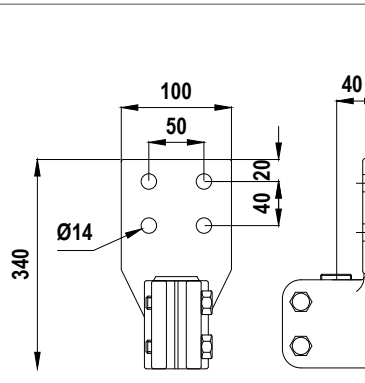

DT 1 / 2000	Max Voltage (kV)	Max Current (A)
	1	2000

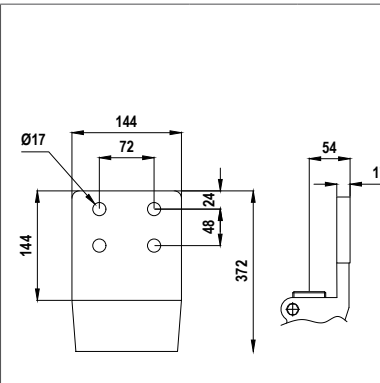

DT 1/3150	Max Voltage (kV)	Max Current (A)
	1	3150

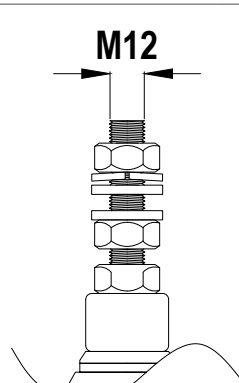

DT 3/250	Max Voltage (kV)	Max Current (A)
	3	250

2 - INSTALLATION AND CONNECTION

afanar Standard Bushing

Description	Max	Max
	Voltage (kV)	Current (A)
DT 3/630	3	630
Bar 3.6/850	3	850
Bar 3.6/1600	3	1600
Bar 3.6/2500	3	2500
DT 3/4500	3	4500
DT 3/6300	3	6300

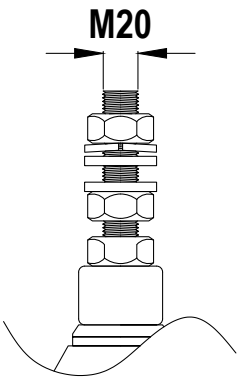
		
DT 3/630	Max Voltage (kV)	Max Current (A)
	3	630

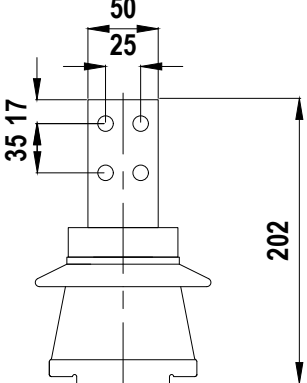
		
Bar 3.6/850	Max Voltage (kV)	Max Current (A)
	3	850

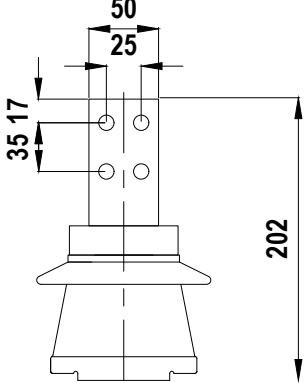
		
Bar 3.6/1600	Max Voltage (kV)	Max Current (A)
	3	1600

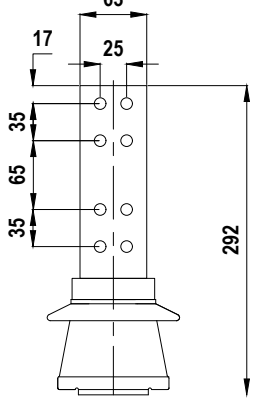
		
Bar 3.6/2500	Max Voltage (kV)	Max Current (A)
	3	2500

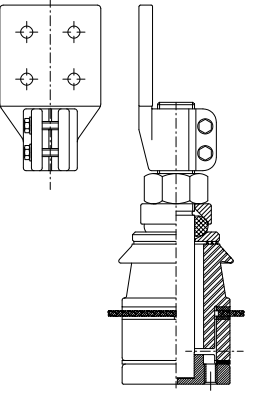
		
DT 3/4500	Max Voltage (kV)	Max Current (A)
	3	4500

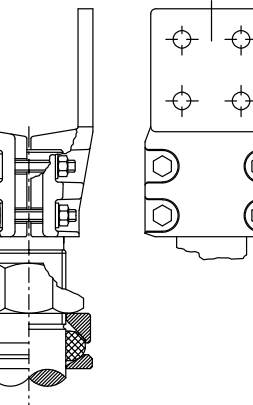
		
DT 3/6300	Max Voltage (kV)	Max Current (A)
	3	6300

Bushing St.1 Suitable for Low Voltage Side

Torque values to be used: see table 1

Description	Max	Max
	Voltage (kV)	Current (A)
Monoblock 1.1/800	1	800
Monoblock 1.1/1700	1	1700
Monoblock 1.1/2500	1	2500
Monoblock 1.1/4000	1	4000

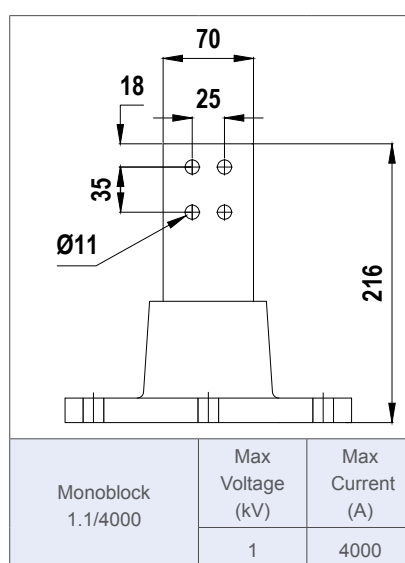
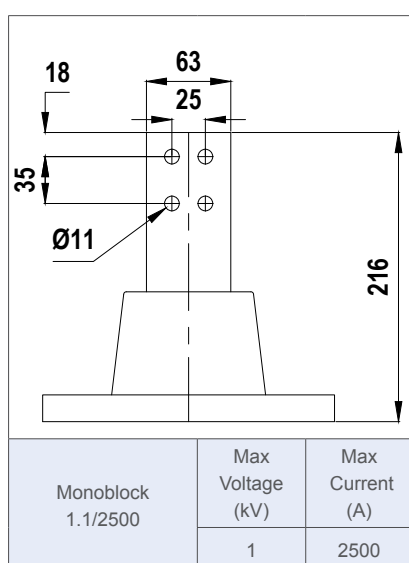
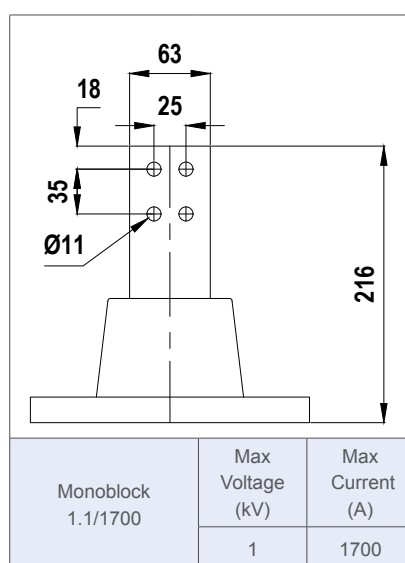
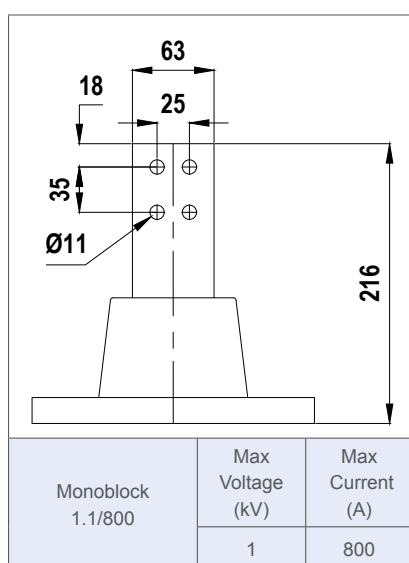

2 - INSTALLATION AND CONNECTION

alfanar Standard Bushing

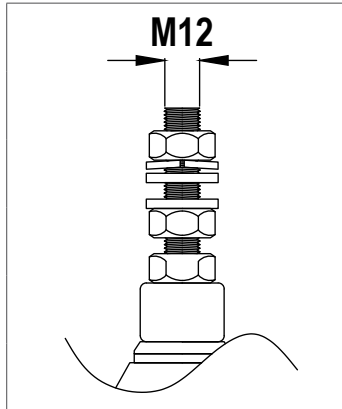

DIN Type Bushing			
Description	Max Voltage (kV)	Max Current (A)	Creepage
DT 20 NF/250 (440)	20	250	440
DT 30 NF/250(600)	30	250	600
30 / 250 - (1320)	30	250	1320
30 / 250 - (1650)	30	250	1650

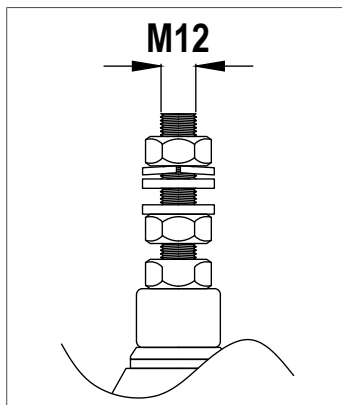

Heat Shrinkable Bushing			
Description	Max Voltage (kV)	Max Current (A)	Creepage
SH-17.5KV /250A-NI	17.5	250	170
SH-36 KV /250A	36	250	450

Shrinkable Material NOT in **alfanar** Scope of Supply

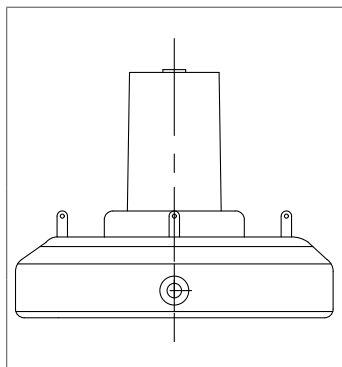

Plugin Bushing *			
Description	Max Voltage (kV)	Max Current (A)	Creepage
PL 24/250	24	250	N.A.

Suitable Elbow Connector NOT in **alfanar** Scope of Supply
MAX. Cable Size 120 mm.

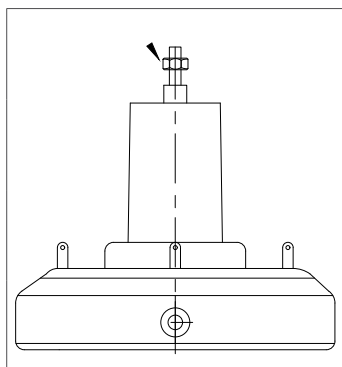

Plugin Bushing *			
Description	Max Voltage (kV)	Max Current (A)	Creepage
PL 36/630	36	630	N.A.

Suitable Elbow Connector NOT in **alfanar** Scope of Supply
MAX. Cable Size 240 mm.

Bushing St.2 Suitable for High Voltage Side

* For plugin bushing, suitable elbow connector to be used for cable connection.

Torque values to be used: see table 1



Ensure that all connections have large, solid and clean contact surfaces. When connecting different materials, precautions should be taken to avoid electrolytic couples. These connections can be made using cable lugs, flat busbars or adapted clamps. Each feeder conductor must have a sufficiently large section.



Whenever the transformer's HV and LV porcelain bushings are worked on, it must be ensured that the lower nut on the bushing remains in position. This ensures that the transformer remains sealed. Use 2 spanners when tightening the other nuts on the bushing to prevent the bushing from twisting.

Table 1: Tightening Torque Values

Bolts	Class 6.8 anticorrosion treated steel	Class A2-70 and A4-70 stainless steel	Class A2-80 and A4-80 stainless steel	Brass
M8	15.2	15.5	17.7	7.6
M10	30	30	35	15.1
M12	52	53	60	25
M14	83	85	97	41
M16	130	133	152	55

Tightening torque given in N.m.

Tightening tolerance $\pm 20\%$.

The above torque values are for assemblies incorporating plain washers.

However, we recommend the incorporation of contact washers behind the plain washers; the above torque values should be increased by 35% if this is done.

Steel and stainless steel bolts shall be greased prior to fitting.

2.3. Earthing



The transformer tank must be connected to the HV earthing system.

Earthing bolts or bosses are fixed onto the cover, the roller carriage or the base of the transformer tank. The electrical resistance of the earthing terminal is usually specified by the power supply company. Ensure that the connection point is kept clean.

PUTTING INTO SERVICE

A detailed technical line drawing of a high-voltage electrical switchgear assembly. The drawing shows a complex arrangement of components including insulators, busbars, and a central mechanism. The perspective is from an elevated angle, looking down into the structure. The drawing is rendered in a light gray color against a dark gray background.

3

3 – PUTTING INTO SERVICE

3.1 External check

Before putting a transformer into service the following shall be observed:

- Check that the name-plate data are in accordance with plans, circuit-diagrams etc. It is particularly important to check that the voltages of the primary side and the secondary side fits the voltages of the high voltage and low voltage network.
- Check that the transformer data fits the data of other transformers for parallel operation, if applicable.
- If necessary, adjust the tap changer for voltage regulation to the suitable tapping in off-circuit condition
- Check the oil level in the conservator, if necessary top up dry transformer oil of appropriate quality at the filling plug of the conservator.
- Check that the ventilation for cooling air is sufficient and ventilation openings are free and clean in the case of an indoor installation.
- Check that the transformer is securely fastened down to prevent movement during operation.
- The transformer shall be clean, especially bushings and busbars shall be cleaned and dust removed.
- Check that the transformer has no leaks.
- Check that protection devices like the Buchholz relay and thermometer are working and connected. The thermometer pocket shall be filled with transformer oil to 2/3 of its capacity.
- Check that the silica gel has the colour of dry condition. If the colour has changed, the silica gel shall be exchanged or dried at 140 °C.
- Check that the transformers are grounded with the correct grounding wire size.
- Check that all terminal connections are in good order, metallic bright and well tightened. Busbars and cables should have elongation ability for thermal expansion.
- Check all required dielectric clearances.
- Check gaps of arcing horns if provided.
- Check that no voltage difference exists between points to be connected prior to connecting the transformer terminals to the network.

3.2 Electrical measurements

- Check the insulation resistance between windings and tank by using the Megger test.
- Conduct a continuity test of the connections and windings.
- Check the auxiliary devices and accessories (correct operation, setting and checking of the contacts, cabling, checking of test equipment).
- If the transformer has been stored for more than a year, check the dielectric strength of the insulation oil. The break down strength shall be at least 40 kV/2.5 mm.

3 – PUTTING INTO SERVICE

3.3. Energizing



Energizing should be carried out by an authorized person and the locally applicable safety instructions should be observed.

Conditions for Energizing

The transformer should be initially energized without load and with the tap changer in the position equivalent to the rated no-load voltage. Measure the voltages between the LV phases themselves and to the earth.



For safety reasons we strongly advise against measuring directly on the LV transformer terminals. If these voltages deviate from the rated no-load voltage, it can be adjusted (see procedure below). The transformer is left with no load for a few hours. During this period the sound, temperature and liquid levels – if visible – are checked regularly.



The transformer may now run under load. A gradually increasing load with intermediate checks is recommended.

Adjusting the low voltage

If the voltage on the LV side both at no load and under load deviates from the rated value and this must be adjusted, the procedure is as follows:

- De-energize the transformer at the HV and LV side and earth it properly;
- Unlock the tap changer by lifting the knob;
- Change the tap changer to the desired position;
- Release the knob until the spring presses it down again and thus re-locks the tap changer.

Low voltage too high (must be decreased)



If the applied high voltage is higher than the rated transformer high voltage, this results in the low voltage being too high.

In this case the HV tap changer knob should be put in a position that corresponds to a high voltage that is higher than the rated high voltage (see rating plate). The tap changer must be set at a lower position number.

Low voltage too low (must be increased)

If the applied high voltage is lower than the rated transformer high voltage this results in the low voltage being too low.

In this case the HV tap changer knob should be put in a position that corresponds to a high voltage that is lower than the rated high voltage (see rating plate). The tap changer must be set at a higher position number.

Increasing low voltage (higher tap changer knob position number compared with reference value)

Decreasing low voltage (lower tap changer knob position number compared with reference value)

Example (see rating plate)

	Position no. tap changer	HV Volt	LV Volt	
Rated. pos.	1	14490	400	Rated voltage
	2	14145		
	3	13800		
	4	13455		
	5	13110		

3.4. Operation Data

3.4.1. Ambient Temperature and Temperature Rise

The transformers are designed for the following ambient temperatures of cooling air:

Design ambient temperatures	30°C
Design-Values: Temperature rise of top oil	50°C
Temperature rise of windings	55°C

*Measured by the change of ohmic resistance



The transformers can also be operated at higher ambient temperatures. It is recommendable to reduce the load if the ambient temperatures are higher than mentioned above. Detailed information can be provided on request.

For more severe ambient conditions **alfanar**, Transformers can offer optional designs with lower temperature rise than mentioned above.

3 – PUTTING INTO SERVICE

3.4.2. Short Circuit Impedance – Voltage Drop and Short Circuit Protection // Short Circuit Time.

The short – circuit impedance of a transformer should not be too high in order to limit the voltage drop of the transformer, that means the difference between the rated voltages at no – load and the voltage in load condition.

The short – circuit impedance should also not be too low in order to limit the short – circuit currents flowing through the transformer to reasonable values. That means the transformer works through its short – circuit impedance also as a short –circuit protection for the whole electrical system being connected to it.

The short – circuit current has electrical, mechanical and thermal impacts on the transformer itself and on the other equipment connected with the transformer like breakers, cables, bus bars



The short – circuit impedance of our transformers as indicated in the catalogue tables are feasible values based on experience and complying with the IEC standard.

These impacts depend on the value of the short – circuit current and on the time until the short circuit is interrupted by protection devices like fuses or breakers.

The max permissible short – circuit time is fixed in IEC to be 2 seconds. Our transformers of 500 kVA and below have a permissible max short – circuit duration of 2 seconds including the power ratings of 800 kVA and above are 3 seconds.

These values of include a rather high safety margin because in practice fuses and breakers interrupt the current in much shorter time being only in the range of milliseconds, that means a very small fraction of the values 2 or 3 seconds.

The short circuit impedance of **alfanar**' s transformers as indicated in the catalogue tables are feasible values based on experience and complying with the IEC standard.

3.4.3. Losses and Efficiency.



The losses have an impact on the total operation cost of a transformer, because of the consumed energy within the transformer.

This should be considered when comparing tenders by an evaluation of the loss – figures taking mainly into account the cost of electrical energy per kWh, the expected life – time or operation – time, the interest – rate for investments and the expected average loading of the transformer.

The cost of losses during the life – time of a transformer is considerably high compared to the transformer cost. Because of this **alfanar** Transformers can offer options with reduced losses. The no – load losses are independent of the load, but the load losses are proportional to the square of the load current.

The efficiency is the ratio between output of active power and the input of active power expressed in %. This means the efficiency of a transformer varies with the load and depends on the power factor of the load.

The efficiency – curve, as a function of the load, has a maximum and drops towards full – load and no load conditions. The load for which the maximum of the efficiency is reached depends on the ratio between no load losses and load losses.

Normally the max value of efficiency is reached at loads between 40 and 50%. This is feasible because the average loading of transformers over a year is quite commonly in this range or even lower. That means in this case over the year the consumption of energy within the transformer will become a minimum. In general, it is much clearer to compare and evaluate the losses itself instead of the efficiency.

3.4.4. Tolerances

Tolerance values for some technical data of transformers are stipulated in the IEC –Standard

Tolerance of voltage ratio at no load $\pm 0.5\%$ or 10% of short – circuit impedance voltage provided this is less than 0.5%

Tolerance of short-circuit impedance voltage on principal tapping $\pm 10\%$

Tolerance of guaranteed total losses $+ 10\%$

Tolerance of each loss component (no load losses and load losses) $+ 15\%$

Provided tolerance of total losses not exceeded.

3 – PUTTING INTO SERVICE

3.4.5. Vector Groups – Load ability of Low Voltage Neutral



The most frequently used vector groups and their respective connection diagrams are detailed in IEC 60076.

The standard for our transformers is vector group Dyn11 and as an option Dyn5. For both, the low voltage neutral is brought out by a separate bushing, which is loadable to 100% current.

3.5 Parallel operation



When running in parallel, the transformers must satisfy the relevant regulations and conditions (including IEC 60076-1 and IEC 60076-8, see Chapter 4).

These are the following:

- Transformers must have the same clock-hour number. The winding connections may be different.
- Impedance voltages must be the same (a tolerance of maximum 10% is allowed)
- Rated voltages must be equal (both HV and LV)
- When continuously running in parallel, the power rating ratio must not exceed 3:1



The information for the above conditions can be found on the rating plate.

Before switching to parallel operation, the following procedure must be followed:

- Connect the corresponding HV terminals
- Connect the corresponding LV terminals
- Provide a (preferably common) earthing on both transformer tanks
- Connect the LV neutrals
- Connect the transformers to the supply system at the HV side. The LV main switches must remain open.
- Check for any difference in voltage between the corresponding LV phases. The voltmeter should show no readings. If however, there is a difference in voltage, the cause should be traced and remedied.
- If there is no difference in voltage between the corresponding LV terminals, the main lower voltage busbars may be energized at the LV side.
- If the tap changers are put out of their rated positions, make sure that both set HV values correspond (see rating plate).



If the above conditions are not satisfied, circulation currents can occur which can lead to damage to the transformer.



For brief parallel operation (e.g. when switching over) this may be permitted. Consult IEC 60076-8 for more details.

The short – circuit impedance should be the same. Deviations of the short – circuit impedance will result in a reduced loading of the group because the transformer with the lowest short – circuit impedance will reach its full load when the other transformers are only partly loaded.

This effect is more severe when the transformer with the lower short – circuit impedance also has the lower power rating.

This is demonstrated by the following examples. It is assumed that short – circuit impedance deviate not more than the permitted tolerance of $\pm 10\%$ according IEC.

Example 1:

Three transformers shall be connected in parallel

Transformer 1: 100 kVA impedance 3.6%

Transformer 2: 200 kVA impedance 4.0%

Transformer 3: 300 kVA impedance 4.4%

The transformers can be loaded that their common short circuit impedance becomes 3.6% according transformer 1.

Transformer 1: $100 * 3.6/3.6 = 100$ kVA

Transformer 2: $200 * 3.6/4.0 = 180$ kVA

Transformer 3: $300 * 3.6/4.4 = 245.45$ kVA

Total load = $100 + 180 + 245.45 = 525.45$ kVA

With this the transformer with the lowest power rating is fully loaded. If the load would be further increased the transformer having the lowest short circuit impedance would be overloaded, what normally should be avoided.

The sum of rated power is $100 + 200 + 300 = 600$ kVA

The loading factor becomes $525.45/600 = 87.6\%$

3 – PUTTING INTO SERVICE

Example 2:

The loading factor becomes higher if the transformer with the highest power rating has the lower short – circuit impedance

Transformer 1: 100 kVA impedance 4.4%

Transformer 2: 200 kVA impedance 4%

Transformer 3: 300 kVA impedance 3.6%

In this case the group can be loaded as follows

Transformer 1: $100 \times 3.6 / 4.4 = 81.8$ kVA

Transformer 2: $200 \times 3.6 / 4.0 = 180$ kVA

Transformer 3: $300 \times 3.6 / 3.6 = 300$ kVA

The total load becomes: $81.8 + 180 + 300 = 561.8$ kVA

The loading factor will be $561.8 / 600 = 93.6\%$

The examples show, that the short-circuit impedance of transformers working in parallel must not be exactly the same, but that certain differences can be accepted and still the result will be acceptable under economic aspects.



Transformers connected in parallel must work on the same tap voltages. Otherwise dangerous circulating currents can flow which are added to the load – current of the transformer having the higher secondary voltage.

3.6. Overloading (Table 2)

According to “Loading Guide for Oil – Immersed Transformers” IEC 60076-7.

The guide indicates how oil – immersed transformers complying with IEC 76 may be loaded above rated currents.

Loading with cyclic variations is assumed, the duration of a cycle usually being 24 hours.

A higher than rated load current is applied during a part of the cycle, but for normal cyclic loading from the point of view of thermal age this loading is equivalent to the rated load at normal ambient temperatures .

This is achieved by taking advantage of low ambient temperature or low-load currents during the rest of the load cycle. It should be considered that inside Kiosks and Transformer Rooms the temperature might be higher than outside due to restricted ventilation.

Choice of Power Rating – Emergency Overload

The required power - rating is normally calculated taking into account the apparent power consumption of all equipment, machines, lighting etc and also transient loads like motor – starts and by considering a load –factor which depends on experience for housing, offices, factories different types of installation and equipment.

Not only the power load is considered but also the voltage drop in transformers and cables etc. and the short – circuit currents which on the secondary side of the transformer are mainly limited by the short – circuit impedance of the transformer.

For the choice of the power rating of the transformer among the standard ratings the calculated load mentioned before is most important, but also the expected future growth of the load and the redundancy in case of a failure of the transformer itself or of cables or any other electrical equipment.

That means that 2 or more transformers having a lower rated power could preferably be chosen instead of one transformer having a high power rating being enough for the totally connected load.

In case of emergency the transformer or the transformers not affected by the failure can carry the load by being overloaded for a limited time until other actions becoming effective like reducing the load by switching off not important machines or equipment or by additional power source like a movable diesel – generator – set being connected. By this a total black – out can be avoided in many cases.

For such cases of emergency the transformers might be higher overloaded than with normal cyclic load and allowing a higher thermal age rate than normal. The emergency overload in any case should not exceed 150%.

Table 2: Overloading

Load percent of rating (%)	Minimum duration in minutes at ambient temperature of	
	30 °C	40 °C
133	240	155
150	98	65



It must be considered that inside kiosks or transformer - rooms the temperature normally is higher than the outside temperature.

RATING PLATE

A detailed technical drawing of a transformer's rating plate assembly. The drawing shows a rectangular metal plate mounted on top of a transformer core. The core is composed of multiple layers of laminated steel sheets. On the top surface of the core, there are several vertical supports or bushings. The rating plate is secured to the core with several screws. The drawing is a perspective view, showing the top and side of the assembly. The background is a light gray, and the drawing lines are in a darker gray.

4

4 - RATING PLATE

Following Data available in the Rating Plate

- 1 Year of manufacture.
- 2 AES serial No.
- 3 Owner serial No for IEC transformer, Item NO. for SEC transformer
- 4 Sap code No.
- 5 Sales order No.
- 6 Rating (kVA).
- 7 Specification "IEC 60076".
- 8 Frequency "Hz".
- 9 High voltage volts @ No-Load "Volts".
- 10 Low voltage volts @ No-Load "Volts".
- 11 Line high voltage current Amp.
- 12 Line low voltage current Amp.
- 13 No of phases.
- 14 Vector group.
- 15 Impedance "%".
- 16 High voltage resistance " Ω " @ 75 °C.
- 17 Low voltage resistance " Ω " @ 75 °C.
- 18 Type of cooling.
- 19 Maximum ambient temperature.
- 20 Maximum top Oil temperature rise °C ".
- 21 Maximum Average winding temperature rise °C ".
- 22 Weight of core and winding "KG".
- 23 Volume of Oil "Liters ".
- 24 Total weight "KG".
- 25 Insulation level lightning impulse "LI" kV.
- 26 Insulation level separate source AC withstand voltage "AC" kV
- 27 Purchase order No.
- 28 SEC Stock No for SEC transformer.
- 29 SEC standard for SEC transformer.

Rating Plate **alfanar** Specification In Accordance With IEC

Rating Plate SEC Specification "51-SDMS-02"





3-PHASE OIL IMMERSERD TRANSFORMER SA 1

YEAR OF MFG	201	OWNER SERIAL NO.	
AES SERIAL NO.		SAP CODE NO.	
		SALES ORDER NO	

KVA	3000	IMPEDANCE	%	
SPECIFICATION	IEC 60076	VECTOR GROUP		Dyn11
FREQUENCY	60	TYPE OF COOLING		ONAN
VOLTS AT NO LOAD	HV 13800	CORE & WDGs	KG	1880
	LV 400	TOTAL WEIGHT	KG	3000
CURRENT IN AMP	HV 41.8	OIL	Utres	743
	LV 1443.4	RESISTANCE (R) AT 75°C	HV	
PHASES	Three		LV	
MAX AMBIENT TEM °C	50	MAX TEMP RISE IN OIL/WDG °C		50 50

INSULATION LEVEL (LI/AC) 95 / 38 KV

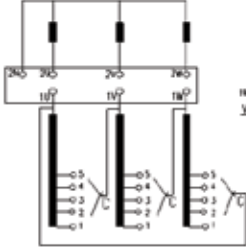
PURCHASE ORDER NO. _____





POS.	VOLTAGE
1	14490
2	14145
3	13800
4	13455
5	13110

WARNING

1. Off Circuit Tap changer , de-energized before changing taps
2. Please refer O & M manual for operating transformer

MADE IN K.S.A



3-PHASE OIL IMMERSERD TRANSFORMER SA 1

YEAR OF MFG	201	ITEM NO.	8512094
AES SERIAL NO.		SAP CODE NO.	
		SALES ORDER NO	



KVA	3000	IMPEDANCE	%	
SPECIFICATION	IEC 60076	VECTOR GROUP		Dyn11
FREQUENCY	60	TYPE OF COOLING		ONAN
VOLTS AT NO LOAD	HV 13800	CORE & WDGs	KG	1770
	LV 400	TOTAL WEIGHT	KG	2805
CURRENT IN AMP	HV 41.8	OIL	Utres	911
	LV 1443.4	RESISTANCE (R) AT 75°C	HV	
PHASES	Three		LV	
MAX AMBIENT TEM °C	55	MAX TEMP RISE IN OIL/WDG °C		45 50

INSULATION LEVEL (LI/AC) 110 / 38 KV

PURCHASE ORDER NO. _____

SEC STOCK NO. _____

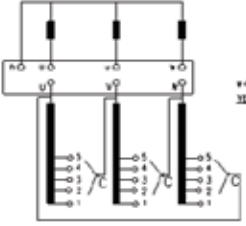
SEC STANDARD. 51-SDMS-02

POS.	VOLTAGE
1	14490
2	14145
3	13800
4	13455
5	13110

WARNING

1. Off Circuit Tap changer , de-energized before changing taps
2. Please refer O & M manual for operating transformer

MADE IN K.S.A

MAINTENANCE

A detailed technical line drawing of a power transformer assembly, shown in an isometric perspective. The drawing includes the top tank with cooling fins, a central bushing assembly with a tap changer, and a lower section showing the internal winding and core structure. The entire image is rendered in a light gray tone against a dark gray background.

5

5 – MAINTENANCE



Hermetically sealed distribution transformers are basically maintenance free, where transformers with an expansion tank require little maintenance.

5.1. Six month external check after energizing

This maintenance check can be carried out while the transformer remains energized.

Attention: keep a safe distance from energized (live) parts.

This type of maintenance comprises the following:

Assessing the various noises coming from the transformer.

- Checking the ambient temperature and ventilation of the premises.
- Checking for leaks, rust and damage.
- Checking for dirt on the bushings, apparatus and control units.
- Checking the colour of the silica gel (if applicable).
- Checking the liquid level via the oil level gauge (if present).
- Checking the liquid temperature (if thermometer present), Checking local temperature rises due to contact resistances on HV and LV connections (infrared temperature measurement, discolorations, etc.).
- Checking if the overpressure relief device has been activated (if present).

5.2. Yearly maintenance

This type of maintenance should be carried out while the transformer is de-energized and earthed at the HV and LV sides. Also don't forget to switch off the auxiliary voltage for accessories.

Yearly maintenance comprises the following:

- Performing the six month external check (see 5.1.).
- Remediating the comments from the yearly external inspection.
- Checking the compound level in the HV cable junction box (if applicable).
- Opening the HV and LV air cable boxes (if applicable), checking for condensation and water penetration.
- Checking the auxiliary devices and accessories (correct operation, setting and checking of the contacts, cabling, checking of test equipment).
- Checking the correct operation of the tap changer. The tap changer is tested whilst the transformer is de-energized by switching the tap changer into various positions and by measuring whether there is continuity in the internal connections.



We advise transformer users to adjust the above maintenance frequency if the transformers are located in severe weather conditions and if the operating conditions allow or require a different frequency.

A detailed technical drawing of a mechanical assembly, possibly a liquid sampling or analysis instrument. The drawing is rendered in a light gray line-art style against a dark gray background. It shows a complex structure with various components, including a large cylindrical base, several vertical supports, and a top section with multiple ports or nozzles. The drawing is a perspective view, showing the depth and three-dimensional nature of the parts.

LIQUID SAMPLING AND ANALYSIS

6

6 – LIQUID SAMPLING AND ANALYSIS

Analysis of a cooling liquid sample helps determine the condition of the transformer liquid and gives an indication of the condition of the windings, (tap changer) switch and internal connections, where various liquid tests and analyses can be performed upon request.



The sampling procedure, described in standards IEC 60475 and IEC 60567, must be followed strictly, where sampling of hermetically sealed transformers in service (= energized) is not recommended.

After a sample of the liquid has been taken, the level must be checked without opening the transformer if possible, and if necessary, or in case of doubt, it must be adjusted by an authorized technician from **alfanar**.



alfanar advises a 5-year liquid analysis for hermetically sealed transformers and a 2-year liquid analysis for transformers with an expansion tank. This can be adjusted if the results obtained indicate the necessity, or if operating conditions allow or require it



Note: Never top up with another type of liquid other than the original type of liquid in the transformer.

ACCESSORIES

A detailed technical line drawing of various electrical accessories, including insulators, terminal blocks, and mounting hardware, arranged in an isometric perspective. The drawing is rendered in a light gray color against a dark gray background.

7

7 - ACCESSORIES

At the customer's request the transformers can be fitted with a large variety of apparatus and control equipment. More information on this (description, operation, ...) can be found on the TR sheets which are available upon request.

Item name	Type/Specs	Drawing No.
Bushings HV	DIN Bushing (20NF/250A (440))/DIN 42531	TR276206
	DIN Bushing (30NF/250A (600))/ DIN 42531	TR276207
	Heat shrinkable Bushing (36 KV /250 A)/IEC 60137	TR276215
LV Bushings	Bar Bushing (3KV/850 A)/ DIN 42539	TR276104
	Bar Bushing (3KV/1600 A)/ DIN 42539	TR276105
	DIN BUSHING 1KV/2000A(75)/ DIN 42530	TR276113
	DIN BUSHING 1KV/3150A(75)/ DIN 42530	TR276114
	DIN BUSHING 3kV/4500A/ DIN 42539	TR276115
	20KV-30A-5 Position (F209353)/IEC60214	TR464321
Off-Load Tap Changer	20KV-60A-5 Position -L=200/IEC60214	TR464326
	20KV-120A-5 Position -L=150/IEC60214	TR464310
	30KV-60A-5 Position -L=200/IEC60214	TR464346
Oil Temperature Indicator:	Top Dial Oil Thermometer 1" or equivalent	TR469710
Oil Temperature Indicator:	Visual Oil Level Indicator or equivalent	TR469504
Pressure Relief Device:	313.2	TR469203
Drain Valve	DRAIN VALVE 1" BALL TYPE or equivalent	TR469103
Roller	BI-DIRECTIONAL ROLLERS Ø125mm	TR469402
	BI-DIRECTIONAL ROLLERS Ø150mm	TR469401
	BI-DIRECTIONAL ROLLERS Ø200mm	TR469406

-Manufacture may change according to the submitted drawing during submittal stage.

7 - ACCESSORIES

- **Pressure Relief Device**

The pressure relief device is used to prevent the rapid buildup of pressure within the transformer tank that might cause an explosion hazard. It is designed to operate and discharge any pressure greater than their set value to the atmosphere.

The valve can also be equipped with a specially manufactured protective cap to prevent unauthorized operation of the valve.



- **Breather type transformer with expansion tank**

The transformer tank is connected by pipework to an expansion tank, mounted above the unit, which ensures that the dielectric fluid level remains sufficiently high in the transformer tank: variations in dielectric fluid volume are absorbed by the expansion tank which remains at atmospheric pressure. This type of unit therefore requires regular maintenance suited to the climatic conditions in the vicinity of the transformer.



- **Buchholz relay**

Fitted to the pipework linking the expansion tank to the transformer tank, this accessory ensures protection against internal faults only, by monitoring dielectric fluid levels and fluctuations.

To ensure proper operation, the Buchholz relay must be completely bled of air.

Faults detected on a live transformer unit may include:

- Dielectric fluid level is detected as low.
The Buchholz relay is partially empty; the top-level float is at the bottom. Reasons for this low fluid level are the same as those given for the protection relay but in the present case, the relay will automatically activate the alarm.
- Major discharge of oil towards the expansion tank is detected.
A violent emission of gas, resulting in serious electrical faults within the transformer tank, leads to a large discharge of oil into the expansion tank, which causes the Buchholz relay bottom float to pivot; the transformer unit must be de-energized immediately and permanently.
Contact **alfanar** after sales service.



- **Tap changer**



Tap changer setting is carried out in the following way:

In order to change the position of the tap changer, pull the control device body along the up direction; turn it to the desired position notch and release. The spring system will automatically lock the position via position stopper and position notch on the body.

Tapping links

Set the tapping point of tap changer to the required position:

Pos. 1: upper primary voltage

Pos. 2: between upper and rated primary voltage

Pos. 3: rated primary voltage

Pos. 4: between lower and rated primary voltage

Pos. 5: lower primary voltage

Adjustments to tapping point must be undertaken with the transformer off-load and de-energized.



- **Cable box**

Cable boxes are enclosures for the transformer terminals. They provide protection from hazardous access to terminals, and protect the terminals from water, dust and mechanical impacts up to different degrees. Protection degrees are described in IEC 60529. The cable box can be either top or side accessible depending on customer requirements.

The degree of protection which **alfanar** offers is IP 54 according to IEC 60529.

7 - ACCESSORIES

- **Oil level indicator**

Transformers can be equipped with an oil level indicator on the conservator, on the cover, or on the side, depending on the design. Magnetic and prismatic types of oil level indicators are available.



- **Thermometer**

The dial type thermometer indicates the maximum highest oil temperature reached during a certain period. Two contacts are optional to provide an electrical signal, the first is for an alarm and the second for tripping.



- **Earthing terminal on tank**

Two earthing points are integrated in each tank, stainless stud, stainless flag with 12mm hole and stainless threaded M10 terminal are the available earthing point types.

- **Draining valve**

The drain valve is used to drain or sample the transformer oil from the transformer tank. These valves are fitted to the transformer tank by welding the pipe of the valve to the tank. These valves are 100% tested to ensure no leakages.



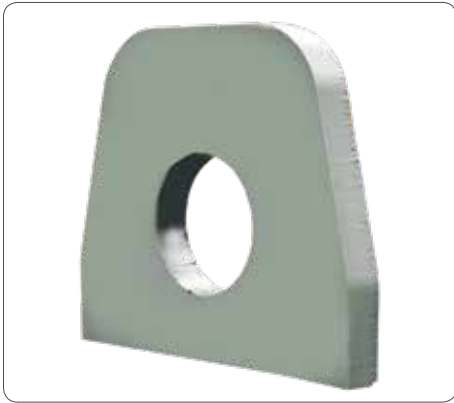

- **Lifting lugs**

Lifting lugs are used for untanking and lifting. 2 lugs are supplied for units weighing up to 3.5 tons, 4 lugs for heavier units.



- **DMCR relay**

A DMCR relay is a multifunctional device. It indicates the temperature and oil level and is equipped with electrical contacts for:

- Gas formation
- Pressure excess
- 2 Temperature levels: alarm and trip



- **Roller**

Bi-directional rollers are used for ground mounted units: diameter 125mm for ratings up to 630 kVA, diameter 150/200 mm for higher ratings.



- **Winding temperature indicator**

This device measures the LV and HV winding temperature. A winding temperature indicator or WTI is also used as protection for the transformer.

STANDARDS

A detailed technical line drawing of a power transformer assembly, shown in an isometric perspective. The drawing illustrates the internal and external components, including the core, windings, cooling system, and various electrical connections. The entire image is rendered in a light gray tone against a dark gray background.

8

8 – STANDARDS

In addition to this manual the IEC and SDMC standards considered as an important and wider source of information about transformers.

SASO	51-SDMS-02	SEC Distribution material specification for Distribution transformer up to 36 kV, 400/231 volts.
	IEC 60076-1	General
	IEC 60076-2	Temperature rise
	IEC 60076-3	Insulation levels, dielectric tests and external clearances in air
	IEC 60076-5	Ability to withstand short-circuit
	IEC 60076-7	Loading guide for oil-immersed power transformers
	IEC 60076-8	Application guide
IEC	IEC 60076-10	Determination of sound levels
	IEC 60616	Terminal & tapping markings for power transformers
	IEC 60296	Specification for unused mineral insulating oils for transformers and switchgear.
	IEC 60422	Supervision and maintenance guide for mineral insulating oils in electrical equipment.
	IEC60475	Method of sampling liquid dielectrics.
	IEC 60567	Guide for the sampling of gases and of oil from oil-filled electrical equipment and for the analysis of free and dissolved gases.
	IEC 60599	Mineral oil-impregnated electrical equipment in service - Guide to the interpretation of dissolved and free gases analysis.



For catalogue soft copy scan QR code